





SELF-REPAIR HINTS

| | | |
|------|--------------------------------|-----|
| [bg] | Съвети за ремонт | 2 |
| [hr] | Savjeti za popravak..... | 23 |
| [cs] | Poznámky k opravě | 44 |
| [da] | Tip til reparation | 65 |
| [nl] | Reparatie informatie..... | 86 |
| [en] | Self-repair hints..... | 107 |
| [et] | Remonditeave..... | 128 |
| [fi] | Korjausvinkit..... | 149 |
| [fr] | Conseils de réparation | 170 |
| [de] | Reparatur Hinweise | 191 |
| [el] | Υποδείξεις επισκευής | 212 |
| [hu] | Javítási útmutató | 233 |
| [it] | Consigli di riparazione..... | 254 |
| [lv] | Informācija par remontu | 275 |
| [lt] | Informacija apie remontą | 296 |
| [no] | Reparasjonstips | 317 |
| [pl] | Wskazówki naprawy | 338 |
| [pt] | Dicas de resolução | 359 |
| [ro] | Indicii pentru reparații..... | 380 |
| [sk] | Poznámky k opravám | 401 |
| [sl] | Nasveti za popravilo..... | 422 |
| [es] | Consejos de reparación..... | 443 |
| [sv] | Reparationsinformation..... | 464 |
| [tr] | Onarım İpuçları | 485 |

Съвети за ремонт - Перална машина

| | |
|--|----------|
|  Относно този документ | 3 |
| 1.1 Важна информация..... | 3 |
| 1.1.1 Цел..... | 3 |
| 1.2 Обяснение на символите..... | 3 |
| 1.2.1 Нива на опасност..... | 3 |
| 1.2.2 Символи за опасност..... | 3 |
| 1.2.3 Структура на предупрежденията..... | 4 |
| 1.2.4 Общи символи..... | 4 |
|  Безопасност | 5 |
| 2.1 Общи инструкции за безопасност..... | 5 |
| 2.1.1 Всички домашни уреди..... | 5 |
|  Инструменти и помощни средства | 6 |
|  Ремонт | 7 |
| 4.1 Смяна на фасадния панел..... | 7 |
| 4.1.1 Сваляне на фасадния панел..... | 7 |
| 4.1.2 Монтиране на фасадния панел..... | 8 |
| 4.2 Смяна на чекмеджето за перилен препарат..... | 9 |
| 4.2.1 Сваляне на чекмеджето за перилен препарат..... | 9 |
| 4.2.2 Монтиране на чекмеджето за перилен препарат..... | 9 |
| 4.3 Смяна на дръжката на чекмеджето за перилен препарат..... | 10 |
| 4.3.1 Сваляне на дръжката на чекмеджето за перилен препарат..... | 10 |
| 4.3.2 Монтиране на дръжката на чекмеджето за перилен препарат..... | 10 |
| 4.4 Смяна на вратата..... | 11 |
| 4.4.1 Изваждане на вратата..... | 11 |
| 4.4.2 Монтиране на вратата..... | 11 |
| 4.5 Смяна на компонентите на вратата..... | 12 |
| 4.5.1 Сваляне на компонентите на вратата..... | 12 |
| 4.5.2 Монтиране на компонентите на вратата..... | 12 |
| 4.6 Смяна на пантата на вратата..... | 13 |
| 4.6.1 Сваляне на пантата на вратата..... | 13 |
| 4.6.2 Монтиране на пантата на вратата..... | 13 |
| 4.7 Смяна на уплътнението на вратата..... | 14 |
| 4.7.1 Сваляне на уплътнението на вратата..... | 14 |
| 4.7.2 Монтиране на уплътнението на вратата..... | 15 |

| | |
|--|----|
| 4.8 Смяна на ключа на вратата..... | 16 |
| 4.8.1 Сваляне на ключалката на вратата..... | 16 |
| 4.8.2 Монтиране на ключалката на вратата..... | 17 |
| 4.9 Смяна на осветлението на барабана..... | 18 |
| 4.9.1 Сваляне на осветлението на барабана..... | 18 |
| 4.9.2 Монтиране на осветлението на барабана..... | 18 |
| 4.10 Смяна на долния капак..... | 19 |
| 4.10.1 Сваляне на долния капак..... | 19 |
| 4.10.2 Монтиране на капака..... | 20 |
| 4.11 Смяна на предния панел..... | 21 |
| 4.11.1 Сваляне на предния панел..... | 21 |
| 4.11.2 Монтиране на предния панел..... | 22 |

i Относно този документ

1.1 Важна информация

1.1.1 Цел

Тези съвети за ремонт помагат на потребителя да ремонтира сам уреди в съответствие с регламента за екологосъобразно проектиране на уредите (от 03.2021 г.).

Те съдържат информация как да сменят определени резервни части, включително предупреждения и рискове.

Ако имате някакви въпроси, моля свържете се с нашия отдел за обслужване на клиенти. Носим отговорност за щети, само ако съветите за ремонт са спазени правилно.

1.2 Обяснение на символите

1.2.1 Нива на опасност

Предупредителните нива се състоят от символ и сигнална дума. Сигналната дума показва сериозността на опасността.





| Ниво на предупреждение | Значение |
|---|---|
|  ОПАСНОСТ | Неспазването на предупредителното съобщение ще доведе до смърт или сериозни наранявания. |
|  ПРЕДУПРЕЖДЕНИЕ | Неспазването на предупредителното съобщение може да доведе до смърт или сериозни наранявания. |
|  ВНИМАТЕЛНО | Неспазването на предупредителното съобщение може да доведе до леки наранявания. |
|  ВНИМАНИЕ! | Неспазването на предупредителното съобщение може да доведе до имуществени щети. |

Таблица 1: Нива на опасност

1.2.2 Символи за опасност

Символите за опасност са символични изображения, които дават индикация за вида опасност.

В този документ се използват следните символи за опасност:

| Символ за опасност | Значение |
|---|-------------------------------------|
|  | Общо предупредително съобщение |
|  | Опасност от електрическо напрежение |
|  | Риск от експлозия |
|  | Опасност от порязвания |

i Относно този документ





| Символ за опасност | Значение |
|--|----------------------------------|
|  | Опасност от премазване |
|  | Опасност от горещи повърхности |
|  | Опасност от силно магнитно поле |
|  | Опасност от нейонизиращо лъчение |

Таблица 2: Символи за опасност

1.2.3 Структура на предупрежденията

Предупрежденията в този документ имат стандартизиран външен вид и стандартизирана структура.

| | |
|--|---|
|  | <p>ОПАСНОСТ</p> <p>Вид и източник на опасността! Възможни последици от игнориране на опасността/предупреждението.</p> <ul style="list-style-type: none"> ▶ Мерки и забрани за предотвратяване на опасността. |
|--|---|

Следният пример показва предупреждение, което уведомява за токов удар, предизвикан от части под напрежение. Споменава се мярката за избягване на опасността.

| | |
|--|---|
|  | <p>ОПАСНОСТ</p> <p>Риск от токов удар поради части под напрежение! Смърт от токов удар</p> <ul style="list-style-type: none"> ▶ Изключете уредите от електрическото захранване поне 60 секунди преди започване на ремонта. |
|--|---|

1.2.4 Общи символи

В този документ се използват следните общи символи:







| Общ символ | Значение |
|---|--|
|  | Идентифициране на специален съвет (текст и/или графика) |
|  | Идентифициране на прост съвет (само текст) |
|  | Идентифициране на връзка към видео урок |
|  | Идентифициране на необходимите инструменти |
|  | Идентифициране на необходимите предварителни условия |
|  | Идентифициране на условие (ако ..., тогава ...) |
|  | Идентифициране на резултат |
| Старт | Идентифициране на ключ или бутон |
| [00123456] | Идентифициране на каталожен номер |
| Статус | Идентифициране на показания текст/прозорец (на дисплея на уреда) |

Таблица 3: Общи символи

2.1 Общи инструкции за безопасност

2.1.1 Всички домашни уреди

Риск от токов удар поради части под напрежение!

- Грешки при ремонти, включващи електрически компоненти, могат да доведат до токов удар!
- Разкачете уреда от електрическата мрежа за поне 60 секунди, преди да започнете работа.
- След ремонта трябва да се извърши проверка за безопасност съгласно VDE 0701 или в съответствие със специфичните за страната разпоредби.

Риск от нараняване от остри ръбове!

- Носете предпазни ръкавици.

Риск от премазване по време на ремонт, поддръжка, отстраняване на неизправности и сервиз поради тежки и движещи се компоненти

- Носете защитни обувки.
- Закрепете тежките компоненти, така че да не паднат.
- Не позволявайте контакт на части от тялото с движещи се компоненти.







Риск за безопасността/функцията на уреда!

- Използвайте само оригинални резервни части.

Риск от повреда на електростатично чувствителни компоненти (ESD)!





- Не докосвайте модулите, включително връзки и проводникови пътища.

Инструменти и помощни средства

| посочване | Подробности | Изображения |
|--|--|--|
| Помощен инструмент [15000155] | Инструмент за разхлабване на пластмасови части |  |
| Отвертка Torx T20 с отвор [00340764] | 100 мм, за винтове с предпазен щифт |  |
| Динамометричен ключ [15000441] | Динамометричен ключ 20 - 100 Nm | |
| Плоска отвертка [00340854] | Врърх 3,5 mm x 0,6 mm x 100 mm, Защитна изолация 1000 V AC |  |
| Плоска отвертка [00340855] | Врърх 5,5 mm x 1,0 mm x 125 mm, Защитна изолация 1000 V AC |  |
| Клещи с игловидни челюсти, под ъгъл [00341269] | Дължина 200 мм |  |
| Клещи резачки [00342182] | Дължина: 200 мм |  |

| посочване | Подробности | Изображения |
|-------------------------------|-------------------------|---|
| Комбиниран ключ [00340811] | гаечния ключ 10°mm, M6 |  |
| Combination wrench [00340814] | гаечния ключ 13°mm, M8 |  |
| Комбиниран ключ [00340817] | гаечния ключ 17 mm, M10 |  |
| Комбиниран ключ [15000459] | гаечния ключ 16°mm, M10 |  |

4.1 Смяна на фасадния панел

| | |
|--|---|
|  | <p>⚠ ВНИМАТЕЛНО</p> <p>Остри ръбове на корпуса! Наранявания от порязване</p> <ul style="list-style-type: none">▶ Носете предпазни ръкавици. |
|  | <p>⚠ ПРЕДУПРЕЖДЕНИЕ</p> <p>Приплъзване на наклонени уреди! Костни фрактури/наранявания от премазване</p> <ul style="list-style-type: none">▶ Укрепете уредите срещу приплъзване. |
|  | <p>⚠ ВНИМАТЕЛНО</p> <p>Риск от падащи части поради разхлабени винтове! Нараняване поради падащи части.</p> <ul style="list-style-type: none">▶ Закрепете компонента, така че да не падне. |
|  | <p>ВНИМАНИЕ!</p> <p>Риск от падащи части поради разхлабени винтове! Повреда на други части на уреда или в дома на клиента, напр. дъното.</p> <ul style="list-style-type: none">▶ Закрепете компонента, така че да не падне. |

Изискване:

- ✔ Уредът е изключен от захранването.
- ✔ Уредът е изключен от водоснабдителната мрежа.
- ✔ Уредите са свободно достъпни.
- ✔ [Чекмеджето за перилния препарат е свалено.→9](#)

4.1.1 Сваляне на фасадния панел

1. Освободете крепежния елемент (1).
2. Свалете капака (2).

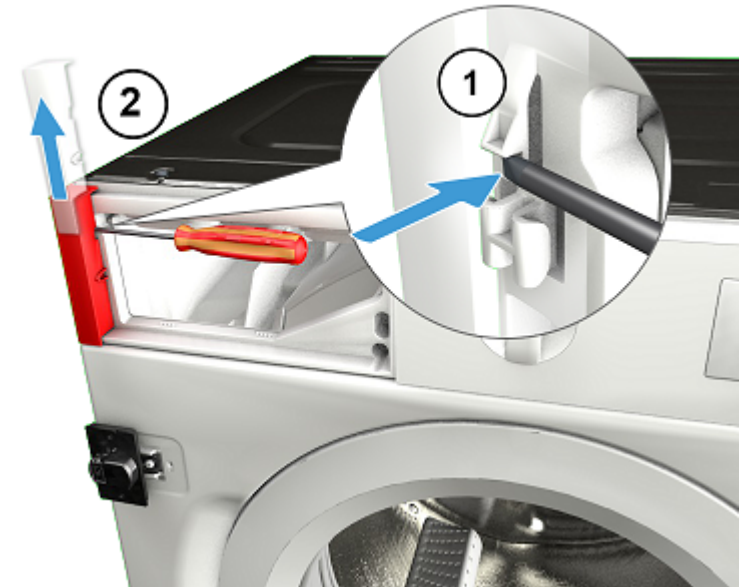

2. Свалете винтовете.



3. 1. Освободете крепежните елементи (1, 2).
2. Издърпайте фасадния панел отпред (3).

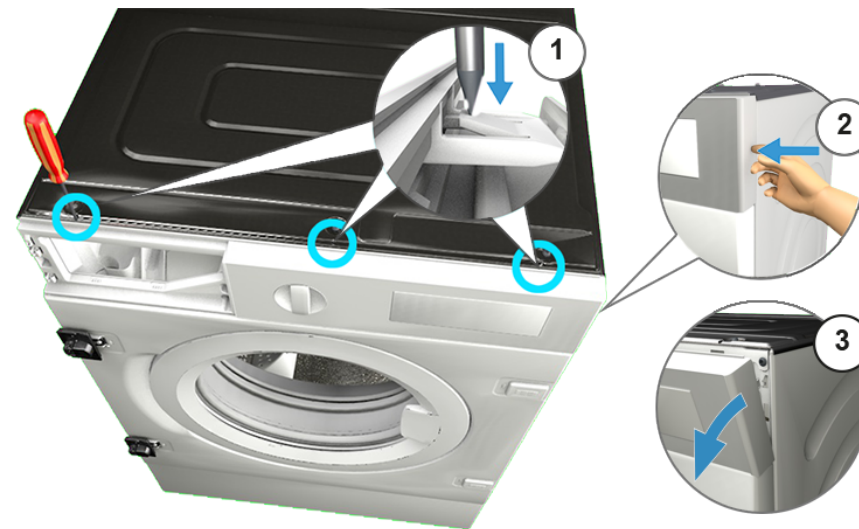

4. Свалете фасадния панел.

4.1.2 Монтиране на фасадния панел

► Монтирайте в обратен ред.

4.2 Смяна на чекмеджето за перилен препарат

Изискване:

- ✓ Уредът е изключен от захранването.
- ✓ Уредът е изключен от водоснабдителната мрежа.

4.2.1 Сваляне на чекмеджето за перилен препарат

1. Изтеглете чекмеджето за перилен препарат.
2. 1. Натиснете надолу върху подложката (1).
2. Свалете чекмеджето за перилен препарат (2).

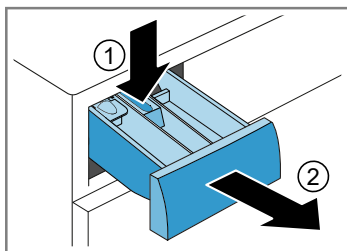

4.2.2 Монтиране на чекмеджето за перилен препарат

- ▶ Монтирайте в обратен ред.

4.3 Смяна на дръжката на чекмеджето за перилен препарат

Изискване:

- ✓ Уредът е изключен от захранването.
- ✓ Уредът е изключен от водоснабдителната мрежа.
- ✓ [Чекмеджето за перилния препарат е свалено.→9](#)

4.3.1 Сваляне на дръжката на чекмеджето за перилен препарат

1. Освободете крепежните елементи.

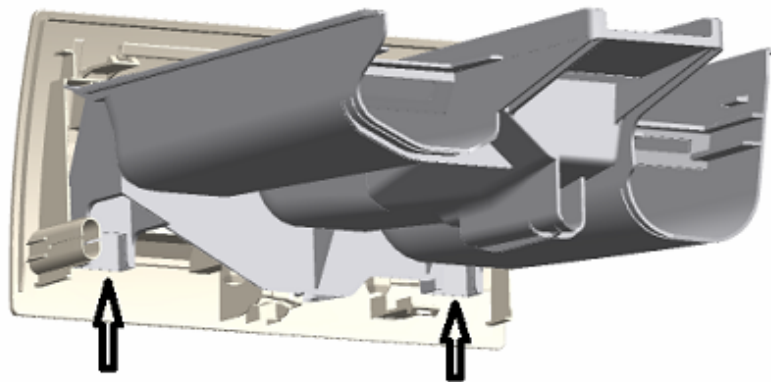

2. Свалете дръжката на чекмеджето за перилен препарат.

4.3.2 Монтиране на дръжката на чекмеджето за перилен препарат

- ▶ Монтирайте в обратен ред.

4.4 Смяна на вратата



⚠ ВНИМАТЕЛНО

Отворете областта на пантите!

Премазване/захващане на пръстите

- ▶ Не посягайте към областта на пантите.
- ▶ Носете предпазни ръкавици.

Изискване:

- ✔ Уредът е изключен от захранването.
- ✔ Уредът е изключен от водоснабдителната мрежа.
- ✔ Вратата е отворена.
- ✔ Мебелният панел е свален.

4.4.1 Изваждане на вратата

1.



ВНИМАНИЕ!

Риск от падащи части поради разхлабени винтове!

Повреда на други части на уреда или в дома на клиента, напр. дъното.

- ▶ Закрепете компонента, така че да не падне.



⚠ ВНИМАТЕЛНО

Риск от падащи части поради разхлабени винтове!

Нараняване поради падащи части.

- ▶ Закрепете компонента, така че да не падне.

Свалете винтовете (1).

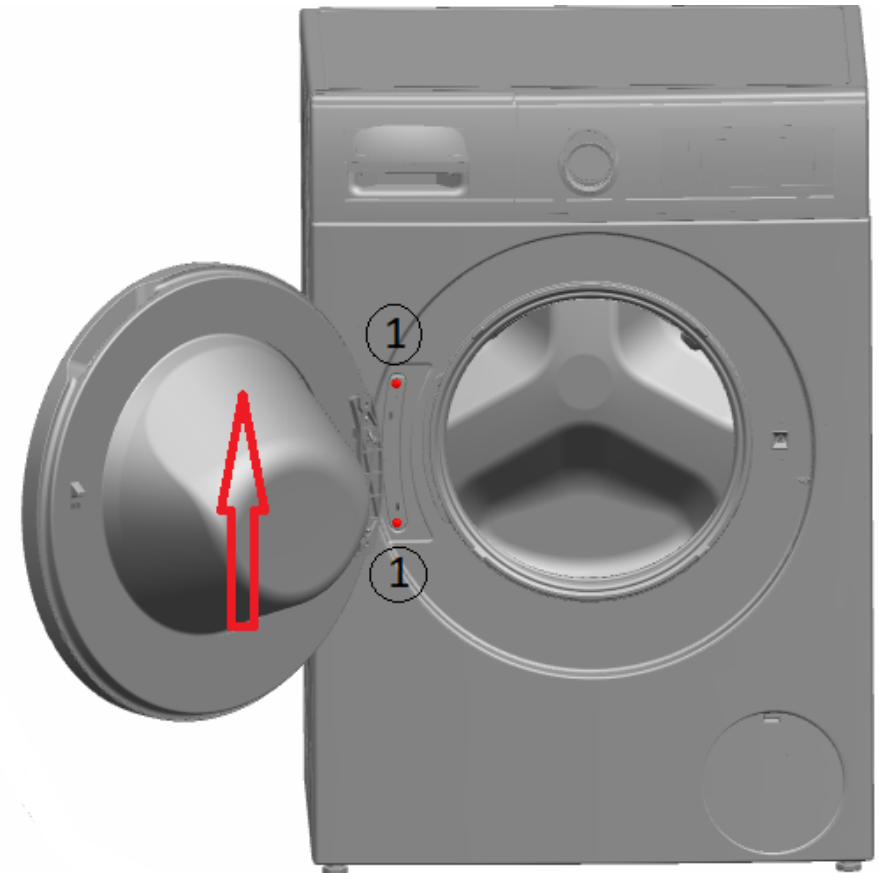

2. Извадете вратата нагоре.

4.4.2 Монтиране на вратата

- ▶ Монтирайте в обратен ред.

4.5 Смяна на компонентите на вратата



⚠ ВНИМАТЕЛНО

Отворете областта на пантите!

Премазване/захващане на пръстите

- ▶ Не посягайте към областта на пантите.
- ▶ Носете предпазни ръкавици.

Изискване:

- ✔ Уредът е изключен от захранването.
- ✔ Уредът е изключен от водоснабдителната мрежа.
- ✔ Мебелният панел е свален.
- ✔ [Вратата е свалена. → 11](#)

4.5.1 Свляяне на компонентите на вратата

- ▶ Разглобете вратата отвън навътре.

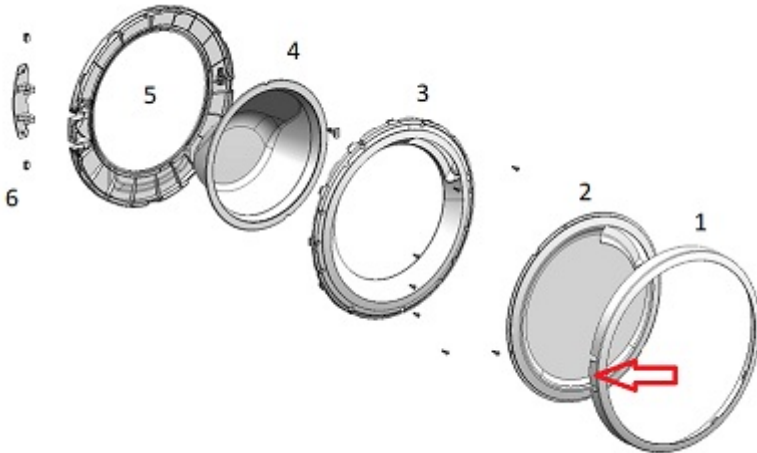

4.5.2 Монтиране на компонентите на вратата

- ▶ Монтирайте в обратен ред.

4.6 Смяна на пантата на вратата



⚠ ВНИМАТЕЛНО

Отворете областта на пантите!

Премазване/захващане на пръстите

- ▶ Не посягайте към областта на пантите.
- ▶ Носете предпазни ръкавици.

Изискване:

- ✔ Уредът е изключен от захранването.
- ✔ Уредът е изключен от водоснабдителната мрежа.

4.6.1 Сваляне на пантата на вратата

1. Разхлабете двата винта.
2. Извадете вратата.
3. Разглобете вратата отвън навътре.

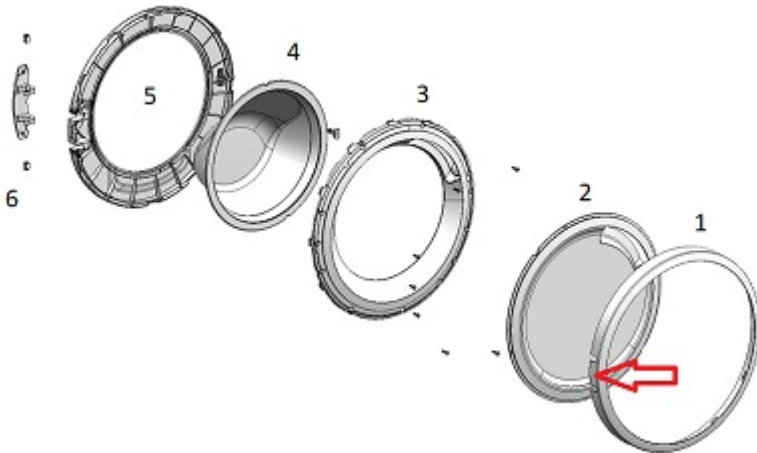



4. Свадете пантата на вратата.

4.6.2 Монтиране на пантата на вратата

- ▶ Монтирайте в обратен ред.

4.7 Смяна на уплътнението на вратата

| | |
|--|---|
|  | <p>⚠ ВНИМАТЕЛНО</p> <p>Остри ръбове на корпуса! Наранявания от порязване</p> <ul style="list-style-type: none"> ▶ Носете предпазни ръкавици. |
|--|---|

| | |
|--|---|
|  | <p>⚠ ВНИМАТЕЛНО</p> <p>Риск от падащи части поради разхлабени винтове! Нараняване поради падащи части.</p> <ul style="list-style-type: none"> ▶ Закрепете компонента, така че да не падне. |
|--|---|

| | |
|--|---|
|  | <p>ВНИМАНИЕ!</p> <p>Риск от падащи части поради разхлабени винтове! Повреда на други части на уреда или в дома на клиента, напр. дъното.</p> <ul style="list-style-type: none"> ▶ Закрепете компонента, така че да не падне. |
|--|---|

Изискване:

- ✓ Уредът е изключен от захранването.
- ✓ Уредът е изключен от водоснабдителната мрежа.
- ✓ Уредите са свободно достъпни.
- ✓ [Чекмеджето за перилния препарат е свалено.→9](#)
- ✓ Фасадният панел е свален.
- ✓ [Вратата е свалена.→11](#)
- ✓ [Долният капак е свален.→19](#)

4.7.1 Сваляне на уплътнението на вратата

1. Разхлабете фиксатора на осветлението на барабана.



2.

| | |
|---|---|
|  | <p>ВНИМАНИЕ!</p> <p>Риск от повредена повърхност! Повърхността на уреда може да се надраска, ако използвате неправилни инструменти.</p> <ul style="list-style-type: none"> ▶ Използвайте само пластмасови инструменти за подмяна на обтягащия пръстен. |
|---|---|

Свалете обтягащия пръстен от уплътнението с пластмасов инструмент.

3. Освободете уплътнението на вратата от предния панел.
4. Освободете конектора на кабела от ключалката на вратата.

5. Разхлабете винтовете в указания ред.



6. Свалете предния панел.

7. Изключете всички съединителни елементи за маркучи.

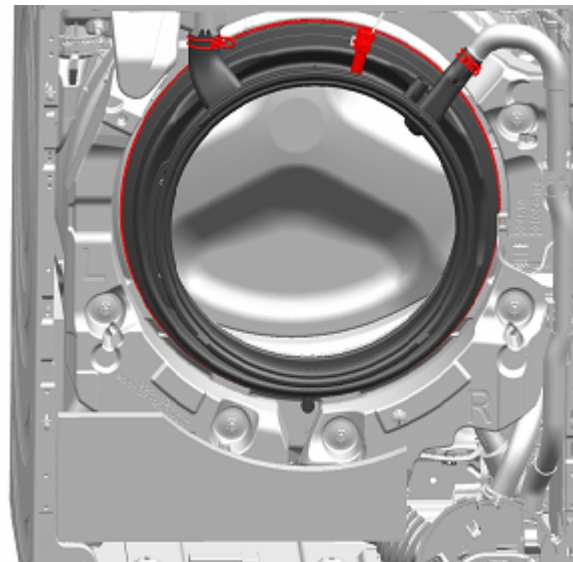

8. Извадете уплътнението на вратата.

4.7.2 Монтиране на уплътнението на вратата

► Монтирайте в обратен ред.

4.8 Смяна на ключа на вратата

Като производител ние сме задължени да предоставим на потребителите като резервна част ключалка за вратата, включително инструкция за ремонт в съответствие с Регламента (ЕС) 2019/2023. Бихме искали да отбележим обаче, че след смяната на ключалката на вратата, е необходимо да се извърши електротехническа проверка за безопасност от квалифициран електротехник, преди уредът да бъде пуснат в експлоатация. Това лице трябва да бъде с потвърдена квалификация съгласно специфичните за страната закони, разпоредби и стандарти.

| | |
|--|--|
|  | ⚠ ОПАСНОСТ |
| | <p>Риск от токов удар поради части под напрежение! Опасност за живота от токов удар в случай на неправилен ремонт</p> <ul style="list-style-type: none"> ▶ Електрическите части трябва да се ремонтират от квалифицирани електротехници. ▶ След ремонта трябва да се извърши проверка за безопасност съгласно VDE 0701 или в съответствие със специфичните за страната разпоредби. |

| | |
|--|---|
|  | ⚠ ВНИМАТЕЛНО |
| | <p>Остри ръбове на корпуса! Наранявания от порязване</p> <ul style="list-style-type: none"> ▶ Носете предпазни ръкавици. |

| | |
|---|--|
|  | ⚠ ПРЕДУПРЕЖДЕНИЕ |
| | <p>Приплъзване на наклонени уреди! Костни фрактури/наранявания от премазване</p> <ul style="list-style-type: none"> ▶ Укрепете уредите срещу приплъзване. |

| | |
|--|---|
|  | ⚠ ВНИМАТЕЛНО |
| | <p>Риск от падащи части поради разхлабени винтове! Нараняване поради падащи части.</p> <ul style="list-style-type: none"> ▶ Закрепете компонента, така че да не падне. |

| | |
|--|--|
|  | ВНИМАНИЕ! |
| | <p>Риск от падащи части поради разхлабени винтове! Повреда на други части на уреда или в дома на клиента, напр. дъното.</p> <ul style="list-style-type: none"> ▶ Закрепете компонента, така че да не падне. |

Изискване:

- ✔ Уредът е изключен от захранването.
- ✔ Уредът е изключен от водоснабдителната мрежа.
- ✔ Уредите са свободно достъпни.
- ✔ Мебелният панел е свален.
- ✔ Фасадният панел е свален.
- ✔ [Вратата е свалена. → 11](#)
- ✔ Обтягащият пръстен е свален.
- ✔ Предният панел е свален.
- ✔ Уплътнението на вратата е свалено.

4.8.1 Сваляне на ключалката на вратата

1. Изключете щепсела на ключалката на вратата.
2. Освободете ключалката на вратата.



3. Свалете ключалката на вратата.



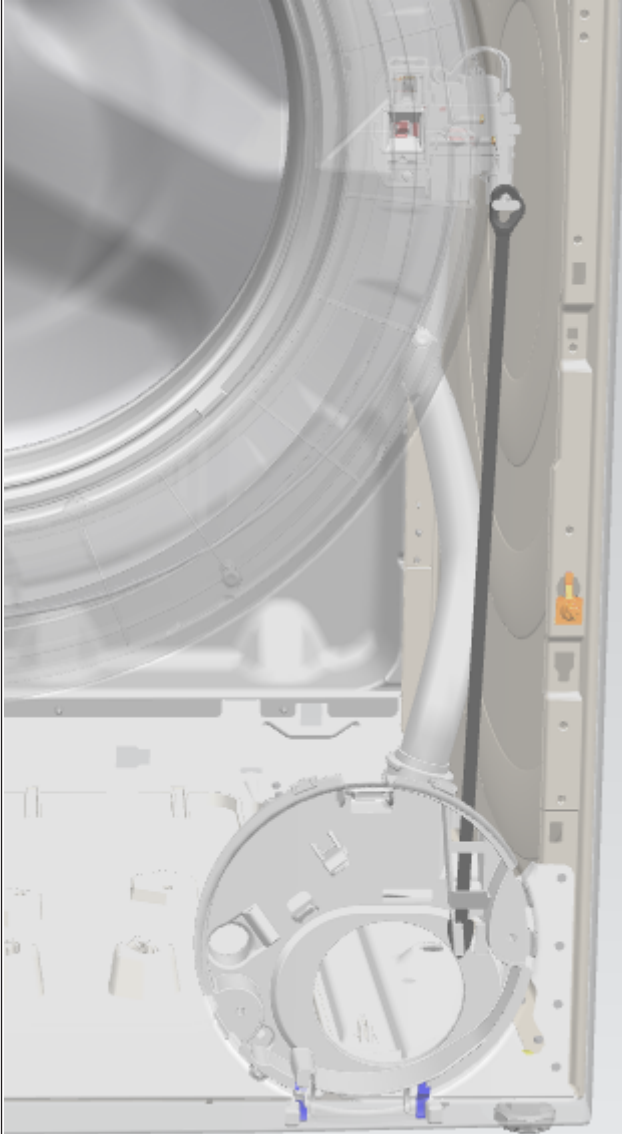

4.8.2 Монтиране на ключалката на вратата

Ключалката на вратата трябва да е в правилното положение, за да осигури функцията за аварийно отваряне на вратата на уреда.



- ▶ Монтирайте в обратен ред.

4.9 Смяна на осветлението на барабана

| | |
|--|--|
|  | ⚠ ВНИМАТЕЛНО Остри ръбове на корпуса! Наранявания от порязване ▶ Носете предпазни ръкавици. |
|  | ⚠ ПРЕДУПРЕЖДЕНИЕ Приплъзване на наклонени уреди! Костни фрактури/наранявания от премазване ▶ Укрепете уредите срещу приплъзване. |
|  | ⚠ ВНИМАТЕЛНО Риск от падащи части поради разхлабени винтове! Нараняване поради падащи части. ▶ Закрепете компонента, така че да не падне. |
|  | ВНИМАНИЕ! Риск от падащи части поради разхлабени винтове! Повреда на други части на уреда или в дома на клиента, напр. дъното. ▶ Закрепете компонента, така че да не падне. |

Изискване:

- ✓ Уредът е изключен от захранването.
- ✓ Уредът е изключен от водоснабдителната мрежа.
- ✓ Уредите са свободно достъпни.
- ✓ [Чекмеджето за перилния препарат е свалено. →9](#)
- ✓ Фасадният панел е свален.

4.9.1 Сваляне на осветлението на барабана

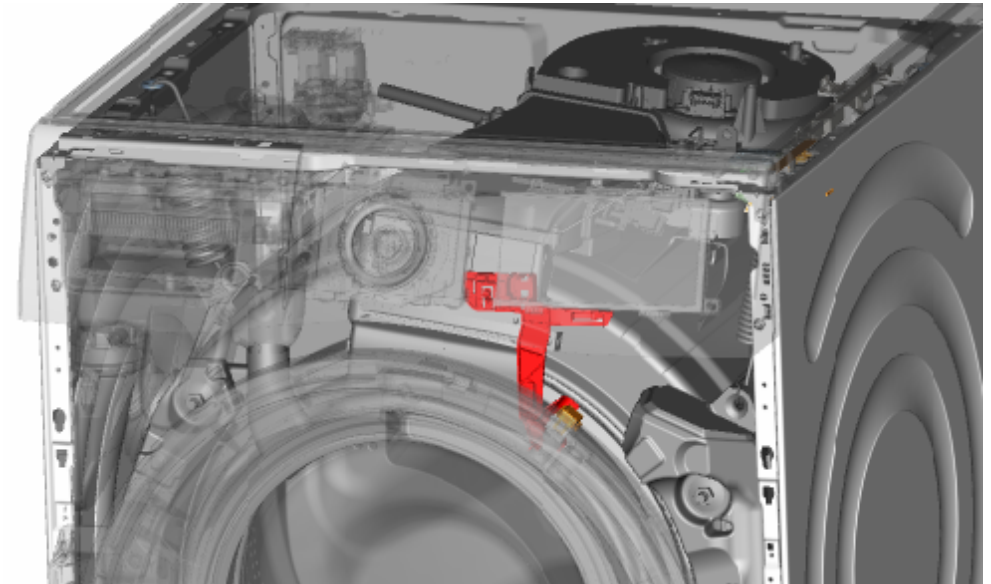

1. Издърпайте държача на осветлението на барабана от уреда.
2. Изключете електрическите връзки.
3. Свалете осветлението на барабана от държача.

4.9.2 Монтиране на осветлението на барабана

- ▶ Монтирайте в обратен ред.

4.10 Смяна на долния капак



Фиг. 1: Капак за долната група

Изискване:

- ✔ Уредът е изключен от захранването.
- ✔ Уредът е изключен от водоснабдителната мрежа.
- ✔ Мебелният панел е свален.

4.10.1 Сваляне на долния капак

Изискване:

- ✔ Уредът е изключен от захранването.
- ✔ Уредът е изключен от водоснабдителната мрежа.

1. Свалете долния капак.

2. Отделете маркуча от държача.

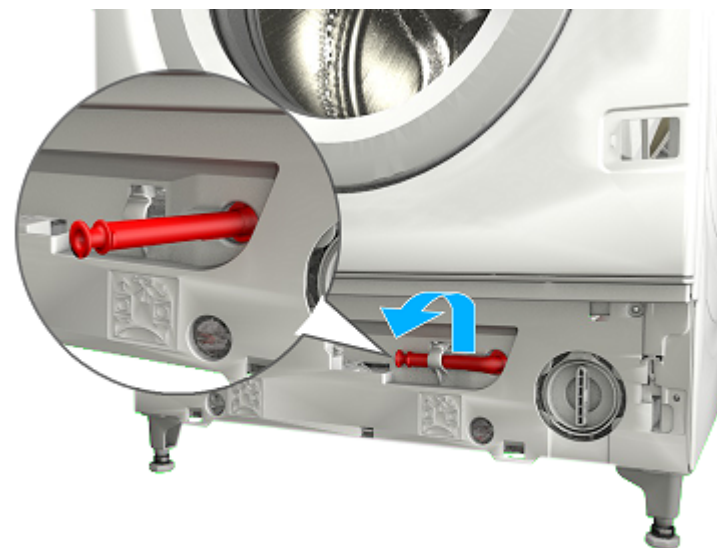

3. 1. Развийте винта (1).
2. Натиснете задържащата точка и свалете надолу (2).

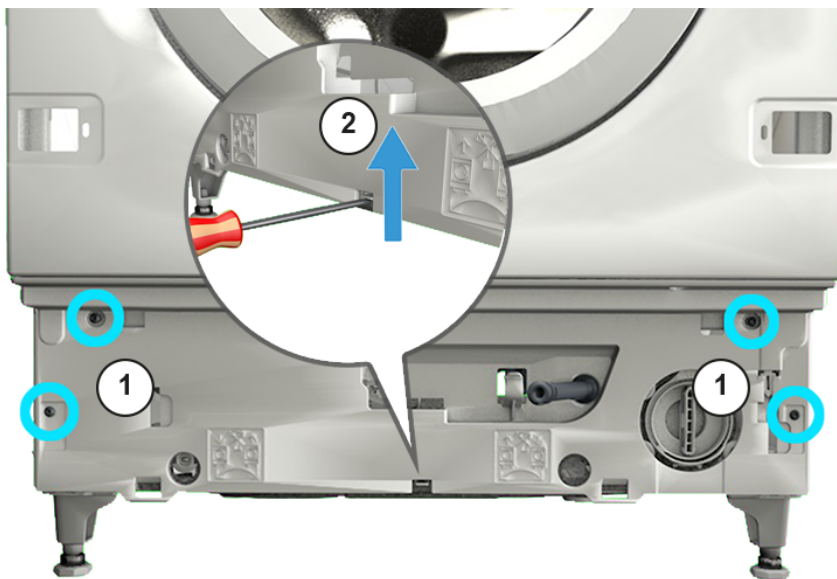

4. Издърпайте капака на долната група и го извадете напред.

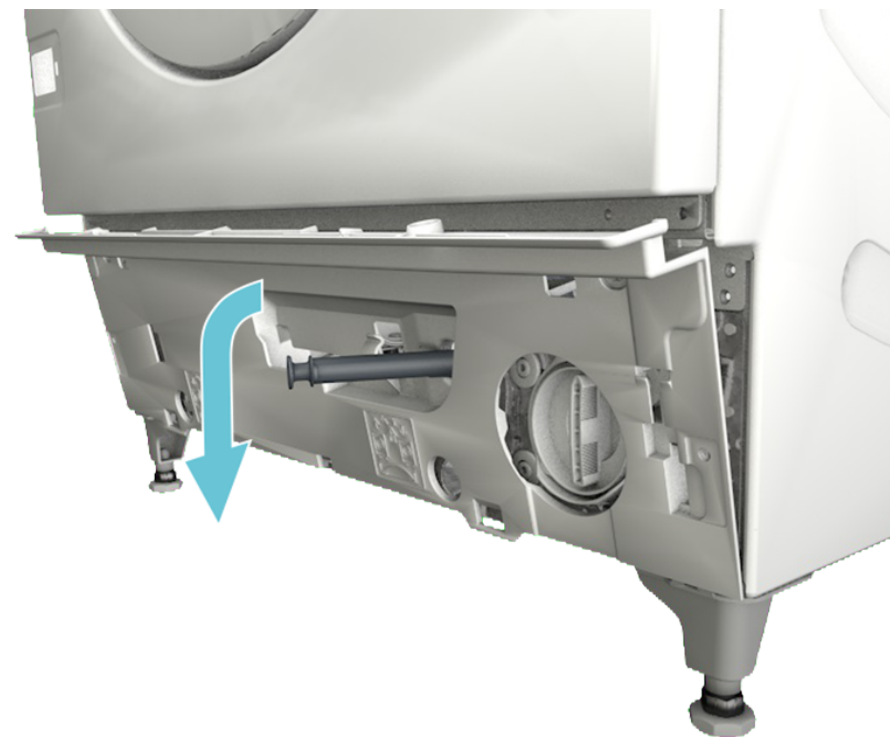

5. Издърпайте маркуча от капака.

4.10.2 Монтиране на капака

- ▶ Монтирайте в обратен ред.

4.11 Смяна на предния панел

| | |
|--|---|
|  | <p>⚠ ВНИМАТЕЛНО</p> <p>Остри ръбове на корпуса! Наранявания от порязване</p> <ul style="list-style-type: none"> ▶ Носете предпазни ръкавици. |
|--|---|

Изискване:

- ✓ Уредът е изключен от захранването.
- ✓ Уредът е изключен от водоснабдителната мрежа.
- ✓ Уредите са свободно достъпни.
- ✓ [Чекмеджето за перилния препарат е свалено. → 9](#)
- ✓ Мебелният панел е свален.
- ✓ [Вратата е свалена. → 11](#)
- ✓ Уплътнението на вратата е свалено.

4.11.1 Сваляне на предния панел

1. Разхлабете фиксатора на осветлението на барабана.

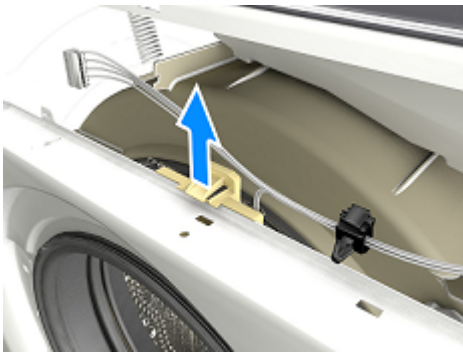

2.

| | |
|---|---|
|  | <p>⚠ ВНИМАТЕЛНО</p> <p>Риск от падащи части поради разхлабени винтове! Нараняване поради падащи части.</p> <ul style="list-style-type: none"> ▶ Закрепете компонента, така че да не падне. |
|---|---|

| | |
|---|---|
|  | <p>ВНИМАНИЕ!</p> <p>Риск от падащи части поради разхлабени винтове! Повреда на други части на уреда или в дома на клиента, напр. дъното.</p> <ul style="list-style-type: none"> ▶ Закрепете компонента, така че да не падне. |
|---|---|

Разхлабете винтовете в указания ред.







3. Свалете предния панел.

4.11.2 Монтиране на предния панел

▶ Монтирайте в обратен ред.

Savjeti za popravak - Perilica rublja

| | |
|--|-----------|
|  O ovom dokumentu | 24 |
| 1.1 Važne informacije..... | 24 |
| 1.1.1 Svrha..... | 24 |
| 1.2 Objasnjenje oznaka..... | 24 |
| 1.2.1 Stupnjevi opasnosti..... | 24 |
| 1.2.2 Oznake opasnosti..... | 24 |
| 1.2.3 Struktura upozorenja..... | 25 |
| 1.2.4 Opće oznake..... | 25 |
|  Sigurnost | 26 |
| 2.1 Opće sigurnosne upute..... | 26 |
| 2.1.1 Svi kućanski uređaji..... | 26 |
|  Alat i pomagala | 27 |
|  Popravak | 28 |
| 4.1 Zamjena ploče..... | 28 |
| 4.1.1 Uklanjanje ploče..... | 28 |
| 4.1.2 Postavljanje ploče..... | 29 |
| 4.2 Zamjena ladice za deterdžent..... | 30 |
| 4.2.1 Uklanjanje ladice za deterdžent..... | 30 |
| 4.2.2 Postavljanje ladice za deterdžent..... | 30 |
| 4.3 Zamjena ručice ladice za deterdžent..... | 31 |
| 4.3.1 Uklanjanje ručice ladice za deterdžent..... | 31 |
| 4.3.2 Postavljanje ručice ladice za deterdžent..... | 31 |
| 4.4 Zamjena vrata..... | 32 |
| 4.4.1 Uklanjanje vrata..... | 32 |
| 4.4.2 Postavljanje vrata..... | 32 |
| 4.5 Zamjena sastavnih dijelova vrata..... | 33 |
| 4.5.1 Uklanjanje sastavnih dijelova vrata..... | 33 |
| 4.5.2 Postavljanje sastavnih dijelova vrata..... | 33 |
| 4.6 Zamjena zgloba vrata..... | 34 |
| 4.6.1 Uklanjanje zgloba vrata..... | 34 |
| 4.6.2 Postavljanje zgloba vrata..... | 34 |
| 4.7 Zamjena brtve vrata..... | 35 |
| 4.7.1 Uklanjanje brtve vrata..... | 35 |
| 4.7.2 Postavljanje brtve vrata..... | 36 |

| | |
|--|----|
| 4.8 Zamjena brave vrata..... | 37 |
| 4.8.1 Uklanjanje brave vrata..... | 37 |
| 4.8.2 Postavljanje brave vrata..... | 38 |
| 4.9 Zamjena svjetla bubnja..... | 39 |
| 4.9.1 Uklanjanje svjetla bubnja..... | 39 |
| 4.9.2 Postavljanje svjetla bubnja..... | 39 |
| 4.10 Zamjena donjeg poklopca..... | 40 |
| 4.10.1 Uklanjanje donjeg poklopca..... | 40 |
| 4.10.2 Postavljanje poklopca..... | 41 |
| 4.11 Zamjena prednje ploče..... | 42 |
| 4.11.1 Uklanjanje prednje ploče..... | 42 |
| 4.11.2 Postavljanje prednje ploče..... | 43 |

i O ovom dokumentu

1.1 Važne informacije

1.1.1 Svrha

Ove upute za popravak služe kao podrška korisnicima prilikom samostalnog popravljivanja uređaja u skladu s primjenjivom Direktivom o ekološkom dizajnu (od ožujka 2021.).

One sadrže informacije o zamjeni određenih rezervnih dijelova, kao i napomene o upozorenjima i opasnostima.

Ako imate dodatna pitanja, obratite se našoj službi za korisnike. Mi snosimo odgovornost za oštećenja samo u slučaju pridržavanja uputa za popravak.

1.2 Objašnjenje oznaka

1.2.1 Stupnjevi opasnosti

Stupnjevi upozorenja sastoje se od oznake i signalne riječi. Signalna riječ ukazuje na ozbiljnost opasnosti.





| Stupanj upozorenja | Značenje |
|---|---|
|  OPASNOST | Nepridržavanje poruke upozorenja rezultirat će smrtnim ili teškim ozljedama. |
|  UPOZORENJE | Nepridržavanje poruke upozorenja može rezultirati smrtnim ili teškim ozljedama. |
|  OPREZ | Nepridržavanje poruke upozorenja može rezultirati lakšim ozljedama. |
|  POZORI! | Nepridržavanje poruke upozorenja može rezultirati oštećenjem imovine. |

Tablica 1: Stupnjevi opasnosti



1.2.2 Oznake opasnosti

Oznake opasnosti simbolička su reprezentacija s oznakom vrste opasnosti.

U ovom dokumentu koriste se sljedeće oznake opasnosti:

| Oznaka opasnosti | Značenje |
|---|--------------------------------|
|  | Opća poruka upozorenja |
|  | Opasnost od električnog napona |
|  | Opasnost od eksplozije |
|  | Opasnost od porezotina |
|  | Opasnost od prignječenja |

O ovom dokumentu

| Oznaka opasnosti | Značenje |
|--|--------------------------------------|
|  | Opasnost od vrućih površina |
|  | Opasnost od jakog magnetskog polja |
|  | Opasnost od neionizirajućeg zračenja |

Tablica 2: Oznake opasnosti

1.2.3 Struktura upozorenja

Upozorenja u ovom dokumentu imaju normirani izgled i strukturu.



| | |
|--|---|
|  | <div style="background-color: red; color: white; padding: 2px; text-align: center;"> OPASNOST</div> <p>Vrsta i izvor opasnosti! Moguće posljedice zanemarivanja opasnosti/upozorenja.</p> <ul style="list-style-type: none"> ▶ Mjere i zabrane za sprječavanje opasnosti. |
|--|---|





Sljedeći primjer pokazuje upozorenje na strujni udar od dijelova koji provode struju. Spominje se mjera za izbjegavanje opasnosti.

| | |
|---|--|
|  | <div style="background-color: red; color: white; padding: 2px; text-align: center;"> OPASNOST</div> <p>Opasnost od strujnog udara zbog dijelova koji provode struju! Smrt od strujnog udara</p> <ul style="list-style-type: none"> ▶ Isključite uređaj iz električnog napajanja najmanje 60 sekundi prije izvođenja popravaka. |
|---|--|

1.2.4 Opće oznake

U ovom dokumentu koriste se sljedeće opće oznake:

| Opća znaka | Značenje |
|--|---|
|  | Oznaka posebnog savjeta (tekst i/ili grafika) |
|  | Oznaka jednostavnog savjeta (samo tekst) |
|  | Oznaka veze na videovodič |

| Opća znaka | Značenje |
|---|--|
|  | Oznaka potrebnog alata |
|  | Oznaka potrebnih preduvjeta |
|  | Oznaka uvjeta (ako ..., tad ...) |
|  | Oznaka rezultata |
| [Početak] | Oznaka tipke ili gumba |
| [00123456] | Oznaka broja materijala |
| Status | Oznaka prikazanog teksta / prozor (na zaslonu uređaja) |

Tablica 3: Opće oznake

2.1 Opće sigurnosne upute

2.1.1 Svi kućanski uređaji

Opasnost od strujnog udara zbog dijelova koji provode struju!

- Pogreške izazvane popravcima električnih sastavnih dijelova mogu dovesti do strujnog udara!
- Isključite uređaj iz struje na najmanje 60 sekundi prije početka radova.
- Nakon popravka provedite sigurnosni test u skladu s VDE 0701 ili nacionalnim propisima.

Opasnost od ozljeda zbog oštih rubova!

- Nosite zaštitne rukavice.

Opasnost od prignječenja tijekom izvođenja radova na popravcima, održavanju, rješavanju problema i servisiranju teških i pokretnih sastavnih dijelova

- Nosite zaštitnu obuću.
- Osigurajte teške sastavne dijelove od pada.
- Nemojte umetati dijelove tijela u pokretne sastavne dijelove.







Opasnost za sigurnost/rad uređaja!

- Koristite samo originalne rezervne dijelove.

Opasnost od oštećenja elektrostatički osjetljivih sastavnih dijelova (ESD)!

- Nemojte dodirivati module, uključujući priključke i rute vodiča.

Alat i pomagala

| Oznaka | Pojedinosti | Slike |
|--|--|--|
| Pomoćni alat [15000155] | Alat za otpuštanje plastičnih dijelova |  |
| Odvijač Torx T20 s provrtom [00340764] | 100 mm, za vijke sa sigurnosnim klinom |  |
| Moment ključ [15000441] | Moment ključ 20 - 100 Nm | |
| Odvijač s utorom [00340854] | Nož 3,5 mm x 0,6 mm x 100 mm, zaštitna izolacija 1000 V AC |  |
| Odvijač s utorom [00340855] | Nož 5,5 mm x 1,0 mm x 125 mm, zaštitna izolacija 1000 V AC |  |
| Kliješta s iglenim nosom, kutni uzorak [00341269] | Duljina 200 mm |  |
| Kliješta za bočno rezanje [00342182] | Duljina: 200 mm |  |

| Oznaka | Pojedinosti | Slike |
|----------------------------------|----------------------------|---|
| Kombinirani ključ [00340811] | Veličina ključa 10°mm, M6 |  |
| Combination wrench [00340814] | Veličina ključa 13°mm, M8 |  |
| Kombinirani ključ [00340817] | Veličina ključa 17 mm, M10 |  |
| Kombinirani ključ [15000459] | Veličina ključa 16°mm, M10 |  |

4.1 Zamjena ploče



⚠️ OPREZ

Oštri rubovi kućišta!

Porezotine

- ▶ Nosite zaštitne rukavice.



⚠️ UPOZORENJE

Isklizavanje nagnutih uređaja!

Puknuća kostiju / ozljede od prignječenja

- ▶ Osigurajte uređaje od isklizavanja.



⚠️ OPREZ

Opasnost od padanja dijelova zbog otpuštenih vijaka!

Ozljeda od dijelova koji padaju.

- ▶ Osigurajte sastavne dijelove od pada.



POZOR!

Opasnost od padanja dijelova zbog otpuštenih vijaka!

Oštećenje drugih dijelova uređaja ili objekta klijenta, npr. poda.

- ▶ Osigurajte sastavne dijelove od pada.

Zahtjev:

- ✓ Uređaj je isključen iz napajanja.
- ✓ Uređaj je isključen iz priključka za dovod vode.
- ✓ Uređaju se može slobodno pristupiti.
- ✓ [Ladica za deterdžent je uklonjena.→30](#)

4.1.1 Uklanjanje ploče

1. Otpustite zahvatni element (1).
2. Uklonite poklopac (2).

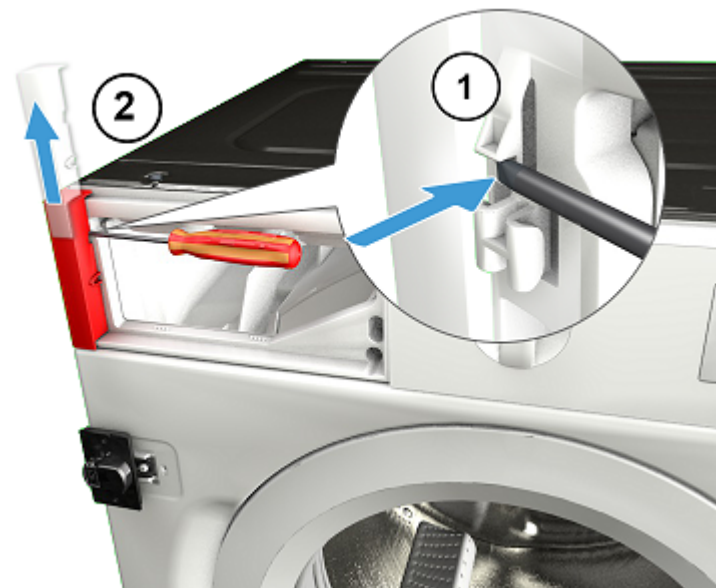

2. Uklonite vijke.



3. 1. Otpustite zahvatne elemente (1, 2).
2. Izvucite ploču naprijed (3).

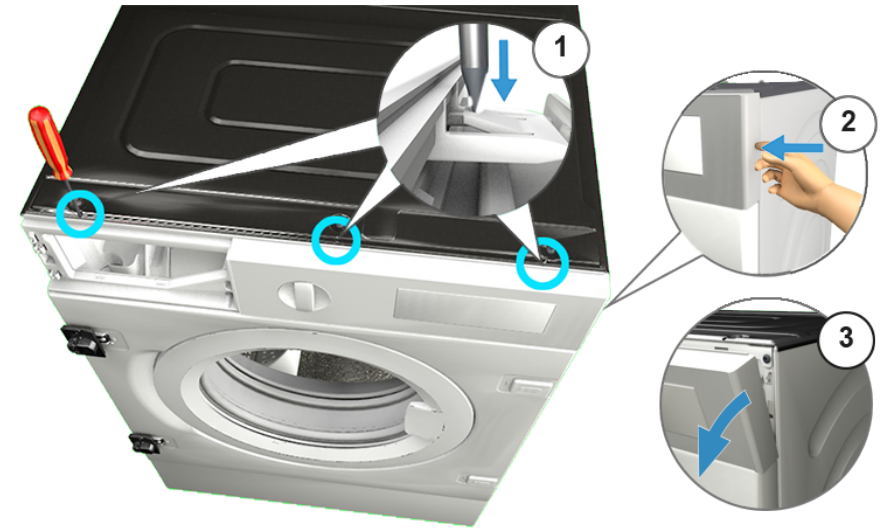

4. Uklonite ploču.

4.1.2 Postavljanje ploče

► Postavite obratnim redoslijedom.

4.2 Zamjena ladice za deterdžent

Zahtjev:

- ✓ Uređaj je isključen iz napajanja.
- ✓ Uređaj je isključen iz priključka za dovod vode.

4.2.1 Uklanjanje ladice za deterdžent

1. Izvucite ladicu za deterdžent.
2. 1. Pritisnite uložak (1).
2. Uklonite ladicu za deterdžent (2).

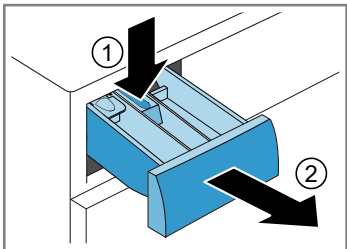

4.2.2 Postavljanje ladice za deterdžent

- ▶ Postavite obratnim redoslijedom.

4.3 Zamjena ručice ladice za deterdžent

Zahtjev:

- ✓ Uređaj je isključen iz napajanja.
- ✓ Uređaj je isključen iz priključka za dovod vode.
- ✓ [Ladica za deterdžent je uklonjena.→30](#)

4.3.1 Uklanjanje ručice ladice za deterdžent

1. Otpustite zahvatne elemente.

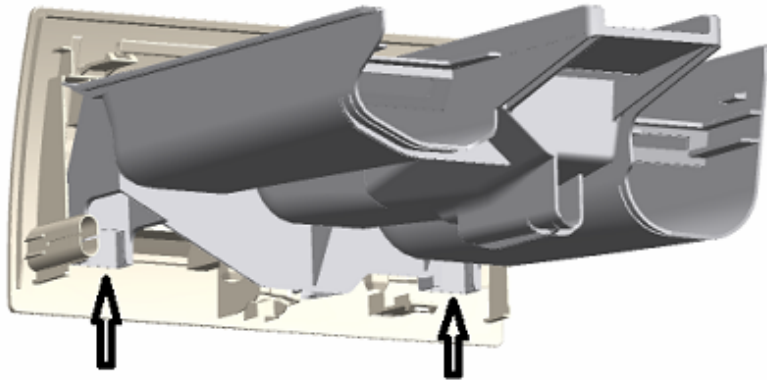

2. Uklonite ručicu ladice za deterdžent.

4.3.2 Postavljanje ručice ladice za deterdžent

- ▶ Postavite obratnim redoslijedom.

4.4 Zamjena vrata



⚠️ OPREZ

Otvorite područje zgloba!

Prignječenje/zaglavljivanje prstiju

- ▶ Nemojte posezati rukama u područje zgloba.
- ▶ Nosite zaštitne rukavice.

Zahtjev:

- ✔ Uređaj je isključen iz napajanja.
- ✔ Uređaj je isključen iz priključka za dovod vode.
- ✔ Vrata su otvorena.
- ✔ Ploča namještaja je uklonjena.

4.4.1 Uklanjanje vrata

1.



POZOR!

Opasnost od padanja dijelova zbog otpuštenih vijaka!

Oštećenje drugih dijelova uređaja ili objekta klijenta, npr. poda.

- ▶ Osigurajte sastavne dijelove od pada.



⚠️ OPREZ

Opasnost od padanja dijelova zbog otpuštenih vijaka!

Ozljeda od dijelova koji padaju.

- ▶ Osigurajte sastavne dijelove od pada.

Uklonite vijke (1).

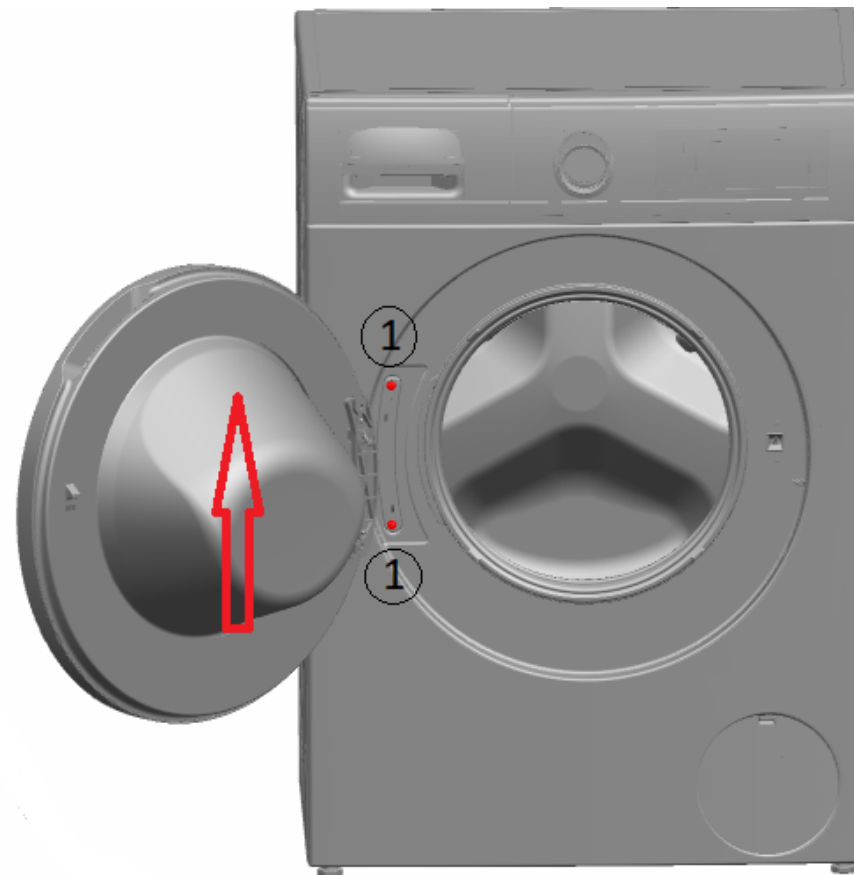

2. Uklonite vrata prema gore.

4.4.2 Postavljanje vrata

- ▶ Postavite obratnim redoslijedom.

4.5 Zamjena sastavnih dijelova vrata

| | |
|--|--|
|  | ⚠ OPREZ |
| | Otvorite područje zgloba! Prignječenje/zaglavljivanje prstiju ▶ Nemojte posezati rukama u područje zgloba. ▶ Nosite zaštitne rukavice. |

Zahtjev:

- ✔ Uređaj je isključen iz napajanja.
- ✔ Uređaj je isključen iz priključka za dovod vode.
- ✔ Ploča namještaja je uklonjena.
- ✔ [Vrata su uklonjena.→32](#)

4.5.1 Uklanjanje sastavnih dijelova vrata

- ▶ Rastavite vrata počevši s vanjske prema unutarnjoj strani.

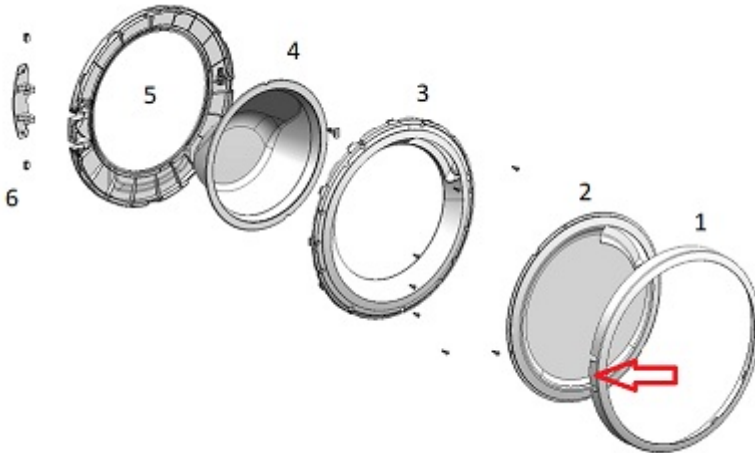

4.5.2 Postavljanje sastavnih dijelova vrata

- ▶ Postavite obratnim redoslijedom.

4.6 Zamjena zgloba vrata



OPREZ

Otvorite područje zgloba!

Prignječenje/zaglavljivanje prstiju

- ▶ Nemojte posezati rukama u područje zgloba.
- ▶ Nosite zaštitne rukavice.

Zahtjev:

- ✔ Uređaj je isključen iz napajanja.
- ✔ Uređaj je isključen iz priključka za dovod vode.

4.6.1 Uklanjanje zgloba vrata

1. Otpustite dva vijka.
2. Uklonite vrata.
3. Rastavite vrata počevši s vanjske prema unutarnjoj strani.

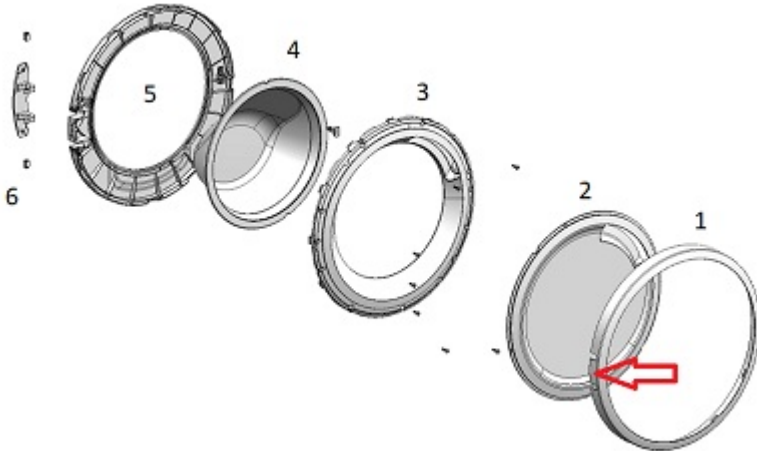



4. Uklonite zglob vrata.

4.6.2 Postavljanje zgloba vrata

- ▶ Postavite obratnim redoslijedom.

4.7 Zamjena brtve vrata

| | |
|--|---|
|  | OPREZ Oštri rubovi kućišta! Porezotine ▶ Nosite zaštitne rukavice. |
|--|---|

| | |
|--|--|
|  | OPREZ Opasnost od padanja dijelova zbog otpuštenih vijaka! Ozljeda od dijelova koji padaju. ▶ Osigurajte sastavne dijelove od pada. |
|--|--|

| | |
|--|---|
|  | POZOR! Opasnost od padanja dijelova zbog otpuštenih vijaka! Oštećenje drugih dijelova uređaja ili objekta klijenta, npr. poda. ▶ Osigurajte sastavne dijelove od pada. |
|--|---|

Zahtjev:

- ✓ Uređaj je isključen iz napajanja.
- ✓ Uređaj je isključen iz priključka za dovod vode.
- ✓ Uređaju se može slobodno pristupiti.
- ✓ [Ladica za deterđent je uklonjena.→30](#)
- ✓ Ploča je uklonjena.
- ✓ [Vrata su uklonjena.→32](#)
- ✓ [Donji poklopac je uklonjen.→40](#)

4.7.1 Uklanjanje brtve vrata

1. Otpustite zadržni element na svjetlu bubnja.

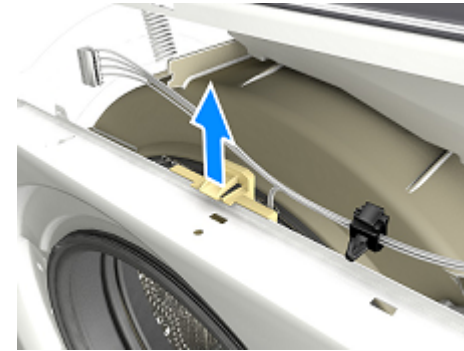

2.

| | |
|---|---|
|  | POZOR! Opasnost od oštećene površine! Površina uređaja može se izgrebati upotrebom pogrešnog alata. ▶ Koristite samo plastični alat za zamjenu zateznog prstena. |
|---|---|

Uklonite zatezni prsten s brtve s pomoću plastičnog alata.

3. Otpustite brtvu vrata s prednje ploče.
4. Otpustite priključak kabela s brave vrata.

5. Otpustite vijke naznačenim redoslijedom.



6. Uklonite prednju ploču.

7. Odvojite sve crijevne priključke.

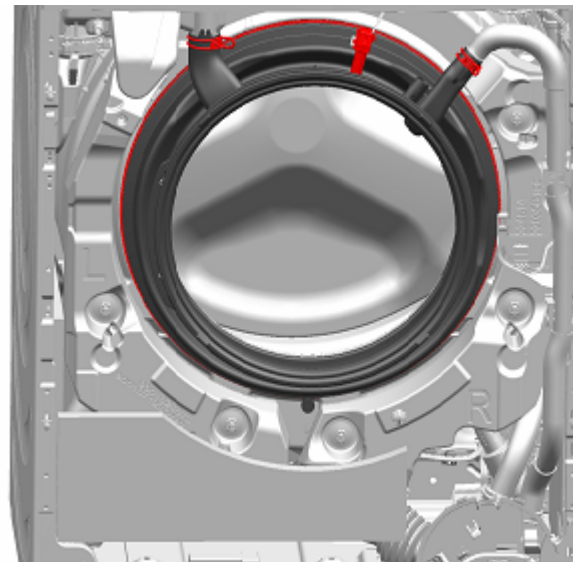





8. Uklonite brtvu vrata.

4.7.2 Postavljanje brtve vrata

- ▶ Postavite obratnim redoslijedom.

4.8 Zamjena brave vrata

Kao proizvođač, obvezni smo pružiti potrošačima rezervne dijelove za bravu vrata, uključujući upute za popravak u skladu s Direktivom (EU) 2019/2023. Međutim, želimo naglasiti da nakon zamjene brave vrata kvalificirani elektrotehničar mora provesti elektrotehnički sigurnosni test prije puštanja uređaja u rad. Ta osoba mora biti potvrđeno kvalificirana u skladu s nacionalnim zakonima, propisima i normama.

| | |
|--|---|
|  | ⚠️ OPASNOST Opasnost od strujnog udara zbog dijelova koji provode struju! U slučaju nepravilnog popravka može doći do opasnosti za život od strujnog udara <ul style="list-style-type: none">▶ Električne dijelove mora popraviti kvalificirani električar.▶ Nakon popravka provedite sigurnosni test u skladu s VDE 0701 ili nacionalnim propisima. |
|  | ⚠️ OPREZ Oštri rubovi kućišta! Porezotine <ul style="list-style-type: none">▶ Nosite zaštitne rukavice. |
|  | ⚠️ UPOZORENJE Isklizavanje nagnutih uređaja! Puknuća kostiju / ozljede od prignječenja <ul style="list-style-type: none">▶ Osigurajte uređaje od isklizavanja. |
|  | ⚠️ OPREZ Opasnost od padanja dijelova zbog otpuštenih vijaka! Ozljeda od dijelova koji padaju. <ul style="list-style-type: none">▶ Osigurajte sastavne dijelove od pada. |
|  | ⚠️ POZOR! Opasnost od padanja dijelova zbog otpuštenih vijaka! Oštećenje drugih dijelova uređaja ili objekta klijenta, npr. poda. <ul style="list-style-type: none">▶ Osigurajte sastavne dijelove od pada. |

Zahtjev:

- ✔ Uređaj je isključen iz napajanja.
- ✔ Uređaj je isključen iz priključka za dovod vode.

- ✔ Uređaju se može slobodno pristupiti.
- ✔ Ploča namještaja je uklonjena.
- ✔ Ploča je uklonjena.
- ✔ [Vrata su uklonjena. → 32](#)
- ✔ Zatezni prsten je uklonjen.
- ✔ Prednja ploča je uklonjena.
- ✔ Brtva vrata je uklonjena.

4.8.1 Uklanjanje brave vrata

1. Iskopčajte priključak brave vrata.
2. Otpustite bravu vrata.



3. Uklonite bravu vrata.

4.8.2 Postavljanje brave vrata

Brava vrata mora biti u odgovarajućem položaju kako bi se osigurala funkcija otvaranja vrata uređaja za slučaj nužde.

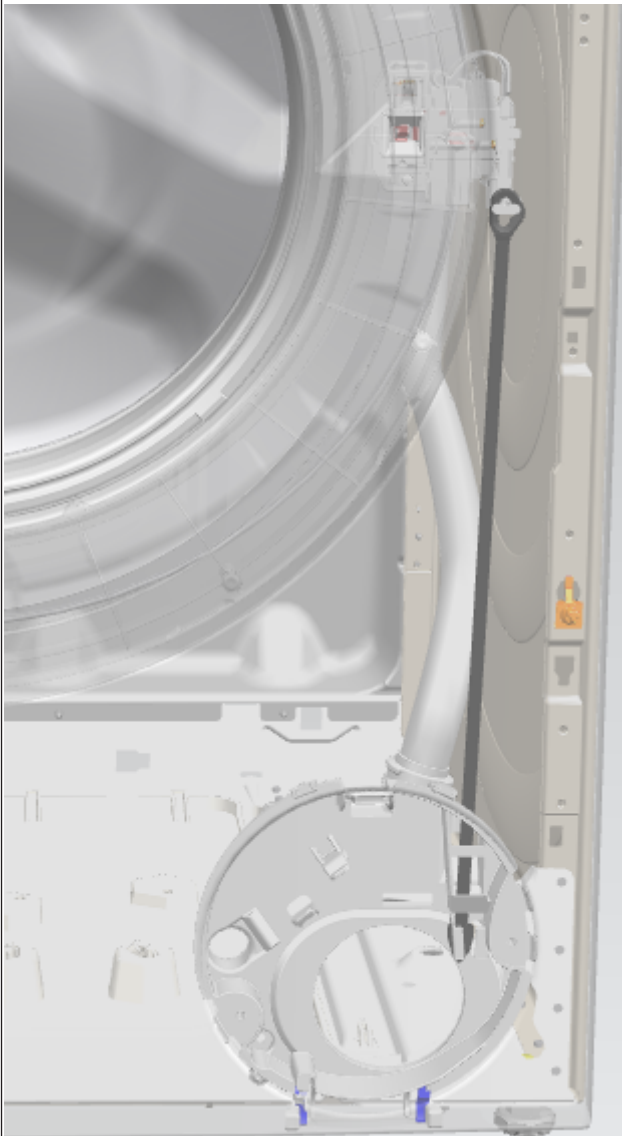

- ▶ Postavite obratnim redoslijedom.

4.9 Zamjena svjetla bubnja



⚠️ OPREZ

Oštri rubovi kućišta!

Porezotine

- ▶ Nosite zaštitne rukavice.



⚠️ UPOZORENJE

Isklizavanje nagnutih uređaja!

Puknuća kostiju / ozljede od prignječenja

- ▶ Osigurajte uređaje od isklizavanja.



⚠️ OPREZ

Opasnost od padanja dijelova zbog otpuštenih vijaka!

Ozljeda od dijelova koji padaju.

- ▶ Osigurajte sastavne dijelove od pada.



POZOR!

Opasnost od padanja dijelova zbog otpuštenih vijaka!

Oštećenje drugih dijelova uređaja ili objekta klijenta, npr. poda.

- ▶ Osigurajte sastavne dijelove od pada.

Zahtjev:

- ✔ Uređaj je isključen iz napajanja.
- ✔ Uređaj je isključen iz priključka za dovod vode.
- ✔ Uređaju se može slobodno pristupiti.
- ✔ [Ladica za deterdžent je uklonjena.→30](#)
- ✔ Ploča je uklonjena.

4.9.1 Uklanjanje svjetla bubnja

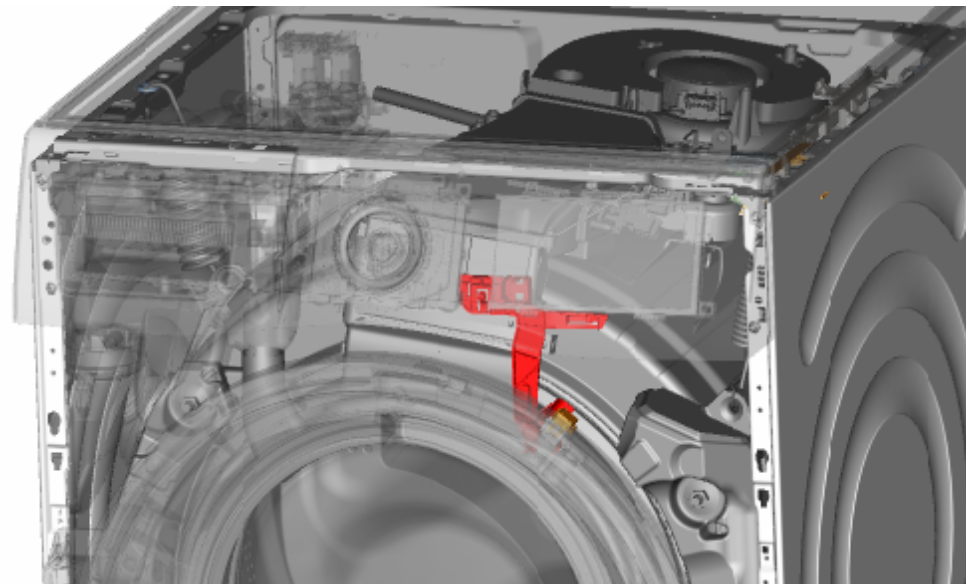

1. Izvucite držač svjetla bubnja iz uređaja.
2. Odvojite električne priključke.
3. Uklonite svjetlo bubnja s držača svjetla bubnja.

4.9.2 Postavljanje svjetla bubnja

- ▶ Postavite obratnim redoslijedom.

4.10 Zamjena donjeg poklopca



Sl. 1: Poklopac donje grupe

Zahtjev:

- ✔ Uređaj je isključen iz napajanja.
- ✔ Uređaj je isključen iz priključka za dovod vode.
- ✔ Ploča namještaja je uklonjena.

4.10.1 Uklanjanje donjeg poklopca

Zahtjev:

- ✔ Uređaj je isključen iz napajanja.
 - ✔ Uređaj je isključen iz priključka za dovod vode.
1. Uklonite donji poklopac.

2. Odvojite crijevo od držača.

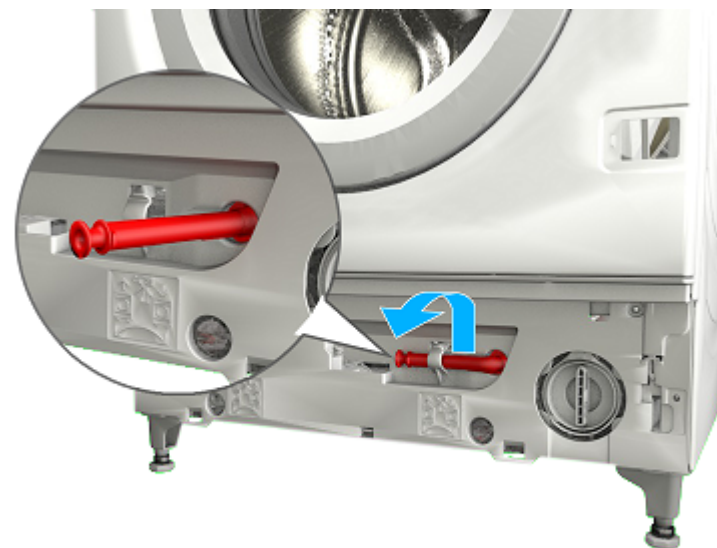

Popravak

3. 1. Odvijte vijak (1).
2. Pritisnite zadržnu točku i uklonite prema dolje (2).

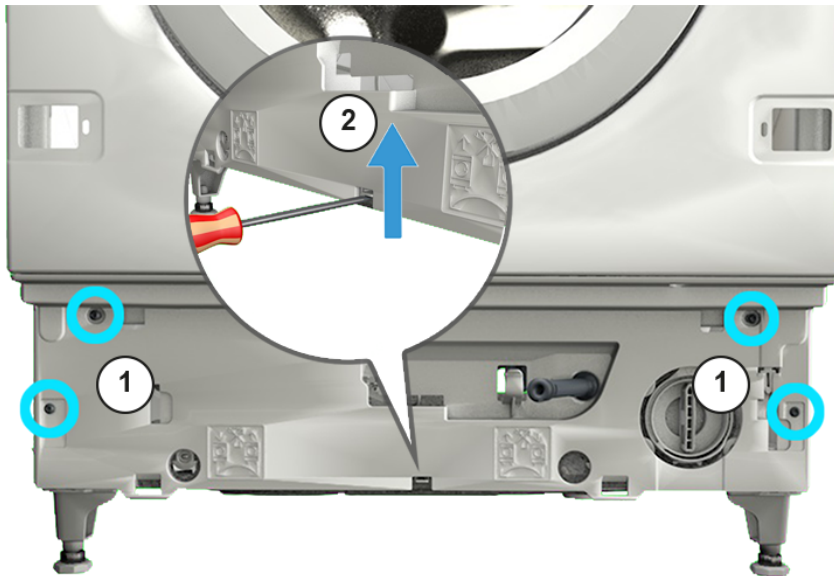

4. Gurnite poklopac donje grupe i uklonite prema naprijed.

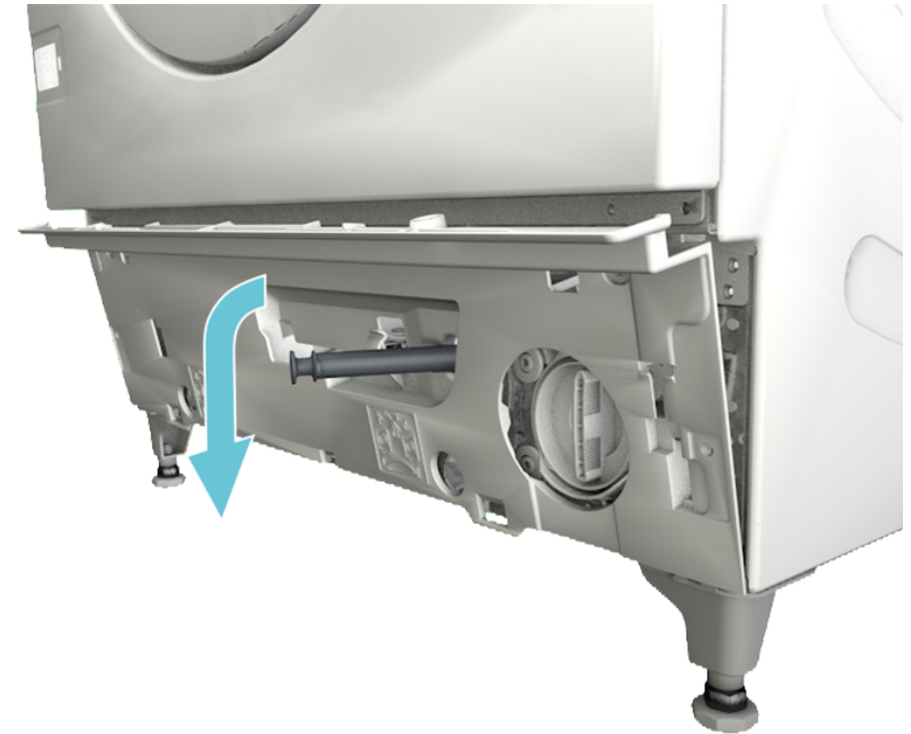

5. Izvucite crijevo iz poklopca.

4.10.2 Postavljanje poklopca

- Postavite obratnim redoslijedom.

4.11 Zamjena prednje ploče



⚠ OPREZ

Oštri rubovi kućišta!

Porezotine

- ▶ Nosite zaštitne rukavice.

Zahtjev:

- ✔ Uređaj je isključen iz napajanja.
- ✔ Uređaj je isključen iz priključka za dovod vode.
- ✔ Uređaju se može slobodno pristupiti.
- ✔ [Ladica za deterđent je uklonjena. →30](#)
- ✔ Ploča namještaja je uklonjena.
- ✔ [Vrata su uklonjena. →32](#)
- ✔ Brtva vrata je uklonjena.

4.11.1 Uklanjanje prednje ploče

1. Otpustite zadržni element na svjetlu bubnja.

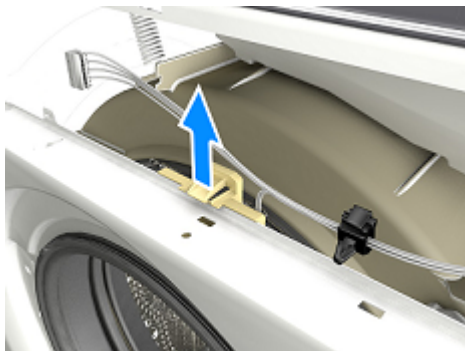

2.



⚠ OPREZ

Opasnost od padanja dijelova zbog otpuštenih vijaka!

Ozljeda od dijelova koji padaju.

- ▶ Osigurajte sastavne dijelove od pada.



POZORI!

Opasnost od padanja dijelova zbog otpuštenih vijaka!

Oštećenje drugih dijelova uređaja ili objekta klijenta, npr. poda.

- ▶ Osigurajte sastavne dijelove od pada.

Otpustite vijke naznačenim redoslijedom.







3. Uklonite prednju ploču.

4.11.2 Postavljanje prednje ploče

- ▶ Postavite obratnim redoslijedom.

Poznámky k opravě - Pračka

| | | | |
|--|-----------|--|--|
|  O tomto dokumentu | 45 | | |
| 1.1 Důležité informace | 45 | | |
| 1.1.1 Účel | 45 | | |
| 1.2 Vysvětlení symbolů | 45 | | |
| 1.2.1 Úroveň nebezpečí | 45 | | |
| 1.2.2 Symboly nebezpečí | 45 | | |
| 1.2.3 Struktura výstrah | 46 | | |
| 1.2.4 Obecné symboly | 46 | | |
|  Bezpečnost | 47 | | |
| 2.1 Všeobecné bezpečnostní pokyny | 47 | | |
| 2.1.1 Všechny domácí spotřebiče | 47 | | |
|  Nástroje a pomůcky | 48 | | |
|  Oprava | 49 | | |
| 4.1 Výměna panelu obložení | 49 | | |
| 4.1.1 Sejmutí panelu obložení | 49 | | |
| 4.1.2 Montáž panelu obložení | 50 | | |
| 4.2 Výměna zásuvky na prací prostředek | 51 | | |
| 4.2.1 Vyjmutí zásuvky na prací prostředek | 51 | | |
| 4.2.2 Montáž zásuvky na prací prostředek | 51 | | |
| 4.3 Výměna madla zásuvky na prací prostředek | 52 | | |
| 4.3.1 Odstranění madla zásuvky na prací prostředek | 52 | | |
| 4.3.2 Montáž madla zásuvky na prací prostředek | 52 | | |
| 4.4 Výměna dvířek | 53 | | |
| 4.4.1 Vyjmutí dvířek | 53 | | |
| 4.4.2 Montáž dvířek | 53 | | |
| 4.5 Výměna součástí dvířek | 54 | | |
| 4.5.1 Odstranění součástí dvířek | 54 | | |
| 4.5.2 Montáž součástí dvířek | 54 | | |
| 4.6 Výměna závěsu dvířek | 55 | | |
| 4.6.1 Odstranění závěsu dvířek | 55 | | |
| 4.6.2 Montáž závěsu dvířek | 55 | | |
| 4.7 Výměna těsnění dvířek | 56 | | |
| 4.7.1 Vyjmutí těsnění dvířek | 56 | | |
| 4.7.2 Montáž těsnění dvířek | 57 | | |
| 4.8 Výměna pojistky dvířek | 58 | | |
| 4.8.1 Odstranění pojistky dvířek | 58 | | |
| 4.8.2 Montáž pojistky dvířek | 59 | | |
| 4.9 Výměna osvětlení bubnu | 60 | | |
| 4.9.1 Odstranění osvětlení bubnu | 60 | | |
| 4.9.2 Montáž osvětlení bubnu | 60 | | |
| 4.10 Výměna spodního krytu | 61 | | |
| 4.10.1 Odstranění spodního krytu | 61 | | |
| 4.10.2 Montáž krytu | 62 | | |
| 4.11 Výměna předního panelu | 63 | | |
| 4.11.1 Sejmutí předního panelu | 63 | | |
| 4.11.2 Montáž předního panelu | 64 | | |

i O tomto dokumentu

1.1 Důležité informace

1.1.1 Účel

Tyto pokyny k opravě pomáhají spotřebiteli při vlastnoruční opravě spotřebičů v souladu s platnými předpisy o ekodesignu (platnými k 03/2021).



Obsahují informace o výměně některých náhradních dílů včetně příslušných výstrah a nebezpečí.

V případě dotazů se obraťte na náš zákaznický servis. Za škody ručíme pouze v případě, že budou správně dodrženy pokyny k opravě.

1.2 Vysvětlení symbolů

1.2.1 Úroveň nebezpečí

Jednotlivé úrovně výstrah se skládají ze symbolu a signálního slova. Signální slova uvádějí závažnost nebezpečí.





| Úroveň výstrahy | Význam |
|--|--|
|  NEBEZPEČÍ | Nedodržení výstražného upozornění způsobí smrt nebo vážná zranění. |
|  VÝSTRAHA | Nedodržení výstražného upozornění může způsobit smrt nebo vážná zranění. |
|  POZOR | Nedodržení výstražného upozornění může způsobit lehká zranění. |
| POZOR! | Nedodržení výstražného upozornění může způsobit škody na majetku. |

Tabulka 1: Úroveň nebezpečí



1.2.2 Symboly nebezpečí

Symboly nebezpečí jsou symbolická znázornění určující druh nebezpečí.

V tomto dokumentu jsou použity následující symboly nebezpečí:

| Symbol nebezpečí | Význam |
|---|---|
|  | Obecné výstražné upozornění |
|  | Nebezpečí vycházející z elektrického napětí |
|  | Nebezpečí výbuchu |
|  | Nebezpečí pořezání |
|  | Nebezpečí rozdrcení |



O tomto dokumentu

| Symbol nebezpečí | Význam |
|--|---|
|  | Nebezpečí spojené s horkými povrchy |
|  | Nebezpečí vycházející ze silného elektromagnetického pole |
|  | Nebezpečí z neionizujícího záření |

Tabulka 2: Symboly nebezpečí

1.2.3 Struktura výstrah

Výstrahy použité v tomto dokumentu mají standardizovaný vzhled a strukturu.



| | |
|--|--|
|  | <div style="background-color: red; color: white; padding: 2px; text-align: center;"> NEBEZPEČÍ</div> <p>Typ a zdroj nebezpečí! Možné důsledky nedodržení výstražného upozornění.</p> <ul style="list-style-type: none"> ▶ Opatření a zákazy eliminující nebezpečí. |
|--|--|





Následující příklad ukazuje výstrahu, která varuje před zásahem elektrickým proudem při dotyku dílů pod proudem. Je uvedeno opatření pro zabránění rizika.

| | |
|---|--|
|  | <div style="background-color: red; color: white; padding: 2px; text-align: center;"> NEBEZPEČÍ</div> <p>Nebezpečí úrazu elektrickým proudem při dotyku dílů pod proudem! Usmrcení elektrickým proudem</p> <ul style="list-style-type: none"> ▶ Odpojte spotřebič od přívodu elektrického proudu alespoň 60 sekund před zahájením opravy. |
|---|--|

1.2.4 Obecné symboly

V tomto dokumentu jsou použity následující obecné symboly:

| Obecný symbol | Význam |
|--|--|
|  | Uvedení zvláštního tipu (text nebo grafické vyjádření) |
|  | Uvedení jednoduchého tipu (pouze text) |
|  | Uvedení odkazu k videonávodu |

| Obecný symbol | Význam |
|---|--|
|  | Uvedení požadovaných nástrojů |
|  | Uvedení požadovaných podmínek |
|  | Uvedení podmínky (když, pak atd.) |
|  | Uvedení výsledku |
| [Start] | Uvedení klávesy nebo tlačítka |
| [00123456] | Uvedení čísla materiálu |
| Status | Uvedení zobrazeného textu / okna (na ukazateli spotřebiče) |

Tabulka 3: Obecné symboly

2.1 Všeobecné bezpečnostní pokyny

2.1.1 Všechny domácí spotřebiče

Nebezpečí úrazu elektrickým proudem při dotyku dílů pod proudem!

- Chyby při opravě elektrických součástí mohou vést k úrazu elektrickým proudem!
- Odpojte spotřebič ze sítě alespoň 60 sekund před zahájením prací.
- Po opravě nechte provést bezpečnostní zkoušku podle VDE 0701 nebo specifických předpisů dané země.

Nebezpečí poranění o ostré hrany!

- Používejte ochranné rukavice.

Nebezpečí rozdrčení během opravy, údržby, odstranění závad a servisu těžkými a pohyblivými součástmi

- Používejte bezpečnostní obuv.
- Zajistěte těžké součásti před pádem.
- Nesahejte na pohyblivé součásti.







Nebezpečí z hlediska bezpečnosti / funkce spotřebiče!





- Používejte pouze originální náhradní díly.

Nebezpečí poškození elektrostaticky citlivých součástí (elektrostatický výboj)!

- Nedotýkejte se modulů, včetně přípojek a vodičů.

Nástroje a pomůcky

| Označení | Detaily | Snímky |
|--|---|--|
| Pomocný nástroj [15000155] | Nástroj pro uvolnění plastových dílů |  |
| Šroubovák torx T20 s otvorem [00340764] | 100 mm, pro šrouby s pojistným kolíkem |  |
| Momentový klíč [15000441] | Momentový klíč 20–100 Nm | |
| Plochý šroubovák [00340854] | Čepel 3,5 mm x 0,6 mm x 100 mm, ochranná izolace 1000 V AC |  |
| Plochý šroubovák [00340855] | Čepel 5,5 mm x 1,0 mm x 125 mm, ochranná izolace 1 000 V AC |  |
| Jehlové kleště, zahnuté [00341269] | Délka 200 mm |  |
| Boční štípací kleště [00342182] | Délka: 200 mm |  |

| Označení | Detaily | Snímky |
|----------------------------------|---------------------------|---|
| Maticový klíč [00340811] | Velikost klíče 10°mm, M6 |  |
| Combination wrench [00340814] | Velikost klíče 13°mm, M8 |  |
| Maticový klíč [00340817] | Velikost klíče 17 mm, M10 |  |
| Maticový klíč [15000459] | Velikost klíče 16°mm, M10 |  |

4.1 Výměna panelu obložení



POZOR

Ostré hrany skříně!
Nebezpečí řezných poranění
▶ Používejte ochranné rukavice.



VÝSTRAHA

Sklouznutí nakloněných spotřebičů!
Zlomeniny / poranění rozdrčením
▶ Zajistěte spotřebiče proti sklouznutí.



POZOR





Nebezpečí padajících dílů kvůli uvolněným šroubům!
Poranění padajícími díly.
▶ Zajistěte jednotlivé součásti před pádem.



POZOR!

Nebezpečí padajících dílů kvůli uvolněným šroubům!
Poškození jiných částí spotřebiče nebo prvků domácnosti zákazníka, např. podlahy.
▶ Zajistěte jednotlivé součásti před pádem.

Požadavek:

-  Spotřebič je odpojený od přívodu elektrické energie.
-  Spotřebič je odpojený od přívodu vody.
-  Spotřebič je volně přístupný.
-  [Zásuvka na prací prostředek je vyjmutá. →51](#)

4.1.1 Sejmutí panelu obložení

1. 1. Uvolněte západku (1).
2. 2. Odstraňte kryt (2).

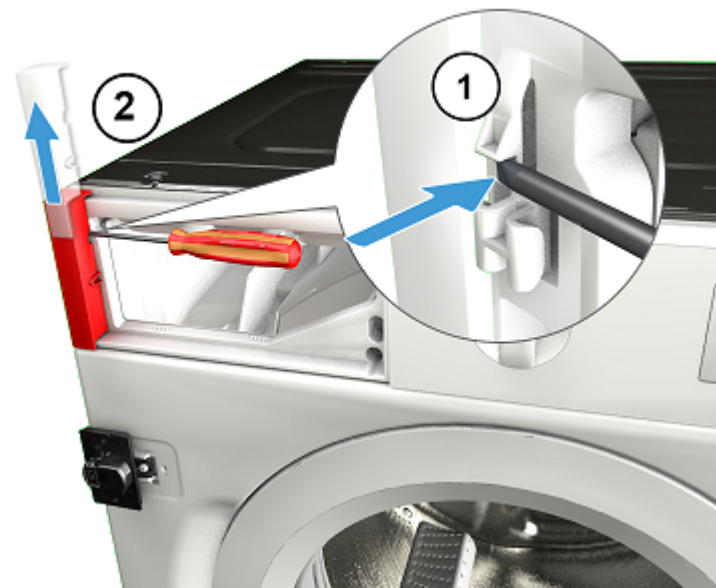

2. Odstraňte šrouby.



3. 1. Uvolněte západky (1, 2).
2. Vytáhněte panel obložení směrem dopředu (3).

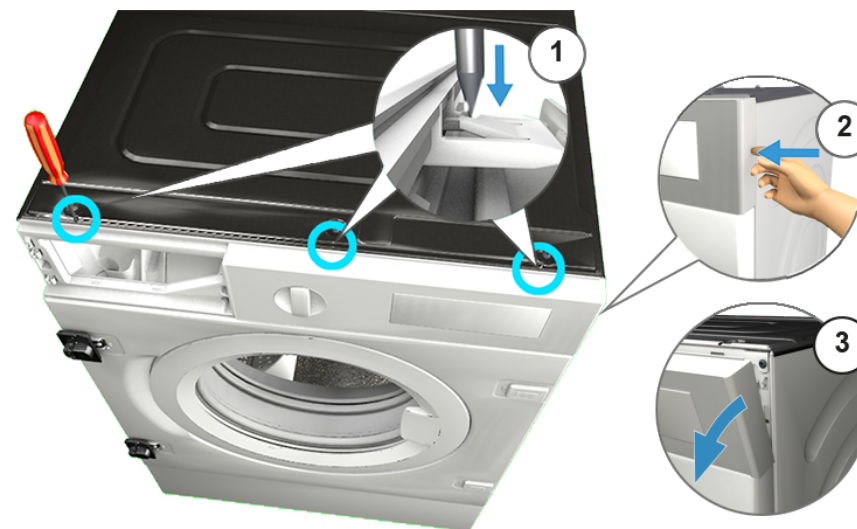

4. Sejměte panel obložení.

4.1.2 Montáž panelu obložení

► Montáž proveďte v opačném sledu.

4.2 Výměna zásuvky na prací prostředek

Požadavek:

- ✔ Spotřebič je odpojený od přívodu elektrické energie.
- ✔ Spotřebič je odpojený od přívodu vody.

4.2.1 Vyjmutí zásuvky na prací prostředek

1. Vytáhněte zásuvku na prací prostředek.
2. 1. Zatlačte na vložku (1).
2. Vyměňte zásuvku na prací prostředek (2).

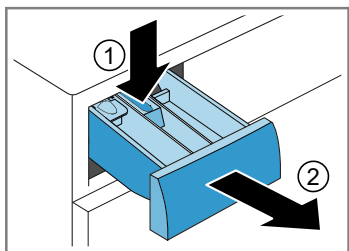

4.2.2 Montáž zásuvky na prací prostředek

- ▶ Montáž provedte v opačném sledu.

4.3 Výměna madla zásuvky na prací prostředek

Požadavek:

- ✔ Spotřebič je odpojený od přívodu elektrické energie.
- ✔ Spotřebič je odpojený od přívodu vody.
- ✔ [Zásuvka na prací prostředek je vyjmutá.→51](#)

4.3.1 Odstranění madla zásuvky na prací prostředek

1. Uvolněte západky.

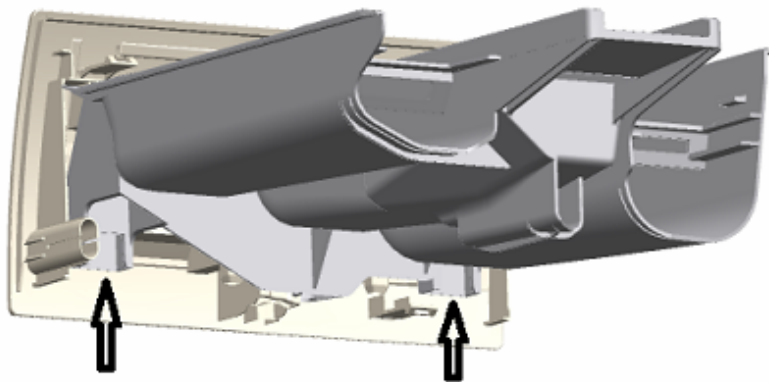

2. Odstraňte madlo zásuvky na prací prostředek.

4.3.2 Montáž madla zásuvky na prací prostředek

- ▶ Montáž provedte v opačném sledu.

4.4 Výměna dvířek



⚠ POZOR

Otevřete prostor se závěsy!

Rozdrcení prstů / zachycení

- ▶ Nesahejte do prostoru se závěsy.
- ▶ Používejte ochranné rukavice.

Požadavek:

- ✔ Spotřebič je odpojený od přívodu elektrické energie.
- ✔ Spotřebič je odpojený od přívodu vody.
- ✔ Dvířka jsou otevřená.
- ✔ Čelní strana nábytku je odstraněná.

4.4.1 Vyjmutí dvířek

1.



POZOR!

Nebezpečí padajících dílů kvůli uvolněným šroubům!

Poškození jiných částí spotřebiče nebo prvků domácnosti zákazníka, např. podlahy.

- ▶ Zajistěte jednotlivé součásti před pádem.



⚠ POZOR

Nebezpečí padajících dílů kvůli uvolněným šroubům!

Poranění padajícími díly.

- ▶ Zajistěte jednotlivé součásti před pádem.

Odstraňte šrouby (1).

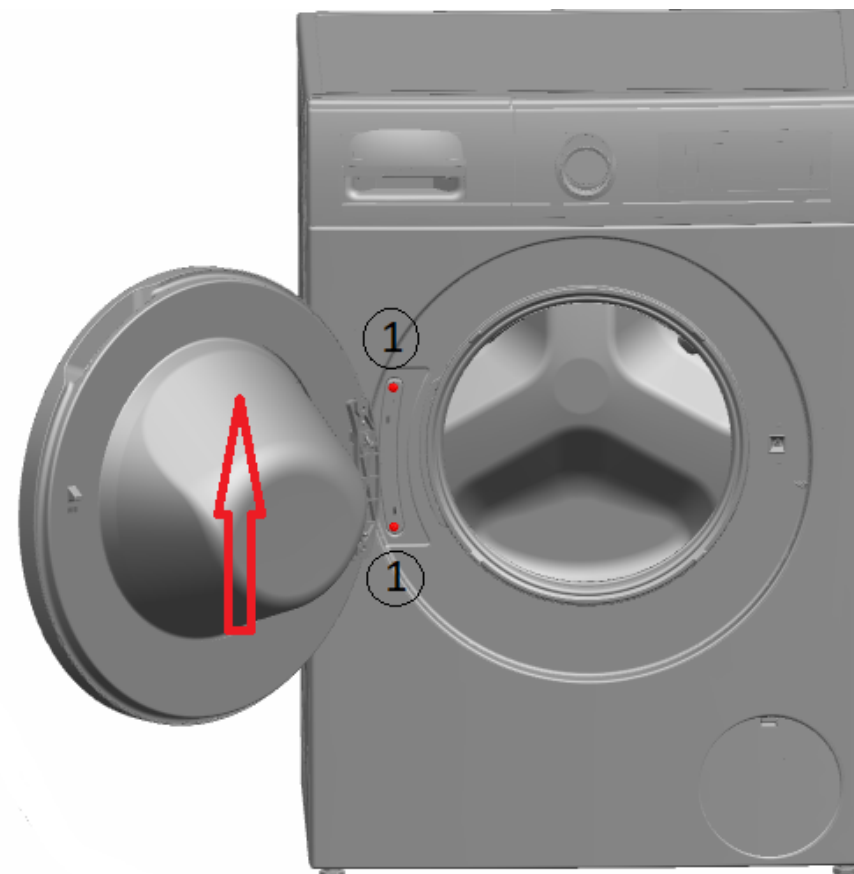

2. Vyjměte dvířka směrem nahoru.

4.4.2 Montáž dvířek

- ▶ Montáž proveďte v opačném sledu.

4.5 Výměna součástí dvířek



POZOR

Otevřete prostor se závěsy!

Rozdrcení prstů / zachycení

- ▶ Nesahejte do prostoru se závěsy.
- ▶ Používejte ochranné rukavice.

Požadavek:

- ✔ Spotřebič je odpojený od přívodu elektrické energie.
- ✔ Spotřebič je odpojený od přívodu vody.
- ✔ Čelní strana nábytku je odstraněná.
- ✔ [Dvířka jsou odstraněná. → 53](#)

4.5.1 Odstranění součástí dvířek

- ▶ Demontujte dvířka zvenku dovnitř.

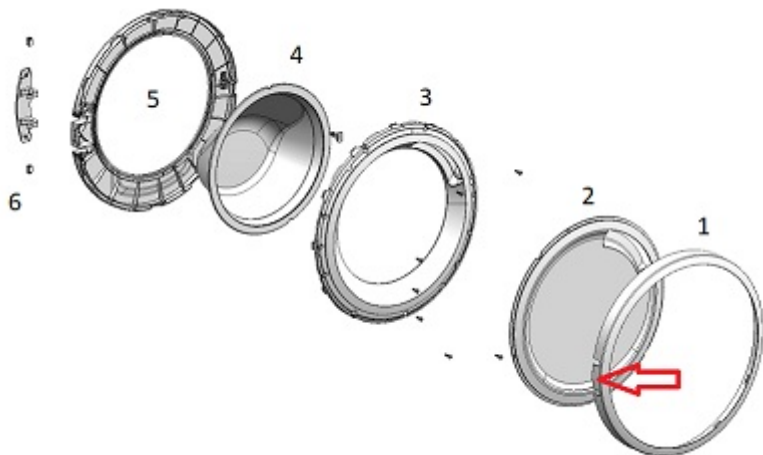

4.5.2 Montáž součástí dvířek

- ▶ Montáž proveďte v opačném sledu.

4.6 Výměna závěsu dvířek



POZOR

Otevřete prostor se závěsy!

Rozdrcení prstů / zachycení

- ▶ Nesahejte do prostoru se závěsy.
- ▶ Používejte ochranné rukavice.

Požadavek:

- ✔ Spotřebič je odpojený od přívodu elektrické energie.
- ✔ Spotřebič je odpojený od přívodu vody.

4.6.1 Odstranění závěsu dvířek

1. Uvolněte dva šrouby.
2. Odstraňte dvířka.
3. Demontujte dvířka zvenku dovnitř.

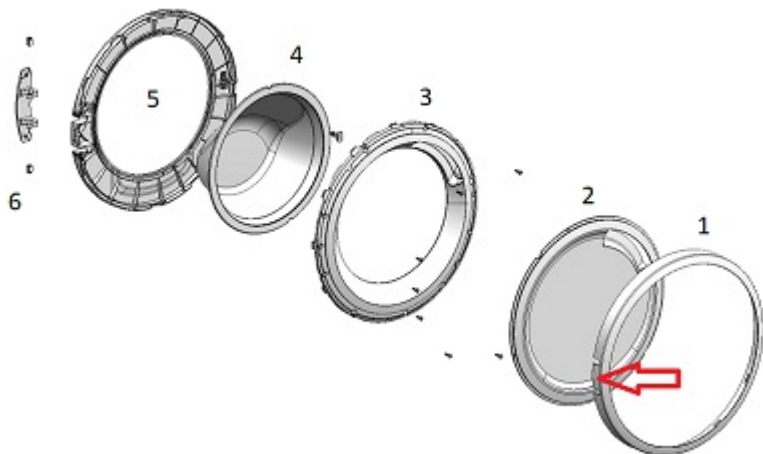



4. Odstraňte závěs dvířek.

4.6.2 Montáž závěsu dvířek

- ▶ Montáž provedte v opačném sledu.

4.7 Výměna těsnění dvířek

| | |
|--|--|
|  | <p>⚠ POZOR</p> <p>Ostré hrany skříně! Nebezpečí řezných poranění</p> <ul style="list-style-type: none"> ▶ Používejte ochranné rukavice. |
|--|--|

| | |
|--|--|
|  | <p>⚠ POZOR</p> <p>Nebezpečí padajících dílů kvůli uvolněným šroubům! Poranění padajícími díly.</p> <ul style="list-style-type: none"> ▶ Zajistěte jednotlivé součásti před pádem. |
|--|--|

| | |
|--|---|
|  | <p>POZOR!</p> <p>Nebezpečí padajících dílů kvůli uvolněným šroubům! Poškození jiných částí spotřebiče nebo prvků domácnosti zákazníka, např. podlahy.</p> <ul style="list-style-type: none"> ▶ Zajistěte jednotlivé součásti před pádem. |
|--|---|

Požadavek:

- ✔ Spotřebič je odpojený od přívodu elektrické energie.
- ✔ Spotřebič je odpojený od přívodu vody.
- ✔ Spotřebič je volně přístupný.
- ✔ [Zásuvka na prací prostředek je vyjmutá.→51](#)
- ✔ Panel obložení je odstraněný.
- ✔ [Dvířka jsou odstraněná.→53](#)
- ✔ [Spodní kryt je odstraněný.→61](#)

4.7.1 Vyjmutí těsnění dvířek

1. Uvolněte pojistku na osvětlení bubny.

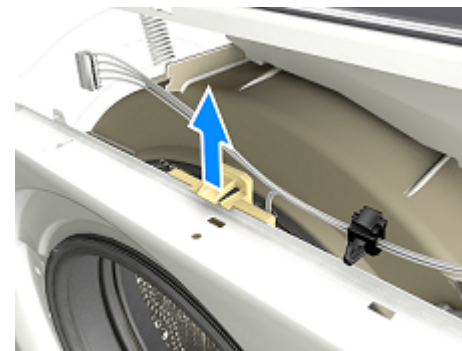

2.

| | |
|---|--|
|  | <p>POZOR!</p> <p>Nebezpečí poškození povrchu! Povrch spotřebiče může být při použití nesprávného náradí poškrábán.</p> <ul style="list-style-type: none"> ▶ K výměně napínacího kroužku používejte pouze plastové náradí. |
|---|--|

Plastovým nářadím vyjměte napínací kroužek z těsnění.

3. Z předního panelu vyjměte těsnění dvířek.
4. Z pojistky dvířek vyjměte konektor kabelu.

5. Uvolněte šrouby v uvedeném pořadí.



6. Sejměte přední panel.

7. Odpojte všechny hadicové spoje.

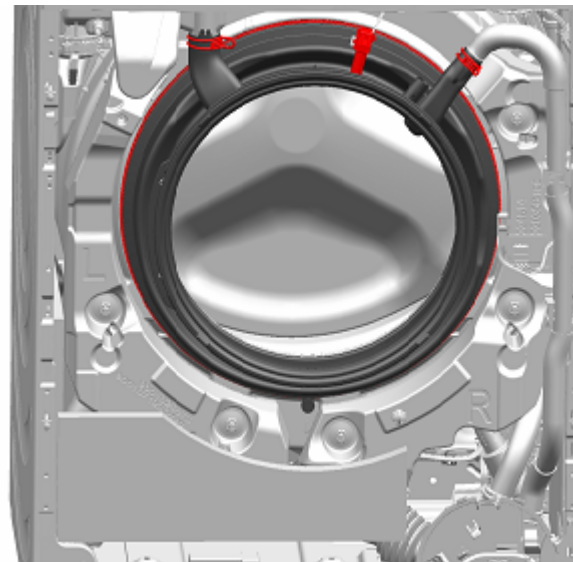

8. Odstraňte těsnění dvířek.

4.7.2 Montáž těsnění dvířek

► Montáž proveďte v opačném sledu.

4.8 Výměna pojistky dvířek

V souladu s nařízením (EU) 2019/2023 jsme coby výrobce povinni poskytnout spotřebitelům náhradní pojistku dvířek včetně návodu k opravě. Upozorňujeme však na to, že po výměně pojistky dvířek je před uvedením zařízení do provozu vyžadována elektrotechnická bezpečnostní zkouška kvalifikovaným elektrikářem. Tato osoba musí být prokazatelně kvalifikovaná podle zákonů, předpisů a norem platných v dané zemi.

| | |
|--|--|
|  | ⚠ NEBEZPEČÍ |
| | <p>Nebezpečí úrazu elektrickým proudem při dotyku dílů pod proudem! V případě neodborné opravy hrozí nebezpečí smrtelného úrazu elektrickým proudem</p> <ul style="list-style-type: none"> ▶ Opravu elektrického zařízení smí provádět jen kvalifikovaný elektrikář. ▶ Po opravě nechte provést bezpečnostní zkoušku podle VDE 0701 nebo specifických předpisů dané země. |

| | |
|--|--|
|  | ⚠ POZOR |
| | <p>Ostré hrany skříně! Nebezpečí řezných poranění</p> <ul style="list-style-type: none"> ▶ Používejte ochranné rukavice. |

| | |
|---|---|
|  | ⚠ VÝSTRAHA |
| | <p>Sklouznutí nakloněných spotřebičů! Zlomeniny / poranění rozdrčením</p> <ul style="list-style-type: none"> ▶ Zajistěte spotřebiče proti sklouznutí. |

| | |
|--|--|
|  | ⚠ POZOR |
| | <p>Nebezpečí padajících dílů kvůli uvolněným šroubům! Poranění padajícími díly.</p> <ul style="list-style-type: none"> ▶ Zajistěte jednotlivé součásti před pádem. |

| | |
|--|--|
|  | POZOR! |
| | <p>Nebezpečí padajících dílů kvůli uvolněným šroubům! Poškození jiných částí spotřebiče nebo prvků domácnosti zákazníka, např. podlahy.</p> <ul style="list-style-type: none"> ▶ Zajistěte jednotlivé součásti před pádem. |

Požadavek:

- ✔ Spotřebič je odpojený od přívodu elektrické energie.

- ✔ Spotřebič je odpojený od přívodu vody.
- ✔ Spotřebič je volně přístupný.
- ✔ Čelní strana nábytku je odstraněná.
- ✔ Panel obložení je odstraněný.
- ✔ [Dvířka jsou odstraněná.→53](#)
- ✔ Napínací kroužek je vyjmutý.
- ✔ Přední panel je odstraněný.
- ✔ Těsnění dvířek je vyjmuté.

4.8.1 Odstranění pojistky dvířek

1. Vytáhněte zástrčku pojistky dvířek.
2. Uvolněte pojistku dvířek.



3. Odstraňte pojistku dvířek.

4.8.2 Montáž pojistky dvířek

Pojistka dvířek musí být ve správné poloze, aby byla zajištěna správná funkce nouzového otvírání dvířek spotřebiče.



- ▶ Montáž provedte v opačném sledu.

4.9 Výměna osvětlení bubnu



POZOR

Ostré hrany skříně!
Nebezpečí řezných poranění
▶ Používejte ochranné rukavice.



VÝSTRAHA

Sklouznutí nakloněných spotřebičů!
Zlomeniny / poranění rozdrčením
▶ Zajistěte spotřebiče proti sklouznutí.



POZOR





Nebezpečí padajících dílů kvůli uvolněným šroubům!
Poranění padajícími díly.
▶ Zajistěte jednotlivé součásti před pádem.



POZOR!

Nebezpečí padajících dílů kvůli uvolněným šroubům!
Poškození jiných částí spotřebiče nebo prvků domácnosti zákazníka, např. podlahy.
▶ Zajistěte jednotlivé součásti před pádem.

Požadavek:

-  Spotřebič je odpojený od přívodu elektrické energie.
-  Spotřebič je odpojený od přívodu vody.
-  Spotřebič je volně přístupný.
-  [Zásuvka na prací prostředek je vyjmutá. →51](#)
-  Panel obložení je odstraněný.

4.9.1 Odstranění osvětlení bubnu

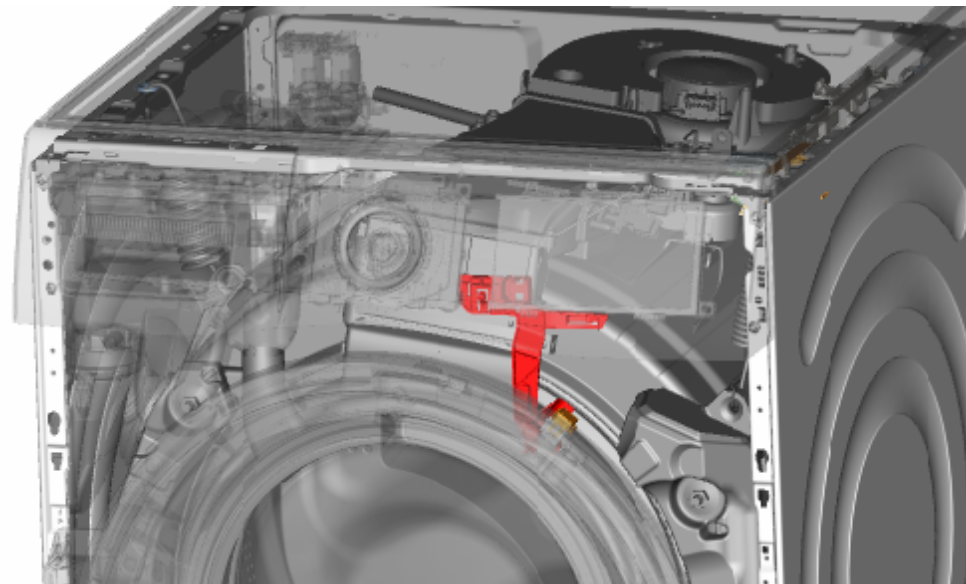

1. Ze spotřebiče vytáhněte držák osvětlení bubnu.
2. Odpojte elektrické připojení.
3. Vyjměte osvětlení bubnu z držáku osvětlení.

4.9.2 Montáž osvětlení bubnu

- ▶ Montáž proveďte v opačném sledu.

4.10 Výměna spodního krytu



Obr. 1: Kryt spodního modulu

Požadavek:

- ✔ Spotřebič je odpojený od přívodu elektrické energie.
- ✔ Spotřebič je odpojený od přívodu vody.
- ✔ Čelní strana nábytku je odstraněná.

4.10.1 Odstranění spodního krytu

Požadavek:

- ✔ Spotřebič je odpojený od přívodu elektrické energie.
 - ✔ Spotřebič je odpojený od přívodu vody.
1. Odstraňte spodní kryt.

2. Odpojte hadici od držáku.

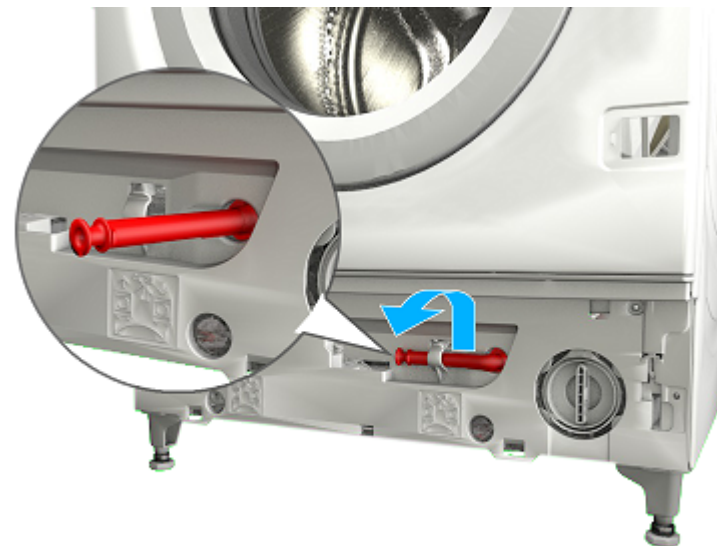

3. 1. Vyšroubujte šrouby (1).
2. Stiskněte zajišťovací kolík a sejměte jej směrem dolů (2).

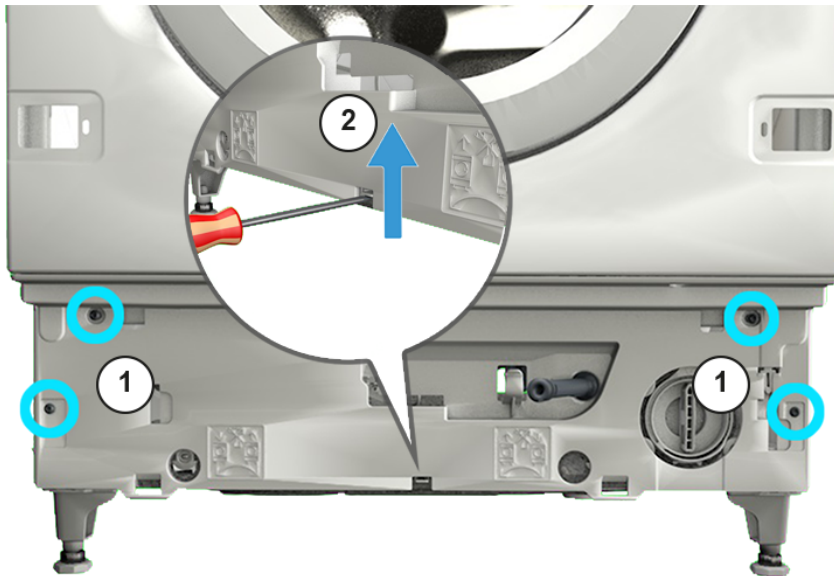

4. Zatáhněte kryt spodního modulu směrem dopředu.



5. Z krytu vytáhněte hadici.

4.10.2 Montáž krytu

- Montáž proveďte v opačném sledu.

4.11 Výměna předního panelu



POZOR

Ostré hrany skříně!

- Nebezpečí řezných poranění
- ▶ Používejte ochranné rukavice.

Požadavek:

- ✔ Spotřebič je odpojený od přívodu elektrické energie.
- ✔ Spotřebič je odpojený od přívodu vody.
- ✔ Spotřebič je volně přístupný.
- ✔ Zásuvka na prací prostředek je vyjmutá. → 51
- ✔ Čelní strana nábytku je odstraněná.
- ✔ Dvířka jsou odstraněná. → 53
- ✔ Těsnění dvířek je vyjmuté.

4.11.1 Sejmutí předního panelu

1. Uvolněte pojistku na osvětlení bubny.

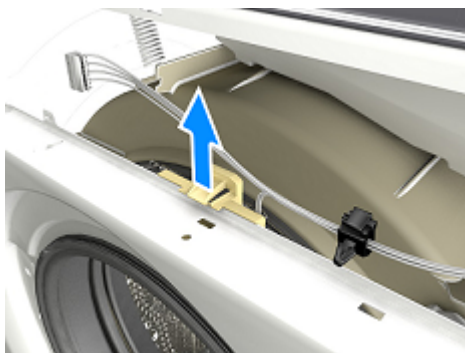

2.



POZOR

Nebezpečí padajících dílů kvůli uvolněným šroubům!

- Poranění padajícími díly.
- ▶ Zajistěte jednotlivé součásti před pádem.



POZOR!

Nebezpečí padajících dílů kvůli uvolněným šroubům!

- Poškození jiných částí spotřebiče nebo prvků domácnosti zákazníka, např. podlahy.
- ▶ Zajistěte jednotlivé součásti před pádem.

Uvolněte šrouby v uvedeném pořadí.







3. Sejměte přední panel.

4.11.2 Montáž předního panelu

► Montáž provedte v opačném sledu.

Tip til reparation - Vaskemaskine

| | | | |
|---|-----------|--|----|
|  Om dette dokument | 66 | 4.8 Udskiftning af dørlås | 79 |
| 1.1 Vigtig information..... | 66 | 4.8.1 Fjernelse af dørlås..... | 79 |
| 1.1.1 Formål..... | 66 | 4.8.2 Montering af dørlås..... | 80 |
| 1.2 Forklaring af symboler | 66 | 4.9 Udskiftning af tromlelyse | 81 |
| 1.2.1 Fareniveauer | 66 | 4.9.1 Fjernelse af tromlelyse..... | 81 |
| 1.2.2 Faresymboler..... | 66 | 4.9.2 Montering af tromlelyse..... | 81 |
| 1.2.3 Advarslernes opbygning | 67 | 4.10 Udskiftning af afdækning fornedet | 82 |
| 1.2.4 Generelle symboler | 67 | 4.10.1 Fjernelse af afdækning fornedet | 82 |
|  Sikkerhed | 68 | 4.10.2 Montering af afdækningen..... | 83 |
| 2.1 Generelle sikkerhedsanvisninger | 68 | 4.11 Udskiftning af frontpanel..... | 84 |
| 2.1.1 Alle husholdningsapparater | 68 | 4.11.1 Fjernelse af frontpanel | 84 |
|  Værktøjer og hjælpemidler | 69 | 4.11.2 Montering af frontpanel | 85 |
|  Reparation | 70 | | |
| 4.1 Udskiftning af betjeningspanel..... | 70 | | |
| 4.1.1 Fjernelse af betjeningspanel | 70 | | |
| 4.1.2 Montering af betjeningspanel | 71 | | |
| 4.2 Udskiftning af sæbeskuffe | 72 | | |
| 4.2.1 Fjernelse af sæbeskuffe | 72 | | |
| 4.2.2 Montering af sæbeskuffe | 72 | | |
| 4.3 Udskiftning af sæbeskuffens håndtag | 73 | | |
| 4.3.1 Fjernelse af sæbeskuffens håndtag..... | 73 | | |
| 4.3.2 Montering af sæbeskuffens håndtag..... | 73 | | |
| 4.4 Udskiftning af dør | 74 | | |
| 4.4.1 Fjernelse af dør..... | 74 | | |
| 4.4.2 Montering af dør | 74 | | |
| 4.5 Udskiftning af dørkomponenter..... | 75 | | |
| 4.5.1 Fjernelse af dørkomponenter | 75 | | |
| 4.5.2 Montering af dørkomponenter | 75 | | |
| 4.6 Udskiftning af dørhængsel | 76 | | |
| 4.6.1 Fjernelse af dørhængsel..... | 76 | | |
| 4.6.2 Montering af dørhængsel..... | 76 | | |
| 4.7 Udskiftning af dørpakning..... | 77 | | |
| 4.7.1 Fjernelse af dørpakning..... | 77 | | |
| 4.7.2 Montering af dørpakning..... | 78 | | |

i Om dette dokument

1.1 Vigtig information

1.1.1 Formål

Disse reparationsanvisninger hjælper kunden til selv at kunne reparere apparater i henhold til den gældende lovgivning om miljøvenligt design (fra 03/2021).





De indeholder information om, hvordan der udskiftes bestemte reservedele, herunder advarsler og risici.

Kontakt kundeservice i tilfælde af spørgsmål. Vi påtager os kun ansvar for skader, hvis reparationsanvisningerne er fuldt korrekt.

1.2 Forklaring af symboler

1.2.1 Fareniveauer

Advarselsniveauerne består af et symbol og et signalford. Signalfordene indikerer farens alvor.





| Advarselsniveau | Betydning |
|---|--|
|  | Manglende overholdelse af advarselsmeddelelsen vil medføre død eller alvorlige kvæstelser. |
|  | Manglende overholdelse af advarselsmeddelelsen kan medføre død eller alvorlige kvæstelser. |
|  | Manglende overholdelse af advarselsmeddelelsen kan medføre mindre kvæstelser. |
|  | Manglende overholdelse af advarselsmeddelelsen kan medføre materiel beskadigelse. |

Tabel 1: Fareniveauer





1.2.2 Faresymboler

Faresymboler er symbolske visninger, der giver en indikation af faretypen.

Der anvendes følgende faresymboler i dette dokument:

| Faresymbol | Betydning |
|---|-----------------------------|
|  | Generel advarselsmeddelelse |
|  | Fare for elektrisk spænding |
|  | Eksplussionsfare |
|  | Fare for at skære sig |

i Om dette dokument

| Faresymbol | Betydning |
|--|-------------------------------------|
|  | Fare for klemning |
|  | Fare pga. varme overflader |
|  | Fare pga. kraftigt magnetfelt |
|  | Fare pga. ikke-ioniserende stråling |

Tabel 2: Faresymboler

1.2.3 Advarslernes opbygning

Advarsler i dette dokument har et standardiseret udseende og en standardiseret opbygning.



| | |
|--|---|
|  | <p>FARE</p> <p>Farens type og kilde! Mulige følger, hvis faren/advarslen ignoreres.</p> <ul style="list-style-type: none"> ▶ Foranstaltninger og forbud for at forhindre faren. |
|--|---|

De følgende eksempler viser en advarsel, der advarer mod elektrisk stød pga. spændingsførende dele. Foranstaltningen til at undgå faren er nævnt.

| | |
|--|---|
|  | <p>FARE</p> <p>Fare for elektrisk stød pga. spændingsførende dele! Død ved elektrisk stød</p> <ul style="list-style-type: none"> ▶ Afbryd apparater fra strømforsyningen i mindst 60 sekunder, før reparationer påbegyndes. |
|--|---|

1.2.4 Generelle symboler

Der anvendes følgende generelle symboler i dette dokument:

| Generelt symbol | Betydning |
|---|--|
|  | Angivelse af et særligt tip (tekst og/eller grafik) |
|  | Angivelse af et simpelt tip (kun tekst) |
|  | Angivelse af et link til en videotutorial |
|  | Angivelse af nødvendige værktøjer |
|  | Angivelse af krævede forudsætninger |
|  | Angivelse af en betingelse (hvis..., så...) |
|  | Angivelse af et resultat |
|  | Angivelse af en tast eller knap |
|  | Angivelse af et materialenummer |
|  | Angivelse af en vist tekst/et vist vindue (i apparatets display) |

Tabel 3: Generelle symboler

2.1 Generelle sikkerhedsanvisninger

2.1.1 Alle husholdningsapparater

Fare for elektrisk stød pga. spændingsførende dele!

- Fejl i forbindelse med reparationer, der involverer elektriske komponenter, kan medføre elektrisk stød!
- Afbryd apparatet fra strømnettet i mindst 60 sekunder, før arbejdet påbegyndes.
- Få efter reparationen udført en sikkerhedstest i henhold til VDE 0701 eller landespecifikke forskrifter.

Fare for tilskadekomst pga. skarpe kanter!

- Brug beskyttelseshandsker.

Fare for klemning i forbindelse med reparation, vedligeholdelse, fejlafhjælpning og service på grund af tunge og bevægelige komponenter

- Brug sikkerhedssko.
- Sørg for at sikre tunge komponenter mod at falde ned.
- Stik kropsdele ind i bevægelige komponenter.







Fare for apparatets sikkerhed/funktion!





- Brug kun originale reservedele.

Fare for beskadigelse af elektrostatisk følsomme komponenter (elektrostatiske afladninger)!

- Berør ikke modulerne, herunder forbindelser og ledningsbaner.

Værktøjer og hjælpemidler

| Betegnelse | Detaljer | Billeder |
|---|--|--|
| Hjælpeværktøj [15000155] | Værktøj til at løsne plastikdele ud |  |
| Skruetrækker Torx T20 med borehul [00340764] | 100 mm for skruer med sikringsstift |  |
| Momentnøgle [15000441] | Momentnøgle 20 - 100 Nm | |
| Kærviskruestrækker [00340854] | Blad 3,5 mm x 0,6 mm x 100 mm, beskyttelsesisolering 1000 V AC |  |
| Kærviskruestrækker [00340855] | Blad 5,5 mm x 1,0 mm x 125 mm, beskyttelsesisolering 1000 V AC |  |
| Nåletænger, vinklet [00341269] | Længde 200 mm |  |
| Bidetænger [00342182] | Længde: 200 mm |  |

| Betegnelse | Detaljer | Billeder |
|----------------------------------|---|---|
| Fastnøgle [00340811] | Fastnøgle størrelse 10 ^o mm, M6 |  |
| Combination wrench [00340814] | Fastnøgle størrelse 13 ^o mm, M8 |  |
| Fastnøgle [00340817] | Fastnøgle størrelse 17 mm, M10 |  |
| Fastnøgle [15000459] | Fastnøgle størrelse 16 ^o mm, M10 |  |

4.1 Udskiftning af betjeningspanel

| | |
|--|--|
|  | ⚠ PAS PÅ! Skarpe huskanter! Snitlæsioner ▶ Brug beskyttelseshandsker. |
|--|--|

| | |
|--|---|
|  | ⚠ ADVARSEL Apparater på skrå kan glide! Knoglebrud/klemeskader ▶ Sørg for at sikre apparater mod at glide. |
|--|---|

| | |
|--|--|
|  | ⚠ PAS PÅ! Fare for nedfaldende dele pga. løsnede skruer! Personskade pga. nedfaldende dele. ▶ Sørg for at sikre komponenten mod at falde ned. |
|--|--|

| | |
|--|--|
|  | BEMÆRK! Fare for nedfaldende dele pga. løsnede skruer! Beskadigelse af andre apparatdele eller kundens hjem, f.eks. gulvet. ▶ Sørg for at sikre komponenten mod at falde ned. |
|--|--|

Preindstilling:

- ✔ Apparatet er afbrudt fra strømforsyningen.
- ✔ Apparatet er afbrudt fra vandforsyningen.
- ✔ Der er fri adgang til apparaterne.
- ✔ [Sæbeskuffen er fjernet. →72](#)

4.1.1 Fjernelse af betjeningspanel

1. Frigør låseelementet (1).
2. Fjern afdækningen (2).

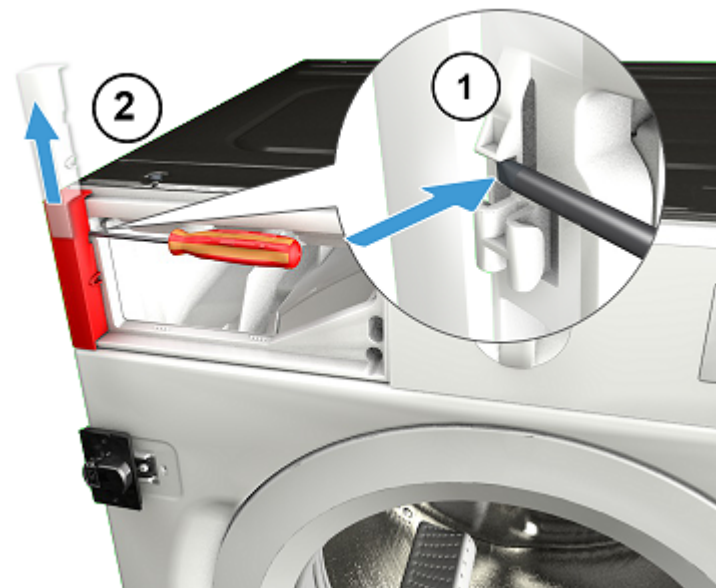

Reparation

2. Fjern skrueerne.



3. 1. Frigør låseelementerne (1, 2).
2. Træk betjeningspanelet af ned mod fronten (3).

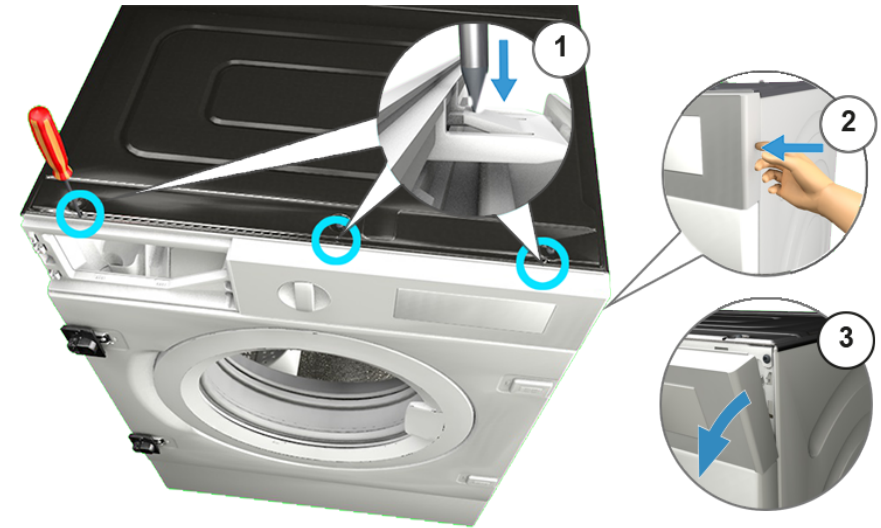

4. Fjern betjeningspanelet.

4.1.2 Montering af betjeningspanel

► Montér i omvendt rækkefølge.

4.2 Udskiftning af sæbeskuffe

Preindstilling:

- ✓ Apparatet er afbrudt fra strømforsyningen.
- ✓ Apparatet er afbrudt fra vandforsyningen.

4.2.1 Fjernelse af sæbeskuffe

1. Træk sæbeskuffen ud.
2. 1. Tryk ned på indsatsen (1).
2. Fjern sæbeskuffen (2).

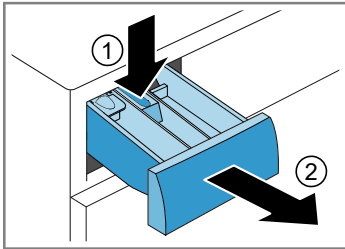

4.2.2 Montering af sæbeskuffe

- ▶ Montér i omvendt rækkefølge.

4.3 Udskiftning af sæbeskuffens håndtag

Preindstilling:

- ✓ Apparatet er afbrudt fra strømforsyningen.
- ✓ Apparatet er afbrudt fra vandforsyningen.
- ✓ [Sæbeskuffen er fjernet.](#) → 72

4.3.1 Fjernelse af sæbeskuffens håndtag

1. Frigør låseelementerne.

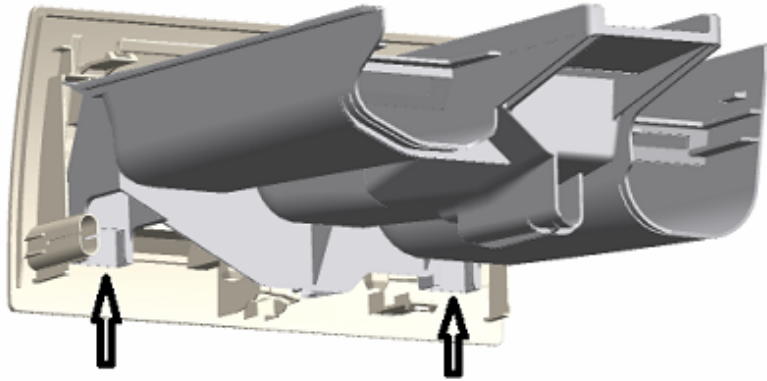

2. Fjern sæbeskuffens håndtag.

4.3.2 Montering af sæbeskuffens håndtag

- ▶ Montér i omvendt rækkefølge.

4.4 Udskiftning af dør



⚠ PAS PÅ!

Åbent hængselområde!

Fingre kan blive klemt/sætte sig fast

- ▶ Grib ikke ind i hængselområdet.
- ▶ Brug beskyttelseshandsker.

Preindstilling:

- ✔ Apparatet er afbrudt fra strømforsyningen.
- ✔ Apparatet er afbrudt fra vandforsyningen.
- ✔ Døren er åben.
- ✔ Møbelpanelet er fjernet.

4.4.1 Fjernelse af dør

1.



BEMÆRK!

Fare for nedfaldende dele pga. løsnede skruer!

Beskadigelse af andre apparatdele eller kundens hjem, f.eks. gulvet.

- ▶ Sørg for at sikre komponenten mod at falde ned.



⚠ PAS PÅ!

Fare for nedfaldende dele pga. løsnede skruer!

Personskade pga. nedfaldende dele.

- ▶ Sørg for at sikre komponenten mod at falde ned.

Fjern skruerne (1).

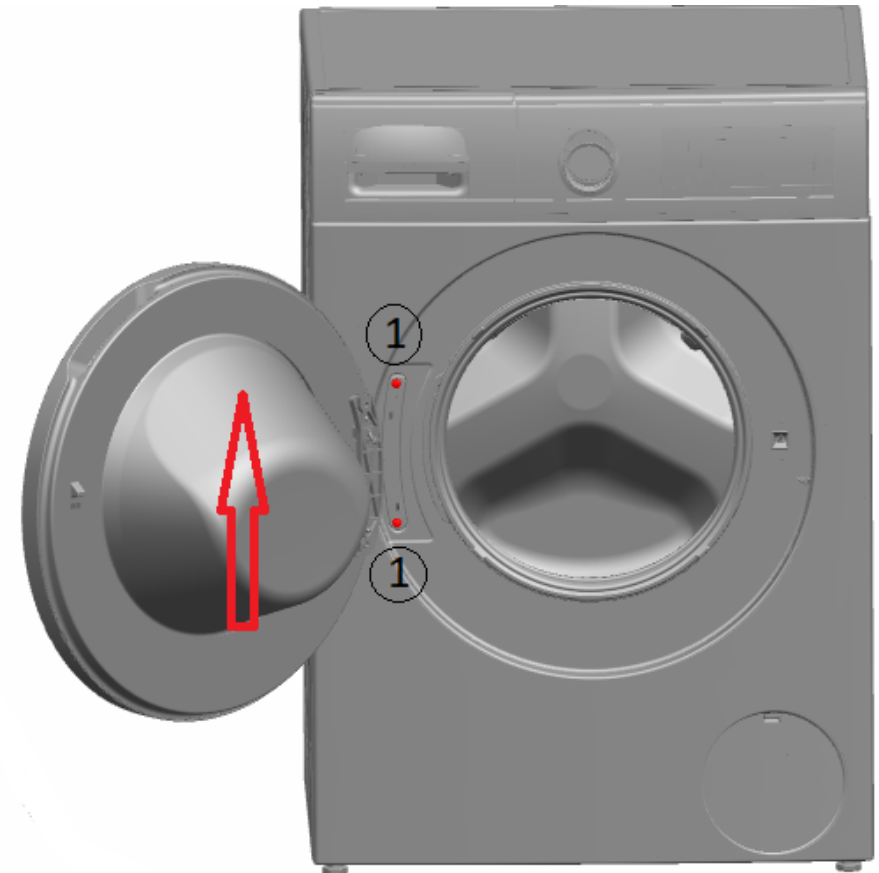

2. Fjern døren opad.

4.4.2 Montering af dør

- ▶ Montér i omvendt rækkefølge.

4.5 Udskiftning af dørkomponenter



⚠ PAS PÅ!

Åbent hængselområde!

Fingre kan blive klemt/sætte sig fast

- ▶ Grib ikke ind i hængselområdet.
- ▶ Brug beskyttelseshandsker.

Preindstilling:

- ✓ Apparatet er afbrudt fra strømforsyningen.
- ✓ Apparatet er afbrudt fra vandforsyningen.
- ✓ Møbelpanelet er fjernet.
- ✓ [Døren er fjernet.](#) →74

4.5.1 Fjernelse af dørkomponenter

- ▶ Skil døren ad udefra og ind.

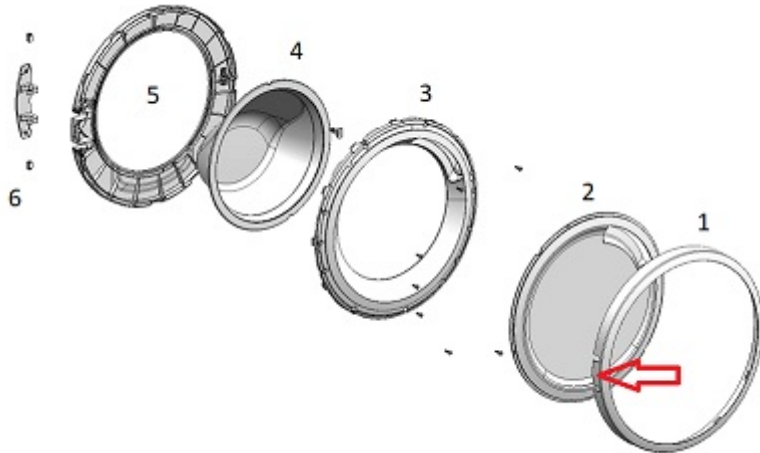

4.5.2 Montering af dørkomponenter

- ▶ Montér i omvendt rækkefølge.

4.6 Udskiftning af dørhængsel



⚠ PAS PÅ!

Åbent hængselområde!

Fingre kan blive klemt/sætte sig fast

- ▶ Grib ikke ind i hængselområdet.
- ▶ Brug beskyttelseshandsker.

Preindstilling:

- ✓ Apparatet er afbrudt fra strømforsyningen.
- ✓ Apparatet er afbrudt fra vandforsyningen.

4.6.1 Fjernelse af dørhængsel

1. Løsn de to skruer.
2. Fjern døren.
3. Skil døren ad udefra og ind.

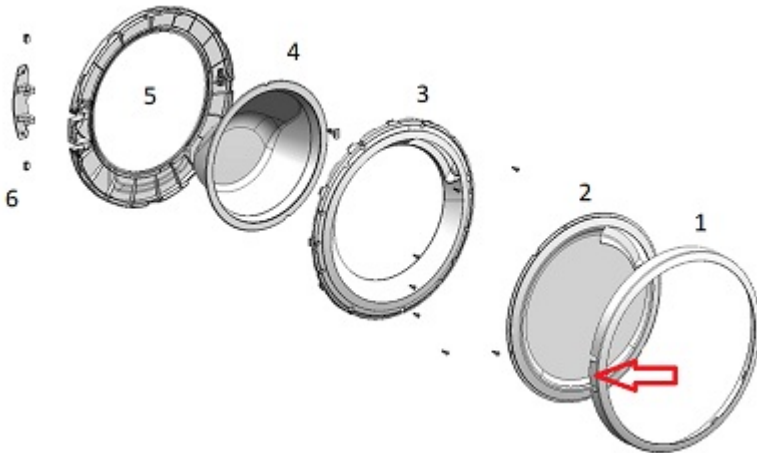



4. Fjern dørhængslet.

4.6.2 Montering af dørhængsel

- ▶ Montér i omvendt rækkefølge.

4.7 Udskiftning af dørpakning

| | |
|--|--|
|  | ⚠ PAS PÅ! Skarpe huskanter! Snitlæsioner ▶ Brug beskyttelseshandsker. |
|--|--|

| | |
|--|--|
|  | ⚠ PAS PÅ! Fare for nedfaldende dele pga. løsnede skruer! Personskade pga. nedfaldende dele. ▶ Sørg for at sikre komponenten mod at falde ned. |
|--|--|

| | |
|--|--|
|  | BEMÆRK! Fare for nedfaldende dele pga. løsnede skruer! Beskadigelse af andre apparatdele eller kundens hjem, f.eks. gulvet. ▶ Sørg for at sikre komponenten mod at falde ned. |
|--|--|

Preindstilling:

- ✓ Apparatet er afbrudt fra strømforsyningen.
- ✓ Apparatet er afbrudt fra vandforsyningen.
- ✓ Der er fri adgang til apparaterne.
- ✓ [Sæbeskuffen er fjernet.→72](#)
- ✓ Betjeningspanelet er fjernet.
- ✓ [Døren er fjernet.→74](#)
- ✓ [Afdækningen forned er fjernet.→82](#)

4.7.1 Fjernelse af dørpakning

1. Løsn holderen på tromlelyset.



2.

| | |
|---|--|
|  | BEMÆRK! Fare for beskadiget overflade! Apparatets overflade kan blive ridset, hvis der bruges forkerte værktøjer. ▶ Brug kun plastikværktøjer til at udskifte spænderingen. |
|---|--|

Fjern spænderingen fra pakningsringen med et plastikværktøj.

3. Frigør dørpakningen fra frontpanelet.
4. Frigør kabelkonnektoren fra dørlåsen.

Reparation

5. Løsn skruerne i den viste rækkefølge.



6. Fjern frontpanelet.

7. Afbryd alle slangeforbindelser.

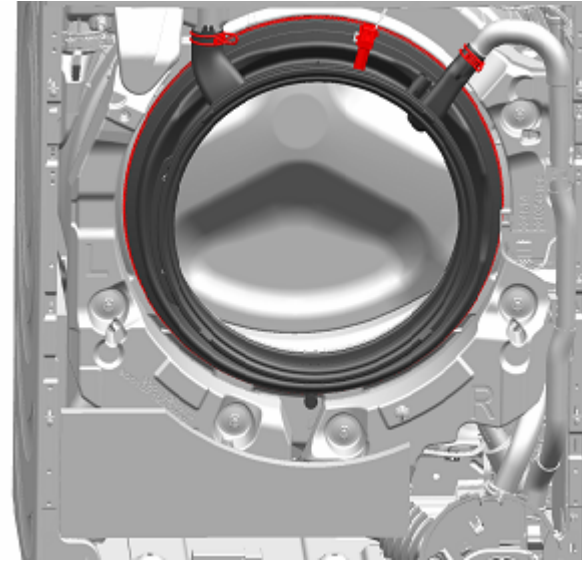





8. Fjern dørpakningen.

4.7.2 Montering af dørpakning

- ▶ Montér i omvendt rækkefølge.

4.8 Udskiftning af dørlås

Som producent er vi forpligtet til at sikre kunderne adgang til dørlåsen som reservedel, inklusive reparationsvejledningen, i overensstemmelse med forordning (EU) 2019/2023. Vi gør imidlertid opmærksom på, at det efter udskiftning af dørlåsen er nødvendigt med en elektroteknisk sikkerhedstest, der udføres af en kvalificeret elektriker, før apparatet tages i brug. Denne person skal være dokumenterbart kvalificeret i henhold til landespecifikke love, forskrifter og standarder.

| | |
|--|--|
|  | <p>⚠️ FARE</p> <p>Fare for elektrisk stød pga. spændingsførende dele! Livsfare pga. elektrisk stød i tilfælde af ukorrekt reparation</p> <ul style="list-style-type: none">▶ Elektriske dele skal repareres af kvalificerede elektrikere.▶ Få efter reparationen udført en sikkerhedstest i henhold til VDE 0701 eller landespecifikke forskrifter. |
|  | <p>⚠️ PAS PÅ!</p> <p>Skarpe huskanter! Snitlæsioner</p> <ul style="list-style-type: none">▶ Brug beskyttelseshandsker. |
|  | <p>⚠️ ADVARSEL</p> <p>Apparater på skrå kan glide! Knoglebrud/klemskader</p> <ul style="list-style-type: none">▶ Sørg for at sikre apparater mod at glide. |
|  | <p>⚠️ PAS PÅ!</p> <p>Fare for nedfaldende dele pga. løsnede skruer! Personskade pga. nedfaldende dele.</p> <ul style="list-style-type: none">▶ Sørg for at sikre komponenten mod at falde ned. |
|  | <p>BEMÆRK!</p> <p>Fare for nedfaldende dele pga. løsnede skruer! Beskadigelse af andre apparatdele eller kundens hjem, f.eks. gulvet.</p> <ul style="list-style-type: none">▶ Sørg for at sikre komponenten mod at falde ned. |

Preindstilling:

- ✔️ Apparatet er afbrudt fra strømforsyningen.
- ✔️ Apparatet er afbrudt fra vandforsyningen.

- ✔️ Der er fri adgang til apparaterne.
- ✔️ Møbelpanelet er fjernet.
- ✔️ Betjeningspanelet er fjernet.
- ✔️ [Døren er fjernet. → 74](#)
- ✔️ Spænderingen er fjernet.
- ✔️ Frontpanelet er fjernet.
- ✔️ Dørpakningen er fjernet.

4.8.1 Fjernelse af dørlås

1. Træk dørlåsstikket ud.
2. Frigør dørlåsen.



3. Fjern dørlåsen.

4.8.2 Montering af dørlås

Dørlåsen skal være i den korrekte position for at sikre apparatets nød-døråbningsfunktion.

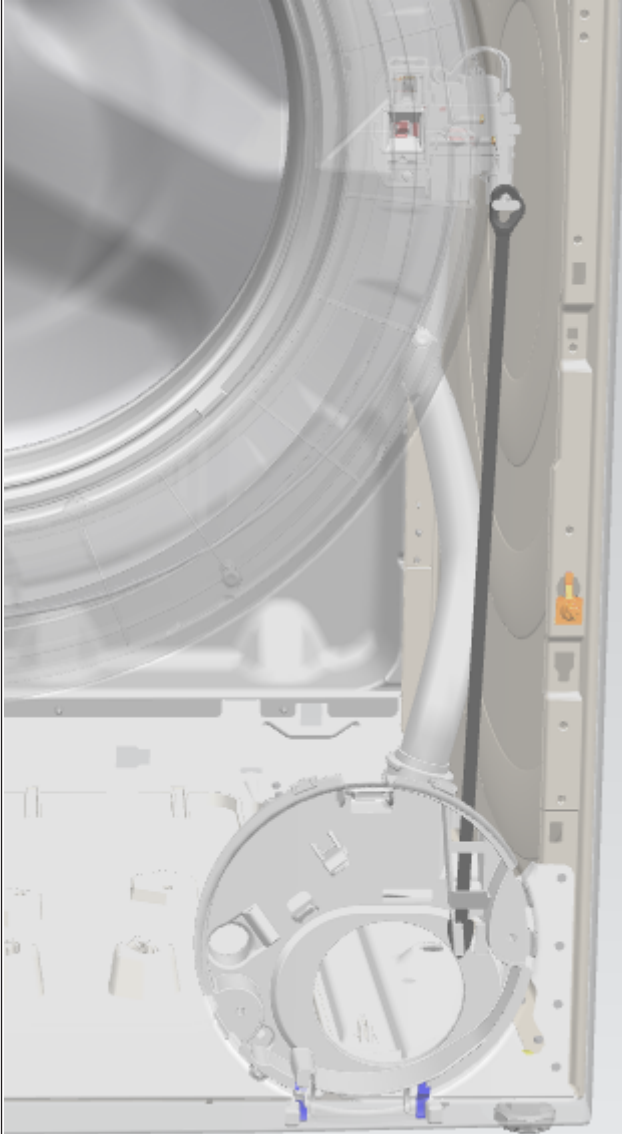

- ▶ Monter i omvendt rækkefølge.

4.9 Udskiftning af tromlelyys



⚠️ PAS PÅ!

Skarpe huskanter!
Snitlæsioner
▶ Brug beskyttelseshandsker.



⚠️ ADVARSEL

Apparater på skrå kan glide!
Knoglebrud/klemskader
▶ Sørg for at sikre apparater mod at glide.



⚠️ PAS PÅ!

Fare for nedfaldende dele pga. løsnede skruer!
Personskade pga. nedfaldende dele.
▶ Sørg for at sikre komponenten mod at falde ned.



BEMÆRK!

Fare for nedfaldende dele pga. løsnede skruer!
Beskadigelse af andre apparatdele eller kundens hjem, f.eks. gulvet.
▶ Sørg for at sikre komponenten mod at falde ned.

Preindstilling:

- ✔️ Apparatet er afbrudt fra strømforsyningen.
- ✔️ Apparatet er afbrudt fra vandforsyningen.
- ✔️ Der er fri adgang til apparaterne.
- ✔️ [Sæbeskuffen er fjernet.](#) →72
- ✔️ Betjeningspanelet er fjernet.

4.9.1 Fjernelse af tromlelyys

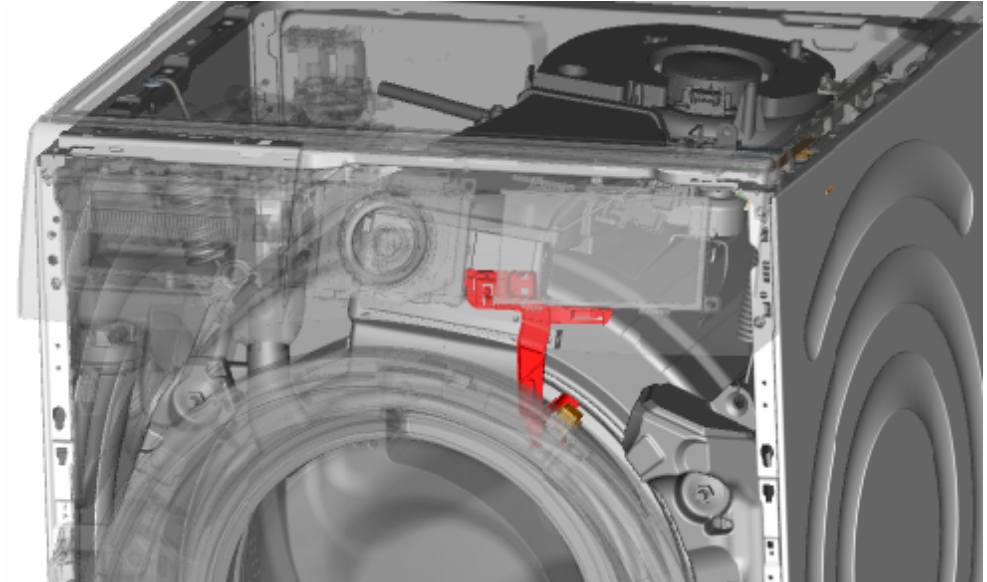

1. Træk tromlelysholderen ud af apparatet.
2. Afbryd de elektriske tilslutninger.
3. Fjern tromlelyset fra tromlelysholderen.

4.9.2 Montering af tromlelyse

- ▶ Montér i omvendt rækkefølge.

4.10 Udskiftning af afdækning fornedden



Fig. 1: Gruppeafdækning fornedden

Preindstilling:

- ✓ Apparatet er afbrudt fra strømforsyningen.
- ✓ Apparatet er afbrudt fra vandforsyningen.
- ✓ Møbelpanelet er fjernet.

4.10.1 Fjernelse af afdækning fornedden

Preindstilling:

- ✓ Apparatet er afbrudt fra strømforsyningen.
- ✓ Apparatet er afbrudt fra vandforsyningen.

1. Fjern afdækningen fornedden.

2. Afmonter slangen fra holderen.



Reparation

3. 1. Skru skruen ud (1).
2. Tryk på holdepunktet, og bevæg det nedad (2).

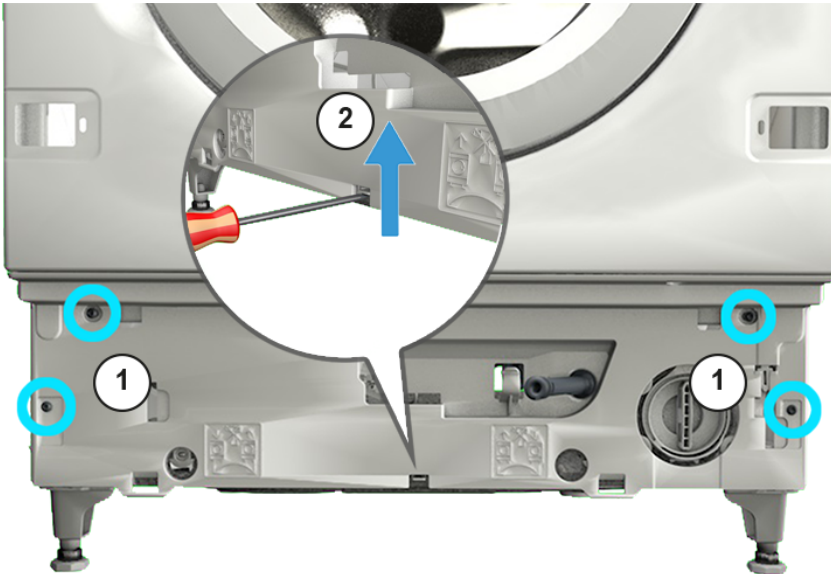

4. Træk i gruppeafdækningen forned, og bevæg den fremad.

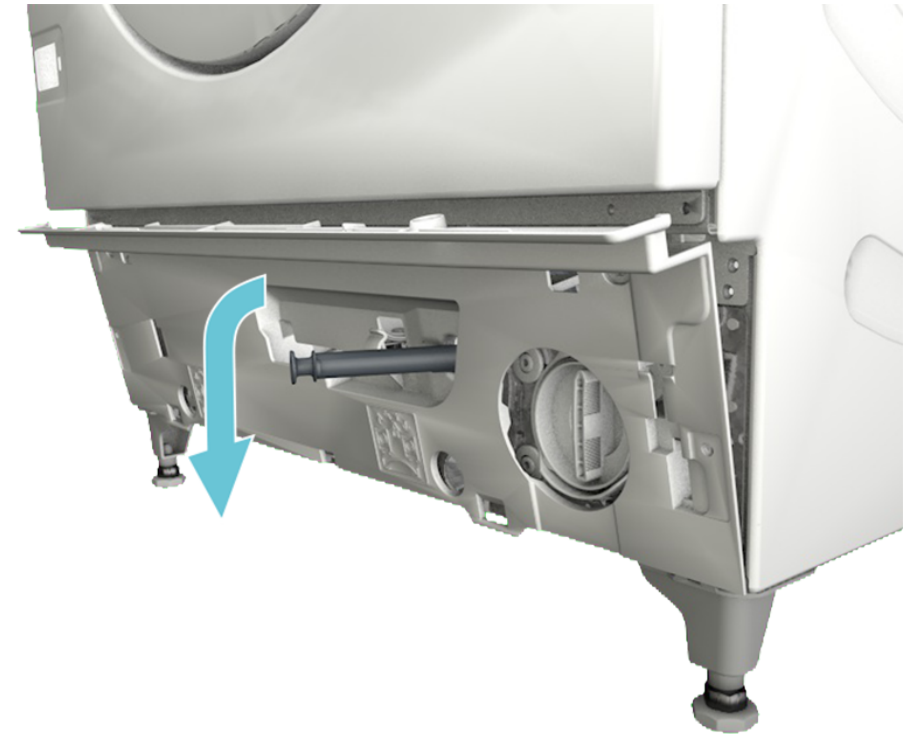

5. Træk slangen ud af afdækningen.

4.10.2 Montering af afdækningen

- Montér i omvendt rækkefølge.

4.11 Udskiftning af frontpanel



⚠ PAS PÅ!

Skarpe huskanter!

Snitlæsioner

- ▶ Brug beskyttelseshandsker.

Preindstilling:

- ✓ Apparatet er afbrudt fra strømforsyningen.
- ✓ Apparatet er afbrudt fra vandforsyningen.
- ✓ Der er fri adgang til apparaterne.
- ✓ [Sæbeskuffen er fjernet. →72](#)
- ✓ Møbelpanelet er fjernet.
- ✓ [Døren er fjernet. →74](#)
- ✓ Dørpakningen er fjernet.

4.11.1 Fjernelse af frontpanel

1. Løsn holderen på tromlelyset.

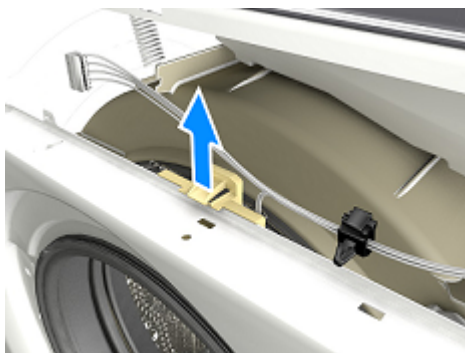

- 2.



⚠ PAS PÅ!

Fare for nedfaldende dele pga. løsnede skruer!

Personskade pga. nedfaldende dele.

- ▶ Sørg for at sikre komponenten mod at falde ned.



BEMÆRK!

Fare for nedfaldende dele pga. løsnede skruer!

Beskadigelse af andre apparatdele eller kundens hjem, f.eks. gulvet.

- ▶ Sørg for at sikre komponenten mod at falde ned.

Løsn skruberne i den viste rækkefølge.







3. Fjern frontpanelet.

4.11.2 Montering af frontpanel

- ▶ Montér i omvendt rækkefølge.

Reparatie informatie - Wasmachine

| | | | |
|--|-----------|--|-----|
|  Over dit document | 87 | 4.8 Deurslot vervangen | 100 |
| 1.1 Belangrijke informatie | 87 | 4.8.1 Deurslot verwijderen | 100 |
| 1.1.1 Doel | 87 | 4.8.2 Deurslot monteren | 101 |
| 1.2 Verklaring van symbolen | 87 | 4.9 Trommelverlichting vervangen | 102 |
| 1.2.1 Gevarenniveaus | 87 | 4.9.1 Trommelverlichting verwijderen | 102 |
| 1.2.2 Gevarensymbolen | 87 | 4.9.2 Trommelverlichting monteren | 102 |
| 1.2.3 Structuur van de waarschuwingen | 88 | 4.10 Onderklep vervangen | 103 |
| 1.2.4 Algemene symbolen | 88 | 4.10.1 Onderklep verwijderen | 103 |
|  Veiligheid | 89 | 4.10.2 De klep monteren | 104 |
| 2.1 Algemene veiligheidsinstructies | 89 | 4.11 Frontpaneel vervangen..... | 105 |
| 2.1.1 Alle huishoudelijke apparaten | 89 | 4.11.1 Frontpaneel verwijderen..... | 105 |
|  Gereedschappen en hulpmiddelen | 90 | 4.11.2 Frontpaneel monteren..... | 106 |
|  Reparatie | 91 | | |
| 4.1 Bedieningspaneel vervangen | 91 | | |
| 4.1.1 Bedieningspaneel verwijderen | 91 | | |
| 4.1.2 Bedieningspaneel monteren | 92 | | |
| 4.2 Wasmiddellade vervangen | 93 | | |
| 4.2.1 Wasmiddellade verwijderen | 93 | | |
| 4.2.2 Wasmiddellade monteren | 93 | | |
| 4.3 Handgreep wasmiddellade vervangen | 94 | | |
| 4.3.1 Handgreep wasmiddellade verwijderen | 94 | | |
| 4.3.2 Handgreep wasmiddellade monteren | 94 | | |
| 4.4 Deur vervangen..... | 95 | | |
| 4.4.1 Deur verwijderen..... | 95 | | |
| 4.4.2 Deur monteren..... | 95 | | |
| 4.5 Deurcomponenten vervangen | 96 | | |
| 4.5.1 Deurcomponenten verwijderen | 96 | | |
| 4.5.2 Deurcomponenten monteren | 96 | | |
| 4.6 Deurscharnier vervangen | 97 | | |
| 4.6.1 Deurscharnier verwijderen | 97 | | |
| 4.6.2 Deurscharnier monteren | 97 | | |
| 4.7 Deurafdichting vervangen | 98 | | |
| 4.7.1 Deurafdichting verwijderen | 98 | | |
| 4.7.2 Deurafdichting monteren | 99 | | |

i Over dit document

1.1 Belangrijke informatie

1.1.1 Doel

Met deze reparatieaanwijzingen wordt de klant geholpen zelf apparaten te repareren conform de toepasselijke verordening inzake ecologisch ontwerp (met ingang van 03/2021).





Ze bevatten informatie over hoe gedefinieerde reserveonderdelen kunnen worden vervangen met inbegrip van waarschuwingen en gevaren.

Neem bij vragen contact op met onze klantenservice. We stellen ons alleen aansprakelijk voor schade als de reparatieaanwijzingen correct zijn opgevolgd.

1.2 Verklaring van symbolen

1.2.1 Gevarenniveaus

De waarschuwningsniveaus worden aangegeven met een symbool en een signaalwoord. Het signaalwoord geeft de ernst van het gevaar aan.



| Waarschuwningsniveau | Betekenis |
|---|--|
|  | Als de waarschuwing niet in acht wordt genomen, leidt dat tot ernstig of dodelijk letsel. |
|  | Als de waarschuwing niet in acht wordt genomen, kan dat tot ernstig of dodelijk letsel leiden. |
|  | Als de waarschuwing niet in acht wordt genomen, kan dat tot licht letsel leiden. |
|  | Als de waarschuwing niet in acht wordt genomen, kan dat tot materiële schade leiden. |

Tabel 1: Gevarenniveaus

1.2.2 Gevarensymbolen

Gevarensymbolen zijn symbolische afbeeldingen die een indicatie geven van het soort gevaar.

De volgende gevarensymbolen worden in dit document gebruikt:

| Gevarensymbool | Betekenis |
|---|----------------------------------|
|  | Algemene waarschuwing |
|  | Gevaar voor elektrische spanning |
|  | Ontploffingsgevaar |
|  | Snijgevaar |

i Over dit document

| Gevarensymbool | Betekenis |
|--|---------------------------------------|
|  | Beknellingsgevaar |
|  | Gevaar voor hete oppervlakken |
|  | Gevaar voor sterke magnetische velden |
|  | Gevaar voor niet-ioniserende straling |

Tabel 2: Gevarensymbolen

1.2.3 Structuur van de waarschuwingen

Waarschuwingen in dit document hebben een gestandaardiseerd uiterlijk en een gestandaardiseerde structuur.







| | |
|--|---|
|  | <div style="background-color: red; color: white; padding: 2px; text-align: center;">⚠ GEVAAR</div> <p>Soort gevaar en bron van het gevaar! Mogelijke gevolgen van het negeren van het gevaar / de waarschuwing.</p> <ul style="list-style-type: none"> ▶ Maatregelen en verboden om het gevaar te voorkomen. |
|--|---|

In het volgende voorbeeld is een waarschuwing te zien waarmee voor een elektrische schok aan stroomvoerende onderdelen wordt gewaarschuwd. De maatregel om het gevaar te vermijden wordt vermeld.

| | |
|--|---|
|  | <div style="background-color: red; color: white; padding: 2px; text-align: center;">⚠ GEVAAR</div> <p>Gevaar voor een elektrische schok aan stroomvoerende onderdelen! Dood door elektrocutie</p> <ul style="list-style-type: none"> ▶ Haal apparaten minstens 60 seconden voor u met reparaties begint van de stroomvoorziening af. |
|--|---|

1.2.4 Algemene symbolen

De volgende algemene symbolen worden in dit document gebruikt:

| Alg. symbool | Betekenis |
|---|---|
|  | Identificatie van een speciale tip (tekst en/of afbeelding) |
|  | Identificatie van een eenvoudige tip (tekst) |
|  | Identificatie van een link naar een video-instructie |
|  | Identificatie van vereiste gereedschappen |
|  | Identificatie van vereiste voorwaarden |
|  | Identificatie van een voorwaarde (als ..., dan ...) |
|  | Identificatie van een resultaat |
| [Start] | Identificatie van een toets of knop |
| [00123456] | Identificatie van een materiaalnummer |
| Status | Identificatie van weergegeven tekst / venster (in het display van het apparaat) |

Tabel 3: Algemene symbolen

2.1 Algemene veiligheidsinstructies

2.1.1 Alle huishoudelijke apparaten

Gevaar voor een elektrische schok aan stroomvoerende onderdelen!

- Fouten bij reparaties aan elektrische componenten kunnen tot een elektrische schok leiden!
- Koppel het apparaat minstens 60 seconden los van het stroomnet voordat u met de werkzaamheden begint.
- Laat na de reparatie een veiligheidstest conform VDE 0701 of de landspecifieke regelgeving uitvoeren.

Gevaar voor letsel aan scherpe randen!

- Draag veiligheidshandschoenen.

Beknellingsgevaar tijdens reparatie, onderhoud, probleemoplossing en service vanwege zware en bewegende componenten

- Draag veiligheidsschoenen.
- Beveilig zware componenten tegen vallen.
- Steek geen lichaamsdelen in bewegende componenten.







Gevaar voor de veiligheid / werking van het apparaat!





- Gebruik uitsluitend originele reserveonderdelen.

Gevaar voor schade aan elektrostatisch gevoelige componenten (ESD's)!

- Raak de modules met inbegrip van de aansluitingen en geleiderbanen niet aan.

Gereedschappen en hulpmiddelen

| Benaming | Details | Afbeeldingen |
|--|--|--|
| Hulpgereedschap [15000155] | Gereedschap voor loshalen uit kunststof onderdelen |  |
| Torx T20 schroevendraaier met boorgat [00340764] | 100 mm, voor schroeven met borgpen |  |
| Momentsleutel [15000441] | Momentsleutel 20 - 100 Nm | |
| Sleufschroevendraaier [00340854] | Blad 3,5 mm x 0,6 mm x 100 mm, Beschermende isolatie 1000 V AC |  |
| Sleufschroevendraaier [00340855] | Blad 5,5 mm x 1,0 mm x 125 mm, Beschermende isolatie 1000 V AC |  |
| Naaldtang, gebogen [00341269] | Lengte 200 mm |  |
| Zijsnijtang [00342182] | Lengte: 200 mm |  |

| Benaming | Details | Afbeeldingen |
|-------------------------------|-----------------|---|
| Ring-steeksleutel [00340811] | Maat 10°mm, M6 |  |
| Combination wrench [00340814] | Maat 13°mm, M8 |  |
| Ring-steeksleutel [00340817] | Maat 17 mm, M10 |  |
| Ring-steeksleutel [15000459] | Maat 16°mm, M10 |  |

4.1 Bedieningspaneel vervangen



⚠️ VOORZICHTIG

Scherpe randen aan de behuizing!

Snijletsel

- ▶ Draag veiligheidshandschoenen.



⚠️ WAARSCHUWING

Weggliden van schuin staande apparaten!

Botbreuken / beknellingsletsel

- ▶ Beveilig apparaten tegen wegglijden.



⚠️ VOORZICHTIG

Gevaar voor vallende onderdelen als gevolg van losgeraakte schroeven!

Letsel als gevolg van vallende onderdelen.

- ▶ Beveilig component tegen vallen.



LET OP!

Gevaar voor vallende onderdelen als gevolg van losgeraakte schroeven!

Schade aan andere onderdelen van het apparaat of bij de klant thuis bijvoorbeeld aan de vloer.

- ▶ Beveilig component tegen vallen.

Voorwaarde:

- ✔ Apparaat wordt van de stroomvoorziening afgehaald.
- ✔ Apparaat wordt van de watervoorziening afgehaald.
- ✔ Het apparaat is vrij toegankelijk.
- ✔ [Wasmiddellade is verwijderd.](#) →93

4.1.1 Bedieningspaneel verwijderen

1. Maak vergrendelelement (1) los.
2. Verwijder de afdekking (2).

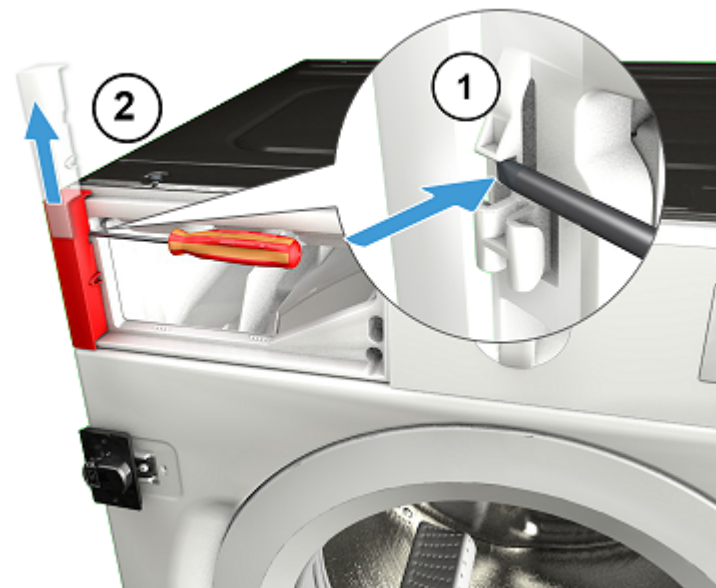

Reparatie

2. Verwijder schroeven.



3. 1. Maak vergrendelelementen (1, 2) los.
2. Trek het bedieningspaneel naar de voorkant (3).

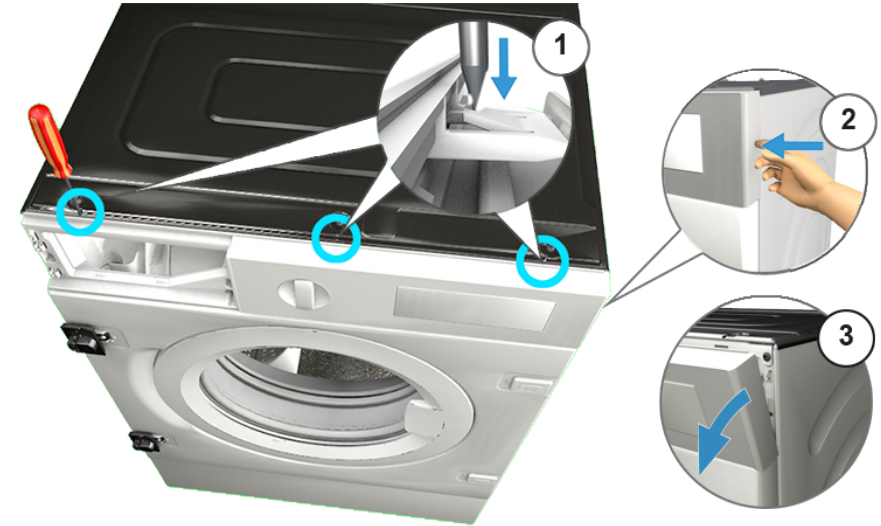

4. Verwijder het bedieningspaneel.

4.1.2 Bedieningspaneel monteren

- ▶ Monteer in omgekeerde volgorde.

4.2 Wasmiddellade vervangen

Voorwaarde:

- ✓ Apparaat wordt van de stroomvoorziening afgehaald.
- ✓ Apparaat wordt van de watervoorziening afgehaald.

4.2.1 Wasmiddellade verwijderen

1. Trek de wasmiddellade open.
2. 1. Druk het inzetstuk (1) omlaag.
2. Verwijder de wasmiddellade (2).

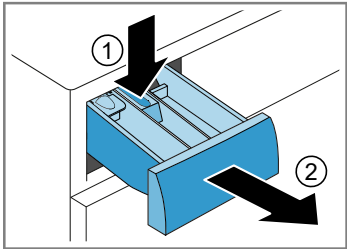

4.2.2 Wasmiddellade monteren

- ▶ Monteer in omgekeerde volgorde.

4.3 Handgreep wasmiddellade vervangen

Voorwaarde:

- ✓ Apparaat wordt van de stroomvoorziening afgehaald.
- ✓ Apparaat wordt van de watervoorziening afgehaald.
- ✓ [Wasmiddellade is verwijderd.→93](#)

4.3.1 Handgreep wasmiddellade verwijderen

1. Maak vergrendelelementen los.

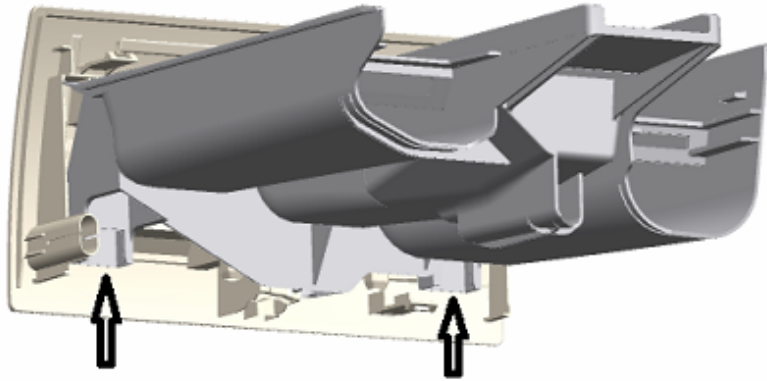

2. Verwijder de handgreep van de wasmiddellade.

4.3.2 Handgreep wasmiddellade monteren

- ▶ Monteer in omgekeerde volgorde.

4.4 Deur vervangen

| | |
|--|--|
|  | ⚠️ VOORZICHTIG Maak het scharniergedeelte open! Beknelling/afklemming van vingers <ul style="list-style-type: none">▶ Steek uw vingers niet in het scharniergedeelte.▶ Draag veiligheidshandschoenen. |
|--|--|

Voorwaarde:

- ✔ Apparaat wordt van de stroomvoorziening afgehaald.
- ✔ Apparaat wordt van de watervoorziening afgehaald.
- ✔ Deur wordt geopend.
- ✔ Behuizingsfront is verwijderd.

4.4.1 Deur verwijderen

1.

| | |
|---|---|
|  | LET OP! Gevaar voor vallende onderdelen als gevolg van losgeraakte schroeven! Schade aan andere onderdelen van het apparaat of bij de klant thuis bijvoorbeeld aan de vloer. <ul style="list-style-type: none">▶ Beveilig component tegen vallen. |
|---|---|

| | |
|--|--|
|  | ⚠️ VOORZICHTIG Gevaar voor vallende onderdelen als gevolg van losgeraakte schroeven! Letsel als gevolg van vallende onderdelen. <ul style="list-style-type: none">▶ Beveilig component tegen vallen. |
|--|--|

Verwijder schroeven (1).

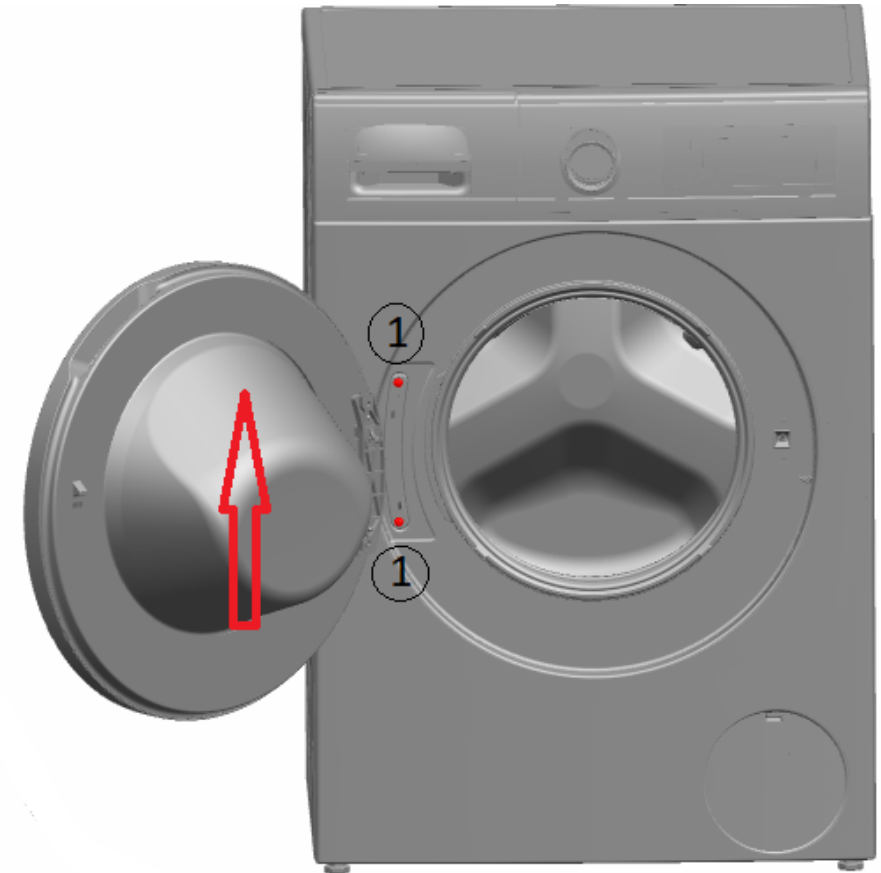

2. Verwijder deur naar boven toe.

4.4.2 Deur monteren

- ▶ Monteer in omgekeerde volgorde.

4.5 Deurcomponenten vervangen



VOORZICHTIG

Maak het scharniergedeelte open!

Beknelling/afklemming van vingers

- ▶ Steek uw vingers niet in het scharniergedeelte.
- ▶ Draag veiligheidshandschoenen.

Voorwaarde:

- ✔ Apparaat wordt van de stroomvoorziening afgehaald.
- ✔ Apparaat wordt van de watervoorziening afgehaald.
- ✔ Behuizingsfront is verwijderd.
- ✔ [Deur is verwijderd.→95](#)

4.5.1 Deurcomponenten verwijderen

- ▶ Demonteer de deur van buiten naar binnen.

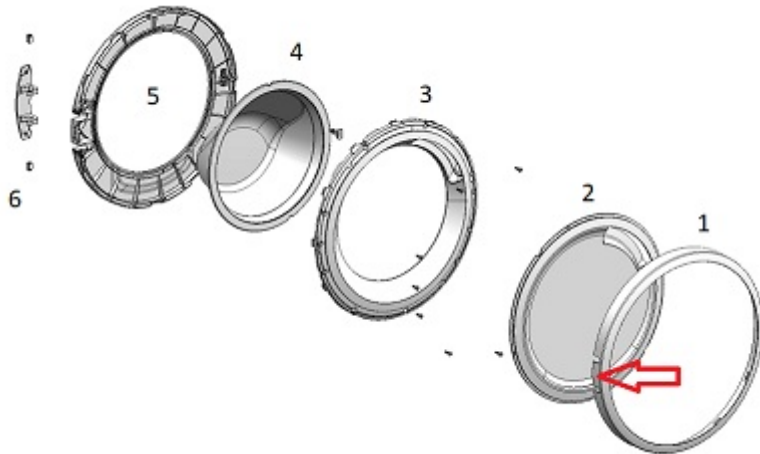

4.5.2 Deurcomponenten monteren

- ▶ Monteer in omgekeerde volgorde.

4.6 Deurscharnier vervangen



VOORZICHTIG

Maak het scharniergedeelte open!

Beknelling/afklemming van vingers

- ▶ Steek uw vingers niet in het scharniergedeelte.
- ▶ Draag veiligheidshandschoenen.

Voorwaarde:

- ✔ Apparaat wordt van de stroomvoorziening afgehaald.
- ✔ Apparaat wordt van de watervoorziening afgehaald.

4.6.1 Deurscharnier verwijderen

1. Draai de twee schroeven los.
2. Verwijder de deur.
3. Demonteer de deur van buiten naar binnen.

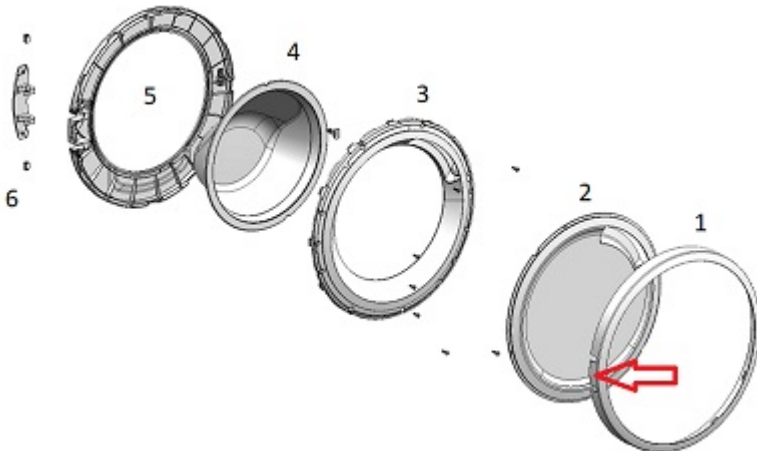

4. Verwijder het deurscharnier.

4.6.2 Deurscharnier monteren

- ▶ Monteer in omgekeerde volgorde.

4.7 Deurafdichting vervangen

| | |
|--|---|
|  | ⚠ VOORZICHTIG Scherpe randen aan de behuizing! Snijletsel ▶ Draag veiligheidshandschoenen. |
|--|---|

| | |
|--|--|
|  | ⚠ VOORZICHTIG Gevaar voor vallende onderdelen als gevolg van losgeraakte schroeven! Letsel als gevolg van vallende onderdelen. ▶ Beveilig component tegen vallen. |
|--|--|

| | |
|--|--|
|  | LET OP! Gevaar voor vallende onderdelen als gevolg van losgeraakte schroeven! Schade aan andere onderdelen van het apparaat of bij de klant thuis bijvoorbeeld aan de vloer. ▶ Beveilig component tegen vallen. |
|--|--|

Voorwaarde:

- ✔ Apparaat wordt van de stroomvoorziening afgehaald.
- ✔ Apparaat wordt van de watervoorziening afgehaald.
- ✔ Het apparaat is vrij toegankelijk.
- ✔ [Wasmiddellade is verwijderd.→93](#)
- ✔ Bedieningspaneel is verwijderd.
- ✔ [Deur is verwijderd.→95](#)
- ✔ [Onderklep is verwijderd.→103](#)

4.7.1 Deurafdichting verwijderen

1. Maak de houder van de trommelverlichting los.



2.

| | |
|---|--|
|  | LET OP! Gevaar voor beschadigd oppervlak! Het apparaatoppervlak kan krassen oplopen als verkeerde gereedschappen worden gebruikt. ▶ Gebruik uitsluitend kunststof gereedschappen om de spanring te vervangen. |
|---|--|

Haal de spanring met een kunststof gereedschap van de afdichting af.

3. Haal de deurafdichting los van het frontpaneel.
4. Haal de kabelstekker los van het deurslot.

Reparatie

5. Draai de schroeven in de aangegeven volgorde los.



6. Verwijder het frontpaneel.

7. Maak alle slangverbindingen los.

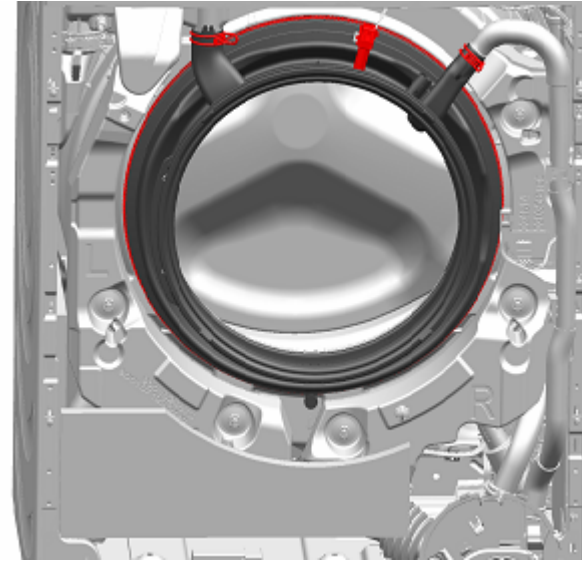

8. Verwijder de deurafdichting.

4.7.2 Deurafdichting monteren

► Monteer in omgekeerde volgorde.

4.8 Deurslot vervangen

Als fabrikant zijn wij conform Verordening (EU) 2019/2023 verplicht om consumenten een reservedeurbeveiliging inclusief reparatie-instructies te verstrekken. Wij willen u er echter op wijzen dat na vervanging van een deurbeveiliging een elektrotechnische veiligheidstest door een gekwalificeerde elektricien vereist is voordat het apparaat in gebruik mag worden genomen. Deze persoon moet aantoonbaar gekwalificeerd zijn op grond van de landspecifieke wetten, regelgeving en normen.

| | |
|--|---|
|  | ⚠ GEVAAR |
| | Gevaar voor een elektrische schok aan stroomvoerende onderdelen! Levensgevaar door elektrische schokken in geval van een ondeskundige reparatie <ul style="list-style-type: none">▶ Elektrische onderdelen moeten door gekwalificeerde elektriciens worden gerepareerd.▶ Laat na de reparatie een veiligheidstest conform VDE 0701 of de landspecifieke regelgeving uitvoeren. |

| | |
|--|--|
|  | ⚠ VOORZICHTIG |
| | Scherpe randen aan de behuizing! Snijletsel <ul style="list-style-type: none">▶ Draag veiligheidshandschoenen. |

| | |
|---|---|
|  | ⚠ WAARSCHUWING |
| | Weggliden van schuin staande apparaten! Botbreuken / beknellingsletsel <ul style="list-style-type: none">▶ Beveilig apparaten tegen wegglijden. |

| | |
|--|---|
|  | ⚠ VOORZICHTIG |
| | Gevaar voor vallende onderdelen als gevolg van losgeraakte schroeven! Letsel als gevolg van vallende onderdelen. <ul style="list-style-type: none">▶ Beveilig component tegen vallen. |

| | |
|---|---|
|  | LET OP! |
| | Gevaar voor vallende onderdelen als gevolg van losgeraakte schroeven! Schade aan andere onderdelen van het apparaat of bij de klant thuis bijvoorbeeld aan de vloer. <ul style="list-style-type: none">▶ Beveilig component tegen vallen. |

Voorwaarde:

- ✔ Apparaat wordt van de stroomvoorziening afgehaald.
- ✔ Apparaat wordt van de watervoorziening afgehaald.
- ✔ Het apparaat is vrij toegankelijk.
- ✔ Behuizingsfront is verwijderd.
- ✔ Bedieningspaneel is verwijderd.
- ✔ [Deur is verwijderd. → 95](#)
- ✔ Spanring is verwijderd.
- ✔ Frontpaneel is verwijderd.
- ✔ Deurafdichting is verwijderd.

4.8.1 Deurslot verwijderen

1. Haal de stekker van het deurslot los.
2. Maak het deurslot los.



3. Verwijder het deurslot.

4.8.2 Deurslot monteren

Het deurslot moet in de juiste positie worden bevestigd om te waarborgen dat de deuropeningsfunctie in geval van nood werkt.



- ▶ Monteer in omgekeerde volgorde.

4.9 Trommelverlichting vervangen



⚠ VOORZICHTIG

Scherpe randen aan de behuizing!
Snijletsel
▶ Draag veiligheidshandschoenen.



⚠ WAARSCHUWING

Weggliden van schuin staande apparaten!
Botbreuken / beknellingsletsel
▶ Beveilig apparaten tegen wegglijden.



⚠ VOORZICHTIG

Gevaar voor vallende onderdelen als gevolg van losgeraakte schroeven!
Letsel als gevolg van vallende onderdelen.
▶ Beveilig component tegen vallen.



LET OP!

Gevaar voor vallende onderdelen als gevolg van losgeraakte schroeven!
Schade aan andere onderdelen van het apparaat of bij de klant thuis bijvoorbeeld aan de vloer.
▶ Beveilig component tegen vallen.

Voorwaarde:

- ✔ Apparaat wordt van de stroomvoorziening afgehaald.
- ✔ Apparaat wordt van de watervoorziening afgehaald.
- ✔ Het apparaat is vrij toegankelijk.
- ✔ [Wasmiddellade is verwijderd.](#) →93
- ✔ Bedieningspaneel is verwijderd.

4.9.1 Trommelverlichting verwijderen

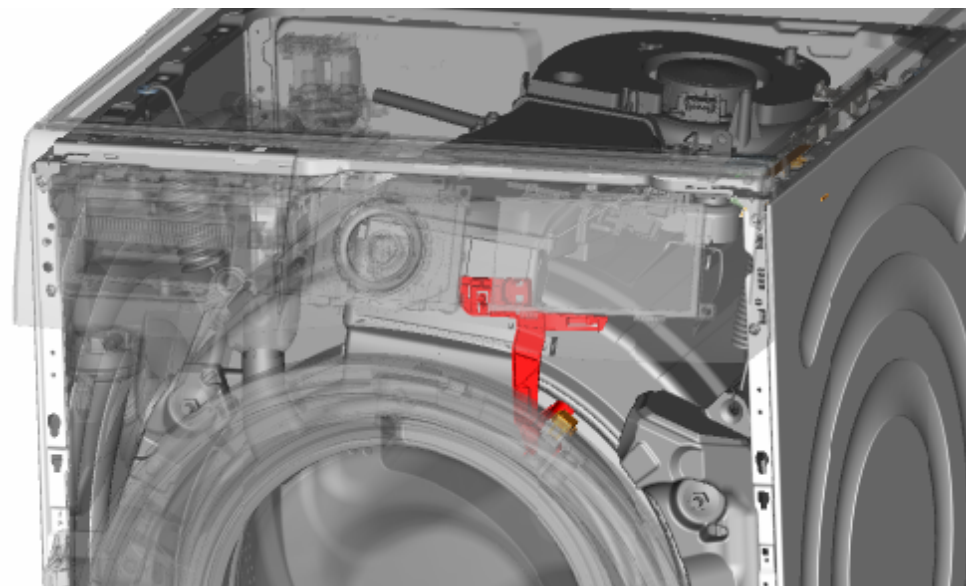

1. Trek de houder van de trommelverlichting uit het apparaat.
2. Haal de elektrische verbindingen los.
3. Haal de trommelverlichting uit de houder.

4.9.2 Trommelverlichting monteren

- ▶ Monteer in omgekeerde volgorde.

4.10 Onderklep vervangen



Afb. 1: Klep bodemgroep

Voorwaarde:

- ✔ Apparaat wordt van de stroomvoorziening afgehaald.
- ✔ Apparaat wordt van de watervoorziening afgehaald.
- ✔ Behuizingsfront is verwijderd.

4.10.1 Onderklep verwijderen

Voorwaarde:

- ✔ Apparaat wordt van de stroomvoorziening afgehaald.
- ✔ Apparaat wordt van de watervoorziening afgehaald.

1. Verwijder de onderklep.

2. Haal de slang los van de houder.

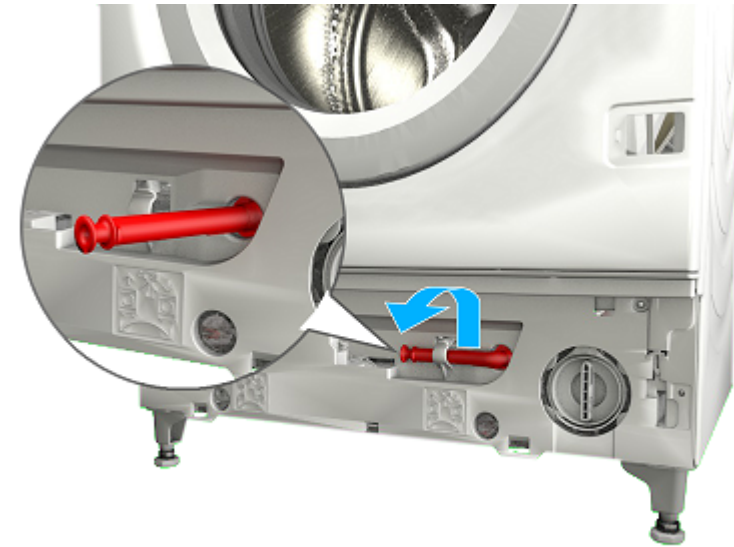

Reparatie

3. 1. Draai de schroef (1) los.
2. Druk op het bevestigingspunt en verwijder naar beneden toe (2).

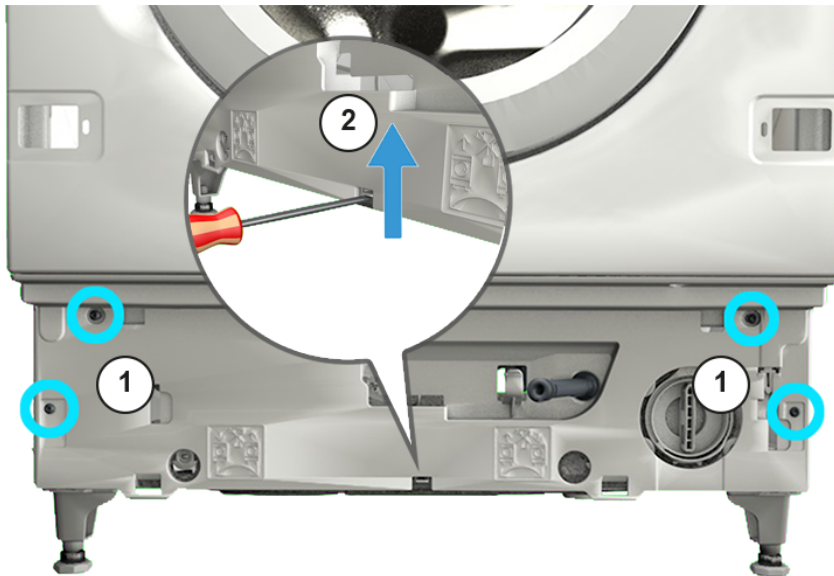

4. Trek aan de klep van de bodemgroep en verwijder hem naar voren toe.

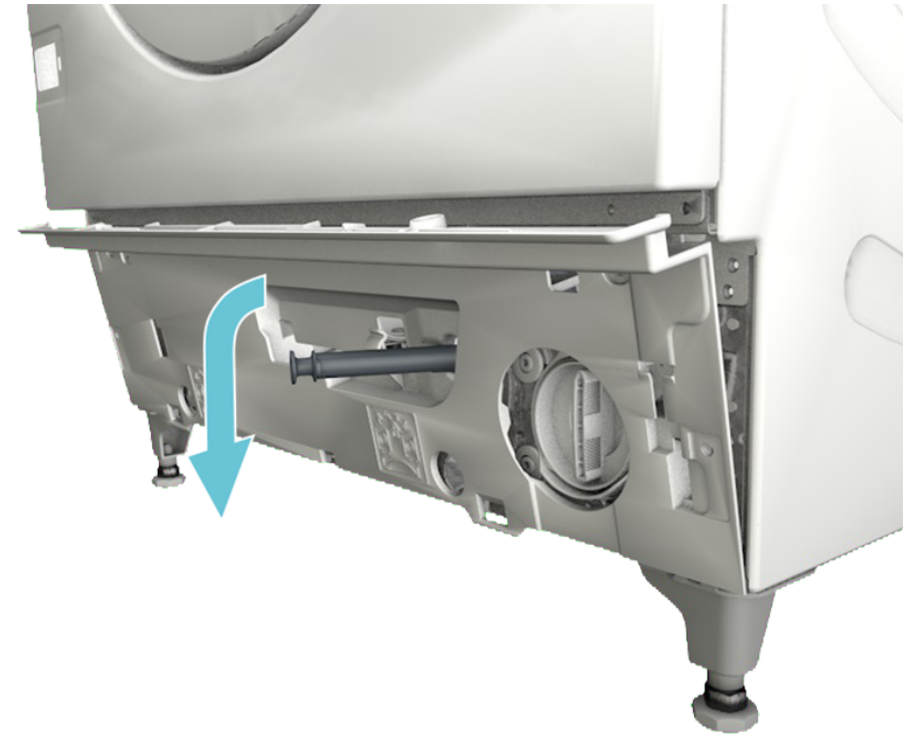

5. Trek de slang uit de klep.

4.10.2 De klep monteren

- Monteer in omgekeerde volgorde.

4.11 Frontpaneel vervangen

| | |
|--|--|
|  | <p>⚠ VOORZICHTIG</p> <p>Scherpe randen aan de behuizing! Snijletsel</p> <ul style="list-style-type: none">▶ Draag veiligheidshandschoenen. |
|--|--|

Voorwaarde:

- ✓ Apparaat wordt van de stroomvoorziening afgehaald.
- ✓ Apparaat wordt van de watervoorziening afgehaald.
- ✓ Het apparaat is vrij toegankelijk.
- ✓ [Wasmiddellade is verwijderd.→93](#)
- ✓ Behuizingsfront is verwijderd.
- ✓ [Deur is verwijderd.→95](#)
- ✓ Deurafdichting is verwijderd.

4.11.1 Frontpaneel verwijderen

1. Maak de houder van de trommelverlichting los.

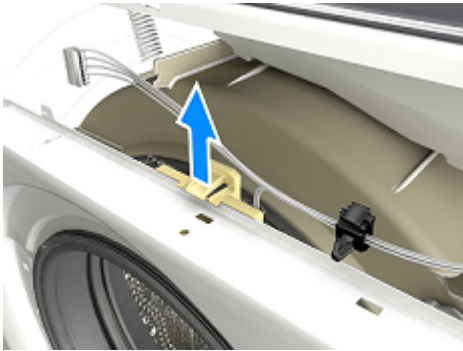

2.

| | |
|---|---|
|  | <p>⚠ VOORZICHTIG</p> <p>Gevaar voor vallende onderdelen als gevolg van losgeraakte schroeven! Letsel als gevolg van vallende onderdelen.</p> <ul style="list-style-type: none">▶ Beveilig component tegen vallen. |
|---|---|

| | |
|---|---|
|  | <p>LET OP!</p> <p>Gevaar voor vallende onderdelen als gevolg van losgeraakte schroeven! Schade aan andere onderdelen van het apparaat of bij de klant thuis bijvoorbeeld aan de vloer.</p> <ul style="list-style-type: none">▶ Beveilig component tegen vallen. |
|---|---|

Reparatie

Draai de schroeven in de aangegeven volgorde los.







3. Verwijder het frontpaneel.

4.11.2 Frontpaneel monteren

► Monteer in omgekeerde volgorde.

Self-repair hints - Washing machine

| | |
|--|------------|
|  Concerning this document | 108 |
| 1.1 Important information | 108 |
| 1.1.1 Purpose..... | 108 |
| 1.2 Explanation of symbols | 108 |
| 1.2.1 Danger levels..... | 108 |
| 1.2.2 Hazard symbols | 108 |
| 1.2.3 Structure of the warnings..... | 109 |
| 1.2.4 General symbols..... | 109 |
|  Safety | 110 |
| 2.1 General Safety instructions | 110 |
| 2.1.1 All domestic appliances | 110 |
|  Tools and aids | 111 |
|  Repair | 112 |
| 4.1 Replacing fascia panel..... | 112 |
| 4.1.1 Removing fascia panel | 112 |
| 4.1.2 Installing fascia panel | 113 |
| 4.2 Replacing detergent drawer | 114 |
| 4.2.1 Removing detergent drawer..... | 114 |
| 4.2.2 Installing detergent drawer..... | 114 |
| 4.3 Replacing detergent drawer handle | 115 |
| 4.3.1 Removing detergent drawer handle..... | 115 |
| 4.3.2 Installing detergent drawer handle..... | 115 |
| 4.4 Replacing door | 116 |
| 4.4.1 Removing door | 116 |
| 4.4.2 Installing door | 116 |
| 4.5 Replacing door components..... | 117 |
| 4.5.1 Removing door components | 117 |
| 4.5.2 Installing door components | 117 |
| 4.6 Replacing door hinge..... | 118 |
| 4.6.1 Removing door hinge | 118 |
| 4.6.2 Installing door hinge | 118 |
| 4.7 Replacing door seal..... | 119 |
| 4.7.1 Removing door seal | 119 |
| 4.7.2 Installing door seal | 120 |

| | |
|------------------------------------|-----|
| 4.8 Replacing door lock..... | 121 |
| 4.8.1 Removing door lock..... | 121 |
| 4.8.2 Installing door lock..... | 122 |
| 4.9 Replacing drum light | 123 |
| 4.9.1 Removing drum light..... | 123 |
| 4.9.2 Installing drum light..... | 123 |
| 4.10 Replacing bottom cover..... | 124 |
| 4.10.1 Removing bottom cover | 124 |
| 4.10.2 Installing the cover..... | 125 |
| 4.11 Replacing front panel | 126 |
| 4.11.1 Removing front panel..... | 126 |
| 4.11.2 Installing front panel..... | 127 |

i Concerning this document

1.1 Important information

1.1.1 Purpose

These repair hints support consumer to repair appliances by himself according to the applicable eco-design regulation (as of 03/2021).

They contain information how to exchange defined spare parts including warnings and risks.

In case of questions, please contact our customer service. We will only be liable for damages if the repair hints have been followed properly.

1.2 Explanation of symbols

1.2.1 Danger levels

The warning levels consist of a symbol and a signal word. The signal word indicates the severity of the danger.









| Warning level | Meaning |
|---|--|
|  | Non-observance of the warning message will result in death or serious injuries. |
|  | Non-observance of the warning message could result in death or serious injuries. |
|  | Non-observance of the warning message could result in minor injuries. |
|  | Non-observance of the warning message could result in damage to property. |

Table 1: Danger levels

1.2.2 Hazard symbols

Hazard symbols are symbolic representations which give an indication of the kind of danger.

The following hazard symbols are used in this document:

| Hazard symbol | Meaning |
|---|--------------------------------|
|  | General warning message |
|  | Danger from electrical voltage |
|  | Risk of explosion |
|  | Danger of cuts |
|  | Danger of crushing |

Concerning this document



| Hazard symbol | Meaning |
|--|------------------------------------|
|  | Danger from hot surfaces |
|  | Danger from strong magnetic field |
|  | Danger from non-ionizing radiation |

Table 2: Hazard symbols

1.2.3 Structure of the warnings

Warnings in this document have a standardised appearance and a standardised structure.



| | |
|--|---|
|  | <div style="background-color: red; color: white; padding: 2px; text-align: center;"> Danger</div> <p>Type and source of danger! Possible consequences of ignoring the danger / warning.</p> <ul style="list-style-type: none"> ▶ Measures and prohibitions for preventing the danger. |
|--|---|

The following example shows a warning that warns against electric shock due to live parts. The measure for avoiding the danger is mentioned.

| | |
|---|---|
|  | <div style="background-color: red; color: white; padding: 2px; text-align: center;"> Danger</div> <p>Risk of electric shock due to live parts! Death by electrocution</p> <ul style="list-style-type: none"> ▶ Disconnect appliances from electrical supply at least 60 seconds before starting repairs. |
|---|---|

1.2.4 General symbols

The following general symbols are used in this document:

| Gen. symbol | Meaning |
|--|---|
|  | Identification of a special tip (text and/or graphic) |
|  | Identification of a simple tip (only text) |
|  | Identification of a link to a video tutorial |





| Gen. symbol | Meaning |
|---|--|
|  | Identification of required tools |
|  | Identification of required preconditions |
|  | Identification of a condition (if ..., then ...) |
|  | Identification of a result |
| [Start] | Identification of a key or button |
| [00123456] | Identification of a material number |
| Status | Identification of displayed text / window (in the appliance's display) |

Table 3: General symbols

2.1 General Safety instructions

2.1.1 All domestic appliances

Risk of electric shock due to live parts!

- Errors by repairs involving electrical components can lead to electrical shock!
- Disconnect the appliance from the mains for at least 60 seconds before starting work.
- After the repair have a safety test according VDE 0701 or country-specific regulations performed.

Risk of injury from sharp edges!

- Wear protective gloves.

Risk of crushing during repair, maintenance, troubleshooting and service due to heavy and moving components

- Wear protective shoes.
- Secure heavy components from falling down.
- Do not stick body parts into moving components.







Risk to the appliance's safety / function!





- Only use original spare parts.

Risk of damage to electrostatically sensitive components (ESDs)!





- Do not touch the modules, including connections and conductor paths.

Tools and aids

| Designation | Details | Images |
|---|---|--|
| Auxiliary tool [15000155] | Tool for loosening out of plastic parts |  |
| Screwdriver Torx T20 with bore hole [00340764] | 100 mm, for screws with safety pin |  |
| Torque spanner [15000441] | Torque spanner 20 - 100 Nm | |
| Slot screwdriver [00340854] | Blade 3.5 mm x 0.6 mm x 100 mm, Protective Insulation 1000 V AC |  |
| Slot screwdriver [00340855] | Blade 5.5 mm x 1.0 mm x 125 mm, Protective Insulation 1000 V AC |  |
| Needle-nose pliers, angled pattern [00341269] | Length 200 mm |  |
| Side-cutting pliers [00342182] | Length: 200 mm |  |

| Designation | Details | Images |
|----------------------------------|------------------------|---|
| Combination wrench [00340811] | Wrench size 10°mm, M6 |  |
| Combination wrench [00340814] | Wrench size 13°mm, M8 |  |
| Combination wrench [00340817] | Wrench size 17 mm, M10 |  |
| Combination wrench [15000459] | Wrench size 16°mm, M10 |  |

4.1 Replacing fascia panel

| | |
|--|---|
|  | <p>Caution</p> <p>Sharp housing edges! Cut injuries</p> <ul style="list-style-type: none">▶ Wear protective gloves. |
|  | <p>Warning</p> <p>Slipping of tilted appliances! Bone fractures / crush injuries</p> <ul style="list-style-type: none">▶ Secure appliances against slipping. |
|  | <p>Caution</p> <p>Risk of falling parts due to released screws! Injury because of falling parts.</p> <ul style="list-style-type: none">▶ Secure component from falling down. |
|  | <p>Notice</p> <p>Risk of falling parts due to released screws! Damage to other parts of the appliance or at customers home e.g. bottom.</p> <ul style="list-style-type: none">▶ Secure component from falling down. |

Prerequisite:

- ✓ Appliance is disconnected from power supply.
- ✓ Appliance is disconnected from water supply.
- ✓ Appliances is freely accessible.
- ✓ [Detergent drawer has been removed. → Page 114](#)

4.1.1 Removing fascia panel

1. Release catch element (1).
2. Remove cover (2).

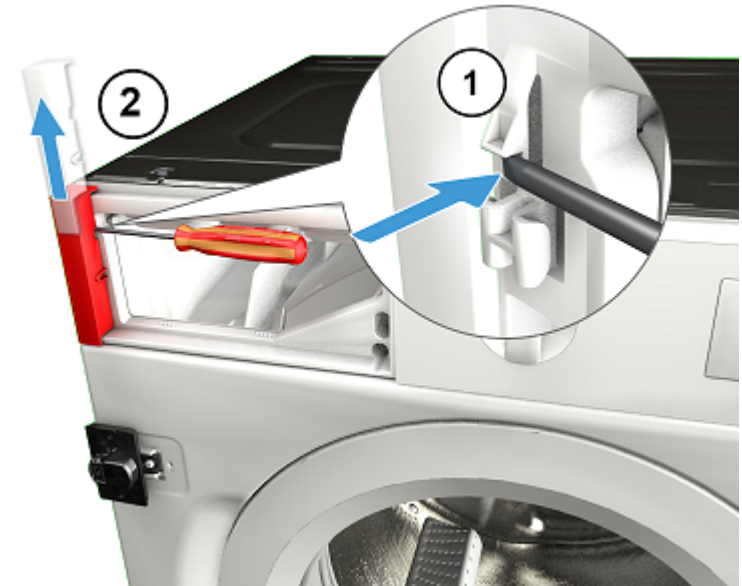

2. Remove screws.



3. 1. Release catch elements (1, 2).
2. Pull fascia panel to the front (3).

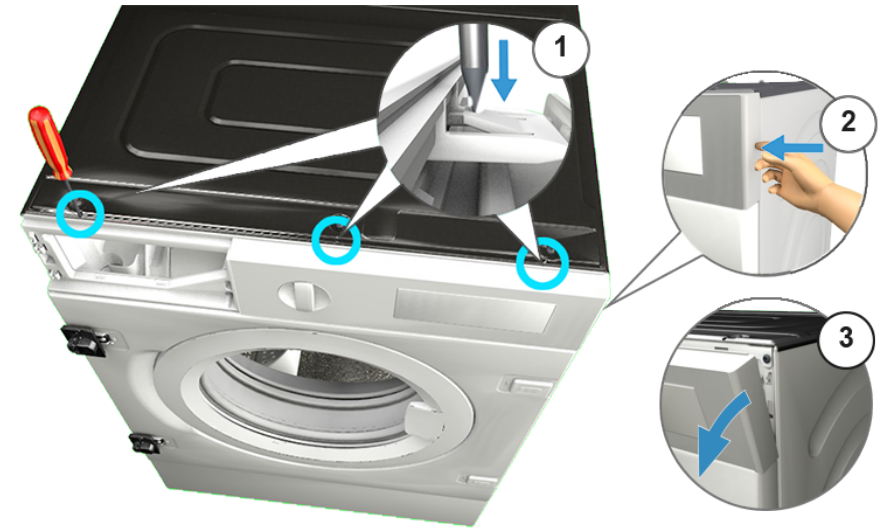

4. Remove fascia panel.

4.1.2 Installing fascia panel

► Install in reverse order.

4.2 Replacing detergent drawer

Prerequisite:

- ✔ Appliance is disconnected from power supply.
- ✔ Appliance is disconnected from water supply.

4.2.1 Removing detergent drawer

1. Pull out detergent drawer.
2.
 1. Press down on insert (1).
 2. Remove detergent drawer (2).

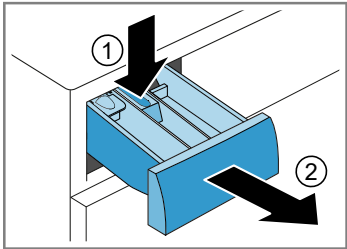

4.2.2 Installing detergent drawer

- ▶ Install in reverse order.

4.3 Replacing detergent drawer handle

Prerequisite:

- ✓ Appliance is disconnected from power supply.
- ✓ Appliance is disconnected from water supply.
- ✓ [Detergent drawer has been removed.](#) → [Page 114](#)

4.3.1 Removing detergent drawer handle

1. Release catch elements.

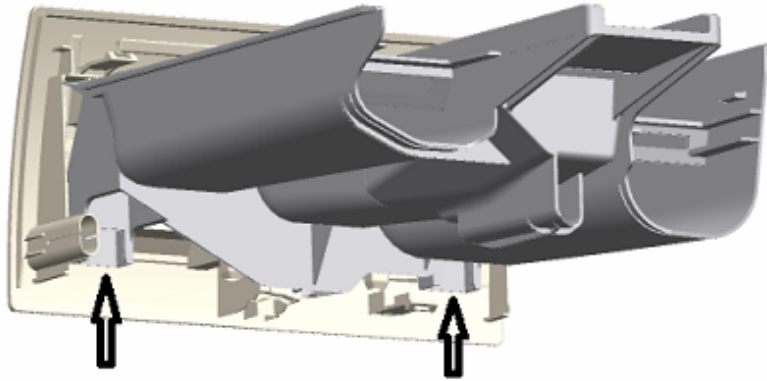

2. Remove detergent drawer handle.

4.3.2 Installing detergent drawer handle

- ▶ Install in reverse order.

4.4 Replacing door

| | |
|--|---|
|  | ⚠ Caution Open hinge area! Finger crushing / entrapment <ul style="list-style-type: none">▶ Do not reach into the hinge area.▶ Wear protective gloves. |
|--|---|

Prerequisite:

- ✔ Appliance is disconnected from power supply.
- ✔ Appliance is disconnected from water supply.
- ✔ Door is opened.
- ✔ Furniture panel has been removed.

4.4.1 Removing door

1.

| | |
|---|---|
|  | Notice Risk of falling parts due to released screws! Damage to other parts of the appliance or at customers home e.g. bottom. <ul style="list-style-type: none">▶ Secure component from falling down. |
|---|---|

| | |
|--|--|
|  | ⚠ Caution Risk of falling parts due to released screws! Injury because of falling parts. <ul style="list-style-type: none">▶ Secure component from falling down. |
|--|--|

Remove screws (1).

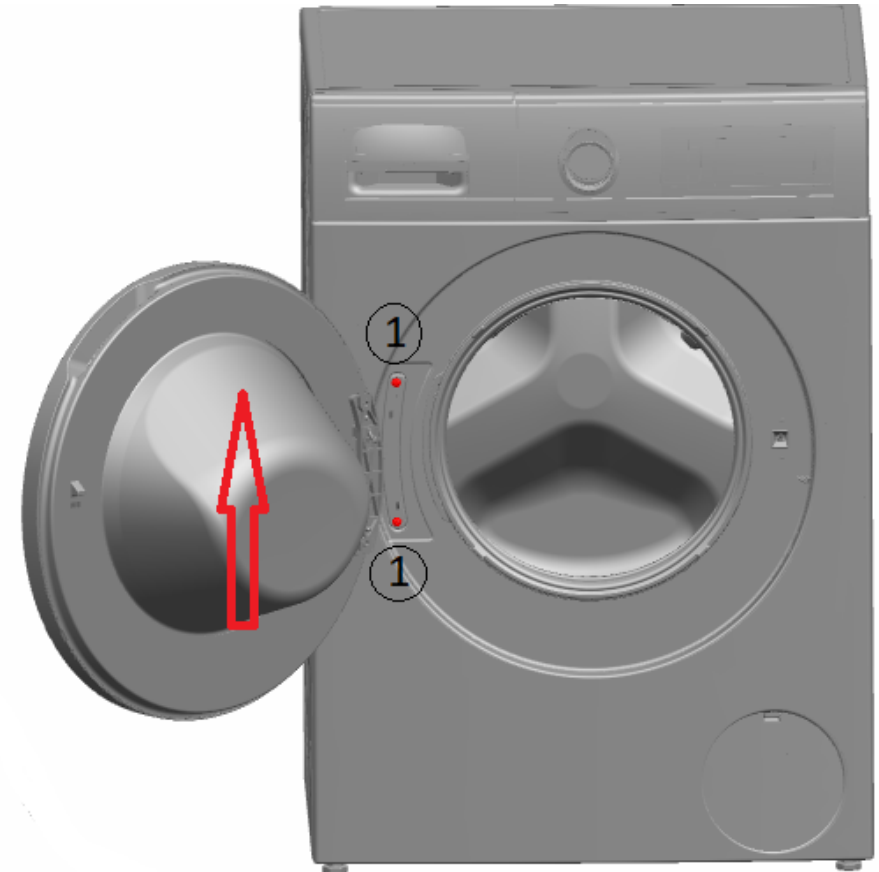

2. Remove door upwards.

4.4.2 Installing door

- ▶ Install in reverse order.

4.5 Replacing door components



Caution

Open hinge area!

Finger crushing / entrapment

- ▶ Do not reach into the hinge area.
- ▶ Wear protective gloves.

Prerequisite:

- ✔ Appliance is disconnected from power supply.
- ✔ Appliance is disconnected from water supply.
- ✔ Furniture panel has been removed.
- ✔ [Door has been removed.](#) → [Page 116](#)

4.5.1 Removing door components

- ▶ Disassemble door from outside to inside.

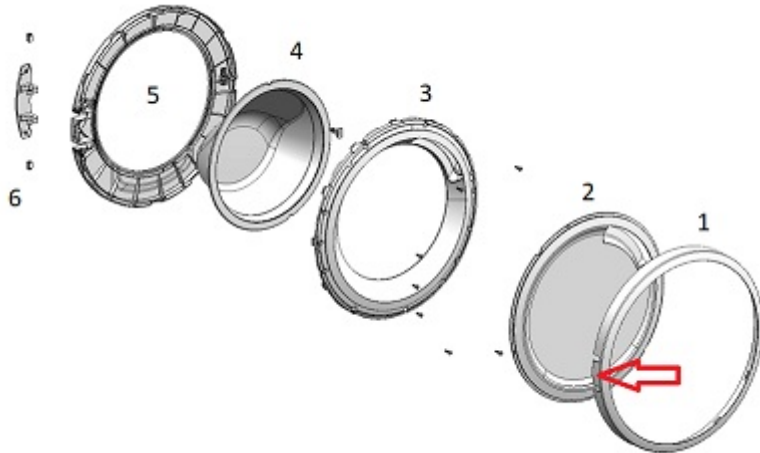

4.5.2 Installing door components

- ▶ Install in reverse order.

4.6 Replacing door hinge



Caution

Open hinge area!

Finger crushing / entrapment

- ▶ Do not reach into the hinge area.
- ▶ Wear protective gloves.

Prerequisite:

- ✔ Appliance is disconnected from power supply.
- ✔ Appliance is disconnected from water supply.

4.6.1 Removing door hinge

1. Release two screws.
2. Remove door.
3. Disassemble door from outside to inside.

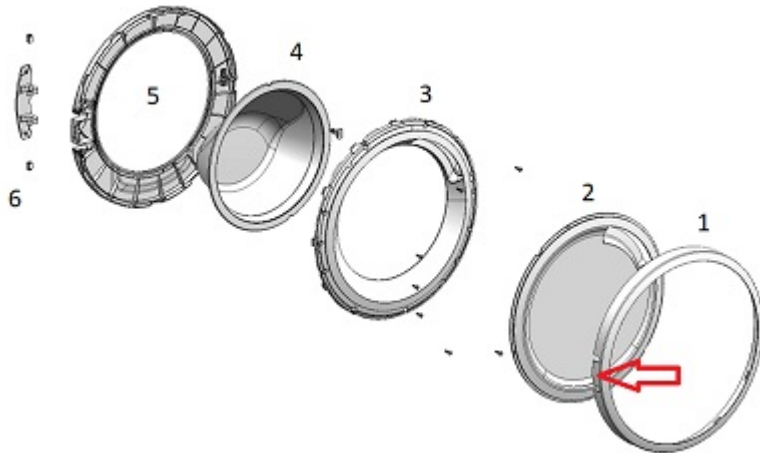



4. Remove door hinge.

4.6.2 Installing door hinge

- ▶ Install in reverse order.

4.7 Replacing door seal

| | |
|--|--|
|  | Caution Sharp housing edges! Cut injuries ▶ Wear protective gloves. |
|--|--|

| | |
|--|---|
|  | Caution Risk of falling parts due to released screws! Injury because of falling parts. ▶ Secure component from falling down. |
|--|---|

| | |
|--|--|
|  | Notice Risk of falling parts due to released screws! Damage to other parts of the appliance or at customers home e.g. bottom. ▶ Secure component from falling down. |
|--|--|

Prerequisite:

- ✓ Appliance is disconnected from power supply.
- ✓ Appliance is disconnected from water supply.
- ✓ Appliances is freely accessible.
- ✓ [Detergent drawer has been removed.→ Page 114](#)
- ✓ Fascia panel has been removed.
- ✓ [Door has been removed.→ Page 116](#)
- ✓ [Bottom cover has been removed.→ Page 124](#)

4.7.1 Removing door seal

1. Loosen the retainer on the drum light.

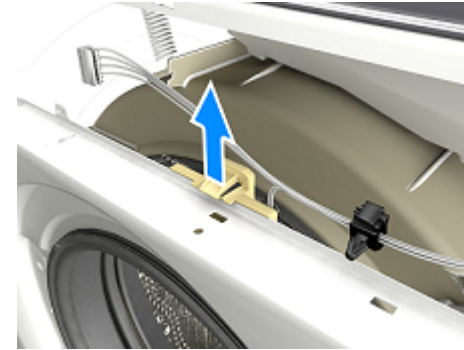

2.

| | |
|---|--|
|  | Notice Risk of damaged surface! Surface of appliance can be scratched by using wrong tools. ▶ Only use plastic tools to replace the tension ring. |
|---|--|

Remove tension ring from gasket with a plastic tool.

3. Release door seal from front panel.
4. Release cable connector from door lock.

5. Loosen the screws in the indicated order.



6. Remove front panel.

7. Disconnect all hose connections.

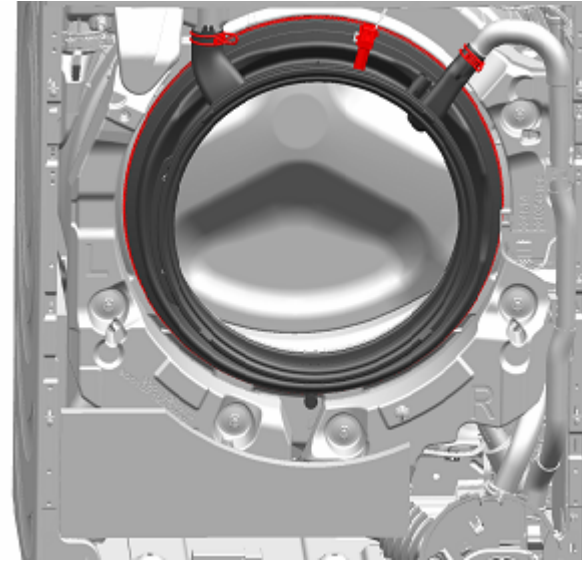





8. Remove door seal.

4.7.2 Installing door seal

- ▶ Install in reverse order.

4.8 Replacing door lock

As a manufacturer, we are obliged to provide consumers with the spare part door lock including repair instructions in accordance with Regulation (EU) 2019/2023. However, we would like to point out that after replacing a door lock, an electrotechnical safety test by a qualified electrician is required before the device is put into operation. This person must be verifiably qualified according to the country-specific laws, regulations and standards.

| | |
|--|--|
|  | <p style="text-align: center;">Danger</p> <p>Risk of electric shock due to live parts! Danger to life through electric shock in case of improper repair</p> <ul style="list-style-type: none"> ▶ Electric parts should be repaired by a qualified electricians. ▶ After the repair have a safety test according VDE 0701 or country-specific regulations performed. |
|  | <p style="text-align: center;">Caution</p> <p>Sharp housing edges! Cut injuries</p> <ul style="list-style-type: none"> ▶ Wear protective gloves. |
|  | <p style="text-align: center;">Warning</p> <p>Slipping of tilted appliances! Bone fractures / crush injuries</p> <ul style="list-style-type: none"> ▶ Secure appliances against slipping. |
|  | <p style="text-align: center;">Caution</p> <p>Risk of falling parts due to released screws! Injury because of falling parts.</p> <ul style="list-style-type: none"> ▶ Secure component from falling down. |
|  | <p style="text-align: center;">Notice</p> <p>Risk of falling parts due to released screws! Damage to other parts of the appliance or at customers home e.g. bottom.</p> <ul style="list-style-type: none"> ▶ Secure component from falling down. |

Prerequisite:

- ✓ Appliance is disconnected from power supply.
- ✓ Appliance is disconnected from water supply.

- ✓ Appliances is freely accessible.
- ✓ Furniture panel has been removed.
- ✓ Fascia panel has been removed.
- ✓ [Door has been removed.](#) → [Page 116](#)
- ✓ Tension ring has been removed.
- ✓ Front panel has been removed.
- ✓ Door seal has been removed.

4.8.1 Removing door lock

1. Disconnect door lock plug.
2. Release door lock.



3. Remove door lock.

4.8.2 Installing door lock

Door lock must be in the right position to ensure the emergency door opening function of the appliance.

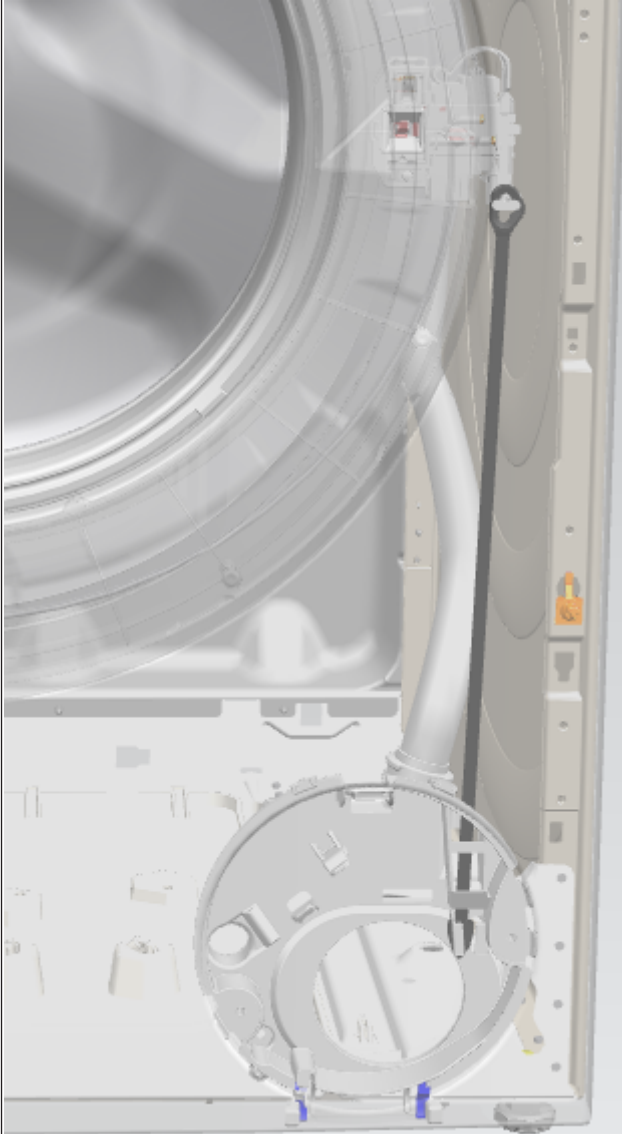

- ▶ Install in reverse order.

4.9 Replacing drum light



Caution

Sharp housing edges!
Cut injuries
▶ Wear protective gloves.



Warning

Slipping of tilted appliances!
Bone fractures / crush injuries
▶ Secure appliances against slipping.



Caution

Risk of falling parts due to released screws!
Injury because of falling parts.
▶ Secure component from falling down.



Notice

Risk of falling parts due to released screws!
Damage to other parts of the appliance or at customers home e.g. bottom.
▶ Secure component from falling down.

Prerequisite:

- ✔ Appliance is disconnected from power supply.
- ✔ Appliance is disconnected from water supply.
- ✔ Appliances is freely accessible.
- ✔ [Detergent drawer has been removed. → Page 114](#)
- ✔ Fascia panel has been removed.

4.9.1 Removing drum light

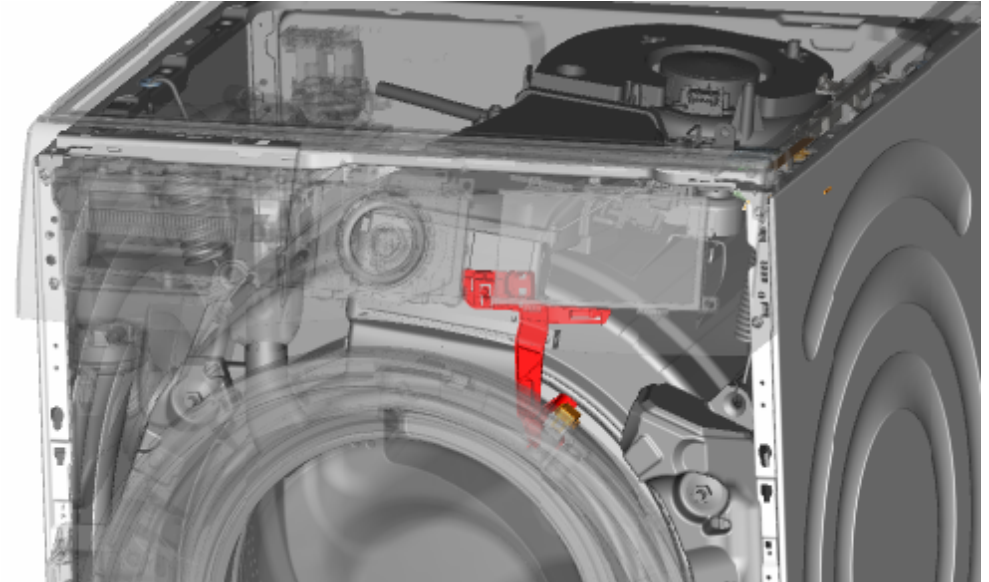

1. Pull drum light holder out of appliance.
2. Disconnect electrical connections.
3. Remove drum light from drum light holder.

4.9.2 Installing drum light



- ▶ Install in reverse order.

4.10 Replacing bottom cover





Fig. 1: Bottom group cover

Prerequisite:

-  Appliance is disconnected from power supply.
-  Appliance is disconnected from water supply.
-  Furniture panel has been removed.

4.10.1 Removing bottom cover

Prerequisite:

-  Appliance is disconnected from power supply.
 -  Appliance is disconnected from water supply.
1. Remove bottom cover.

2. Detach hose from the holder.



3. 1. Unscrew the screw (1).
2. Press retaining point and remove downwards (2).

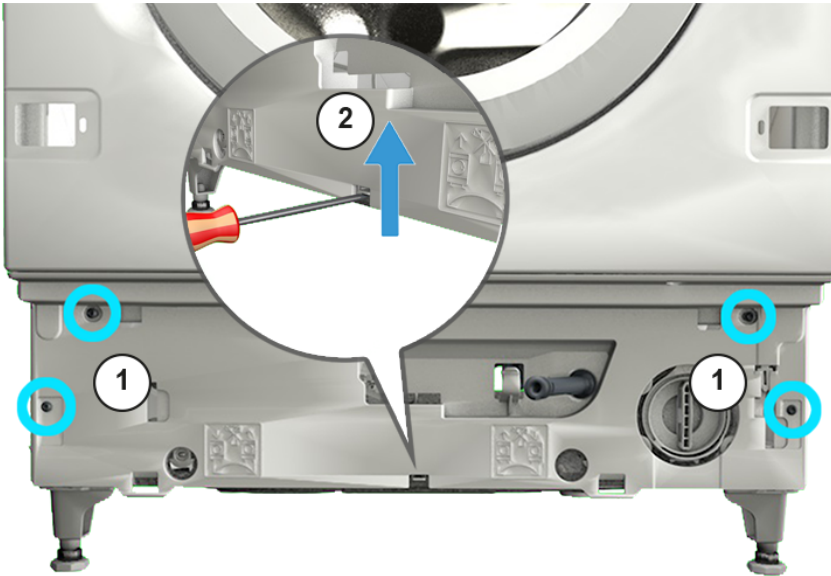

4. Pull bottom group cover and remove forwards.

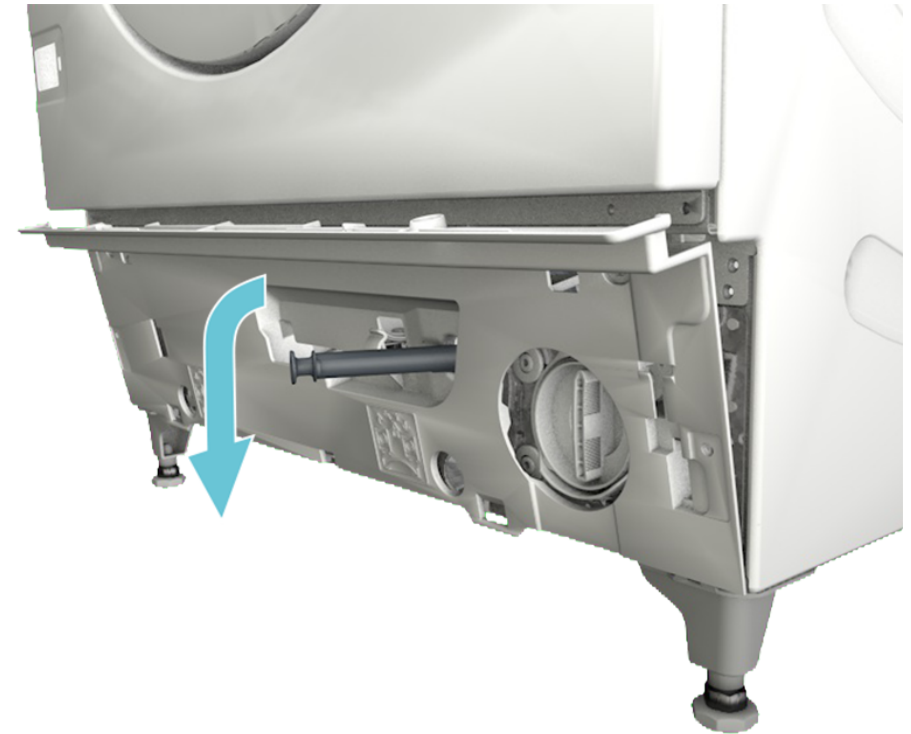

5. Pull hose out of the cover.

4.10.2 Installing the cover

- Install in reverse order.

4.11 Replacing front panel

| | |
|--|--|
|  | ⚠ Caution Sharp housing edges! Cut injuries ▶ Wear protective gloves. |
|--|--|

Prerequisite:

- ✔ Appliance is disconnected from power supply.
- ✔ Appliance is disconnected from water supply.
- ✔ Appliances is freely accessible.
- ✔ [Detergent drawer has been removed. → Page 114](#)
- ✔ Furniture panel has been removed.
- ✔ [Door has been removed. → Page 116](#)
- ✔ Door seal has been removed.

4.11.1 Removing front panel

1. Loosen the retainer on the drum light.

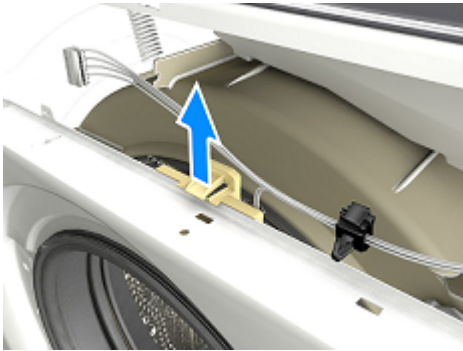

2.

| | |
|---|---|
|  | ⚠ Caution Risk of falling parts due to released screws! Injury because of falling parts. ▶ Secure component from falling down. |
|---|---|

| | |
|---|--|
|  | Notice Risk of falling parts due to released screws! Damage to other parts of the appliance or at customers home e.g. bottom. ▶ Secure component from falling down. |
|---|--|

Loosen the screws in the indicated order.





3. Remove front panel.

4.11.2 Installing front panel

- ▶ Install in reverse order.

Remonditeave - Pesumasin

| | |
|--|------------|
|  Selle dokumendiga seoses | 129 |
| 1.1 Tähtis teave | 129 |
| 1.1.1 Eesmärk..... | 129 |
| 1.2 Sümbolite selgitus | 129 |
| 1.2.1 Ohutasemed..... | 129 |
| 1.2.2 Ohusümbolid | 129 |
| 1.2.3 Hoiatuste struktuur..... | 130 |
| 1.2.4 Üldised sümbolid..... | 130 |
|  Ohutus..... | 131 |
| 2.1 Üldised ohutusjuhised..... | 131 |
| 2.1.1 Kõik kodumasinad..... | 131 |
|  Tööriistad ja abinõud..... | 132 |
|  Remont..... | 133 |
| 4.1 Välispaneeli vahetamine | 133 |
| 4.1.1 Välispaneeli eemaldamine | 133 |
| 4.1.2 Välispaneeli paigaldamine | 134 |
| 4.2 Pesuaine sahtli vahetamine..... | 135 |
| 4.2.1 Pesuaine sahtli eemaldamine | 135 |
| 4.2.2 Pesuaine sahtli paigaldamine | 135 |
| 4.3 Pesuaine sahtli käepideme vahetamine | 136 |
| 4.3.1 Pesuaine sahtli käepideme eemaldamine | 136 |
| 4.3.2 Pesuaine sahtli käepideme paigaldamine | 136 |
| 4.4 Ukse vahetamine..... | 137 |
| 4.4.1 Ukse eemaldamine | 137 |
| 4.4.2 Ukse paigaldamine..... | 137 |
| 4.5 Ukseosade vahetamine..... | 138 |
| 4.5.1 Ukse osade eemaldamine | 138 |
| 4.5.2 Ukse osade paigaldamine | 138 |
| 4.6 Ukse hinge vahetamine..... | 139 |
| 4.6.1 Ukse hinge eemaldamine | 139 |
| 4.6.2 Ukse hinge paigaldamine | 139 |
| 4.7 Ukse tihendi vahetamine..... | 140 |
| 4.7.1 Ukse tihendi eemaldamine..... | 140 |
| 4.7.2 Uksetihendi paigaldamine..... | 141 |

| | |
|--|-----|
| 4.8 Ukseluku vahetamine | 142 |
| 4.8.1 Ukseluku eemaldamine..... | 142 |
| 4.8.2 Ukseluku paigaldamine | 143 |
| 4.9 Trumli valgustuse vahetamine..... | 144 |
| 4.9.1 Trumli valgustuse eemaldamine | 144 |
| 4.9.2 Trumli valgustuse paigaldamine | 144 |
| 4.10 Põhjakatte vahetamine | 145 |
| 4.10.1 Põhjakatte eemaldamine..... | 145 |
| 4.10.2 Katte paigaldamine..... | 146 |
| 4.11 Esipaneeli vahetamine | 147 |
| 4.11.1 Esipaneeli eemaldamine | 147 |
| 4.11.2 Esipaneeli paigaldamine | 148 |

i Selle dokumendiga seoses

1.1 Tähtis teave

1.1.1 Eesmärk

Need remondinõuanded toetavad tarbijat seadmete iseseisval remontimisel vastavalt kehtivale ökodisaini määrusele (03/2021).





Need sisaldavad teavet selle kohta, kuidas vahetada teatud varuosi, samuti hoiatusi ning ohtusid.

Küsimuste korral võtke ühendust meie klienditeenindusega. Meie vastutame kahjustuste eest ainult siis, kui remondinõuandeid on õigesti järgitud.

1.2 Sümbolite selgitus

1.2.1 Ohutasemed

Ohutasemed koosnevad sümbolist ja märksõnast. Märksõna viitab ohu raskusastmele.





| Hoiatustase | Tähendus |
|---|--|
|  OHT | Hoiatusteadete eiramine põhjustab surma või raskeid kehavigastusi. |
|  HOIATUS | Hoiatusteadete eiramine võib põhjustada surma või raskeid kehavigastusi. |
|  ETTEVAATUST! | Hoiatusteadete eiramine võib põhjustada kergeid kehavigastusi. |
|  TÄHELEPANU! | Hoiatusteadete eiramine võib põhjustada varakahju. |

Tabel 1: Ohutasemed



1.2.2 Ohusümbolid

Ohusümbolid on sümboolsed kujutised, mis viitavad ohu laadile.

Selles dokumendis kasutatakse alljärgnevaid ohusümboleid.

| Ohusümbol | Tähendus |
|---|-----------------------------|
|  | Üldine ohuteade |
|  | Elektripingest tingitud oht |
|  | Plahvatusoht |
|  | Lõikeoht |
|  | Muljumisoht |

i Selle dokumendiga seoses

| Ohusümbol | Tähendus |
|--|--|
|  | Kuumadest pindadest tingitud oht |
|  | Tugevast magnetväljast tingitud oht |
|  | Mitteioniseerivast kiirgusest tingitud oht |

Tabel 2: Ohusümbolid

1.2.3 Hoiatuste struktuur

Selles dokumendis olevatel hoiatustel on standardiseeritud väljanägemine ja standardiseeritud struktuur.



| | |
|--|---|
|  | <div style="background-color: red; color: white; padding: 2px; display: inline-block;">⚠ OHT</div> Ohu tüüp ja allikas! Ohu/hoiatuse eiramise võimalikud tagajärjed. ▶ Meetmed ja ettevaatusabinõud ohu vältimiseks. |
|--|---|





Alljärgnevas näiteks on näidatud hoiatust, millega hoiatatakse liikuvatest osadest tingitud elektrilöögiu eest. Nimetatud on meetet ohu vältimiseks.

| | |
|---|--|
|  | <div style="background-color: red; color: white; padding: 2px; display: inline-block;">⚠ OHT</div> Liikuvatest osadest tingitud elektrilöögi oht! Elektrilöögist tingitud surm ▶ Enne remonditöödega alustamist ühendage seadmed elektrivõrgust lahti vähemalt 60 sekundit varem. |
|---|--|

1.2.4 Üldised sümbolid

Selles dokumendis kasutatakse alljärgnevaid üldisi sümboleid.

| Üld. sümbol | Tähendus |
|--|--|
|  | Erinõuande tunnus (tekst ja/või graafik) |
|  | Lihtsa nõuande tunnus (ainult tekst) |
|  | Videojuhendi lingi tunnus |

| Üld. sümbol | Tähendus |
|---|---|
|  | Vajalike tööriistade tunnus |
|  | Vajalike eeltingimuste tunnus |
|  | Seisukorra tunnus (kui..., siis...) |
|  | Tulemuse tunnus |
| [Start] | Klahvi või nupu tunnus |
| [00123456] | Materjalinumbr tunnus |
| Olek | Kuvatava teksti/akna tunnus (seadme ekraanil) |

Tabel 3: Üldised sümbolid

2.1 Üldised ohutusjuhised

2.1.1 Kõik kodumasinad

Liikuvatest osadest tingitud elektrilöögi oht!

- Elektriliste osade remondil tehtud vead võivad põhjustada elektrilööki!
- Lahutage seade vooluvõrgust vähemalt 60 sekundit enne tööle hakkamist.
- Pärast remonti peab olema tehtud ohutuskatse vastavalt standardile VDE 0701 või riiklikele määrustele.

Teravatest servadest tingitud vigastusoht!

- Kandke kaitsekindaid.

Rasketest ja liikuvatest osadest tingitud muljumisoht remondi-, puhastustööde, tõrkeotsingu ja hoolduse käigus

- Kandke turvakingi.
- Kinnitage rasked osad allakukkumise vastu.
- Ärge toppige kehaosi liikuvate osade vahele.







Oht seadme ohutusele/talitlusele!





- Kasutage ainult originaalvaruosasid.

Elektrostaatiliselt tundlike osade (ESD) kahjustamise oht!





- Ärge puudutage moduleid, kaasa arvatud ühendusi ega transportöörlinte.

Tööriistad ja abinõud

| Määramine | Üksikasjad | Kujutised |
|--|--|--|
| Abitööriist [15000155] | Tööriist plastosade lahtitegemiseks |  |
| Tähtotsikuga T20 kruvikeeraja koos puurimisaguga [00340764] | 100 mm, splindiga poltidele |  |
| Pöördemomendi mutrivõti [15000441] | Pöördemomendi mutrivõti 20-100 Nm | |
| Lapik kruvikeeraja [00340854] | Tera 3,5 mm x 0,6 mm x 100 mm, kaitseisolatsioon 1000 V AC |  |
| Lapik kruvikeeraja [00340855] | Tera 5,5 mm x 1,0 mm x 125 mm, kaitseisolatsioon 1000 V AC |  |
| Peeneotsalsed tangid, nurga all [00341269] | Pikkus 200 mm |  |
| Külg-lõiketangid [00342182] | Pikkus: 200 mm |  |

| Määramine | Üksikasjad | Kujutised |
|---------------------------------------|------------------------------|---|
| Kombineeritud mutrivõti [00340811] | Mutrivõtme suurus 10°mm, M6 |  |
| Combination wrench [00340814] | Mutrivõtme suurus 13°mm, M8 |  |
| Kombineeritud mutrivõti [00340817] | Mutrivõtme suurus 17 mm, M10 |  |
| Kombineeritud mutrivõti [15000459] | Mutrivõtme suurus 16°mm, M10 |  |

4.1 Välispaneeli vahetamine

| | |
|--|--|
|  | ⚠ ETTEVAATUST! Teravad korpuse osad! Lõikehaavad ▶ Kandke kaitsekindaid. |
|  | ⚠ HOIATUS Viltuses asendis seadmete libisemisoht! Luumurrud/muljumised ▶ Kindlustage seadmed libisemise vastu. |
|  | ⚠ ETTEVAATUST! Lahtikeeratud poltidest tingitud osade kukumisoht! Kukkuvatest osadest tingitud vigastused. ▶ Kinnitage osa allakukkumise vastu. |
|  | TÄHELEPANU! Lahtikeeratud poltidest tingitud osade kukumisoht! Seadme teiste osade kahjustused või klientide vara kahjustused. ▶ Kinnitage osa allakukkumise vastu. |

Nõue:

- ✓ Seade on toitest lahutatud.
- ✓ Seade on veeühendusest lahutatud.
- ✓ Seadmetele pääseb vabalt ligi.
- ✓ [Pesuaine sahtel eemaldatud.→135](#)

4.1.1 Välispaneeli eemaldamine

1. Vabastage kinnituselement (1).
2. Eemaldage kate (2).

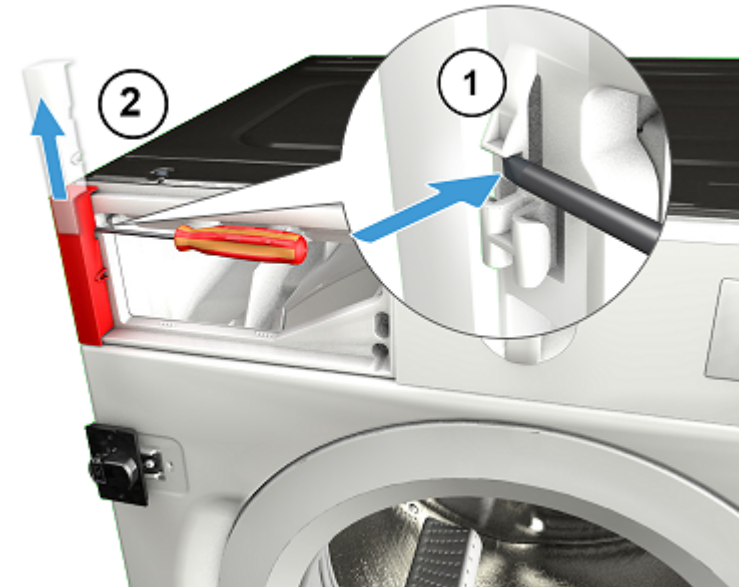

2. Eemaldage poldid.



3. 1. Vabastage kinnituselemendid (1, 2).
2. Tõmmake välispaneeli ettesuunas (3).

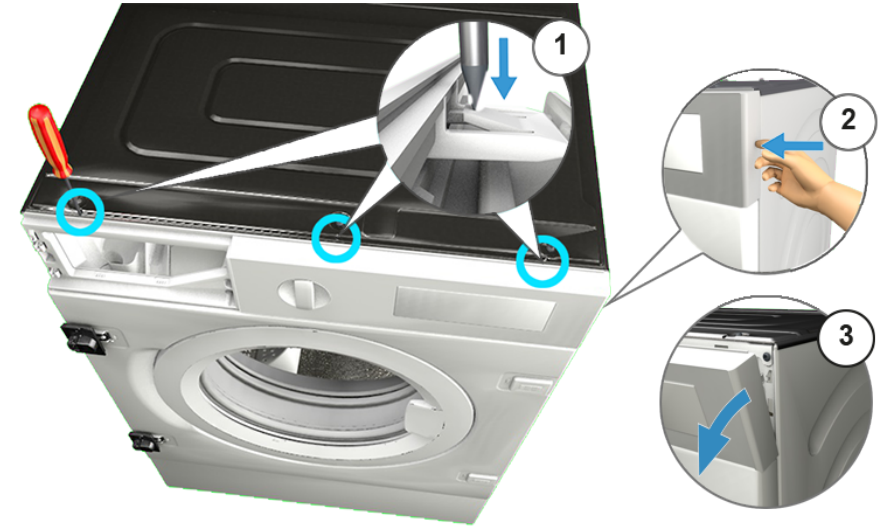

4. Eemaldage välispaneel.

4.1.2 Välispaneeli paigaldamine

► Paigaldage vastupidises järjekorras.

4.2 Pesuaine sahtli vahetamine

Nõue:

- ✓ Seade on toitest lahutatud.
- ✓ Seade on veeühendusest lahutatud.

4.2.1 Pesuaine sahtli eemaldamine

1. Tõmmake pesuaine sahtel välja.
2. 1. Suru kasseti (1) alla.
2. Eemaldage pesuaine sahtel (2).

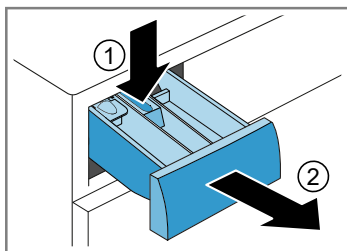

4.2.2 Pesuaine sahtli paigaldamine

- ▶ Paigaldage vastupidises järjekorras.

4.3 Pesuaine sahtli käepideme vahetamine

Nõue:

- ✓ Seade on toitest lahutatud.
- ✓ Seade on veeühendusest lahutatud.
- ✓ [Pesuaine sahtel eemaldatud.](#)→135

4.3.1 Pesuaine sahtli käepideme eemaldamine

1. Vabastage kinnituselemendid.

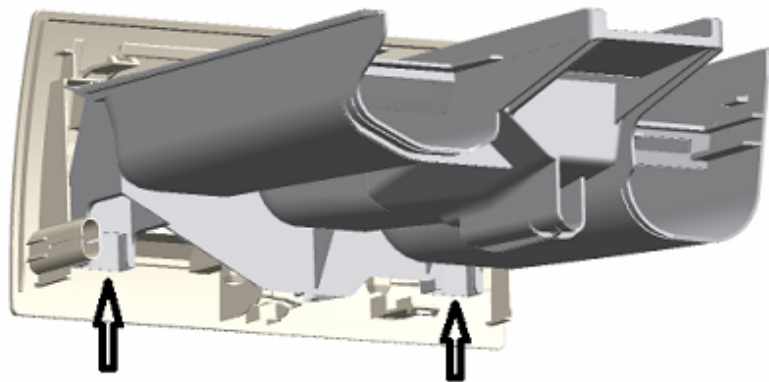

2. Eemaldage pesuaine sahtli käepide.

4.3.2 Pesuaine sahtli käepideme paigaldamine

- ▶ Paigaldage vastupidises järjekorras.

4.4 Ukse vahetamine

| | |
|--|--|
|  | ⚠ ETTEVAATUST! Avatud liigendi piirkond! Sõrmede muljumine/kinnijäämine <ul style="list-style-type: none">▶ Ärge pistke käsi liigendi piirkonda.▶ Kandke kaitsekindaid. |
|--|--|

Nõue:

- ✔ Seade on toitest lahutatud.
- ✔ Seade on veeühendusest lahutatud.
- ✔ Uks on avatud.
- ✔ Mööblipaneel on eemaldatud.

4.4.1 Ukse eemaldamine

1.

| | |
|---|---|
|  | TÄHELEPANU! Lahtikeeratud poltidest tingitud osade kukumisoht! Seadme teiste osade kahjustused või klientide vara kahjustused. <ul style="list-style-type: none">▶ Kinnitage osa allakukkumise vastu. |
|---|---|

| | |
|---|---|
|  | ⚠ ETTEVAATUST! Lahtikeeratud poltidest tingitud osade kukumisoht! Kukkuvatest osadest tingitud vigastused. <ul style="list-style-type: none">▶ Kinnitage osa allakukkumise vastu. |
|---|---|

Eemaldage kruvid (1).

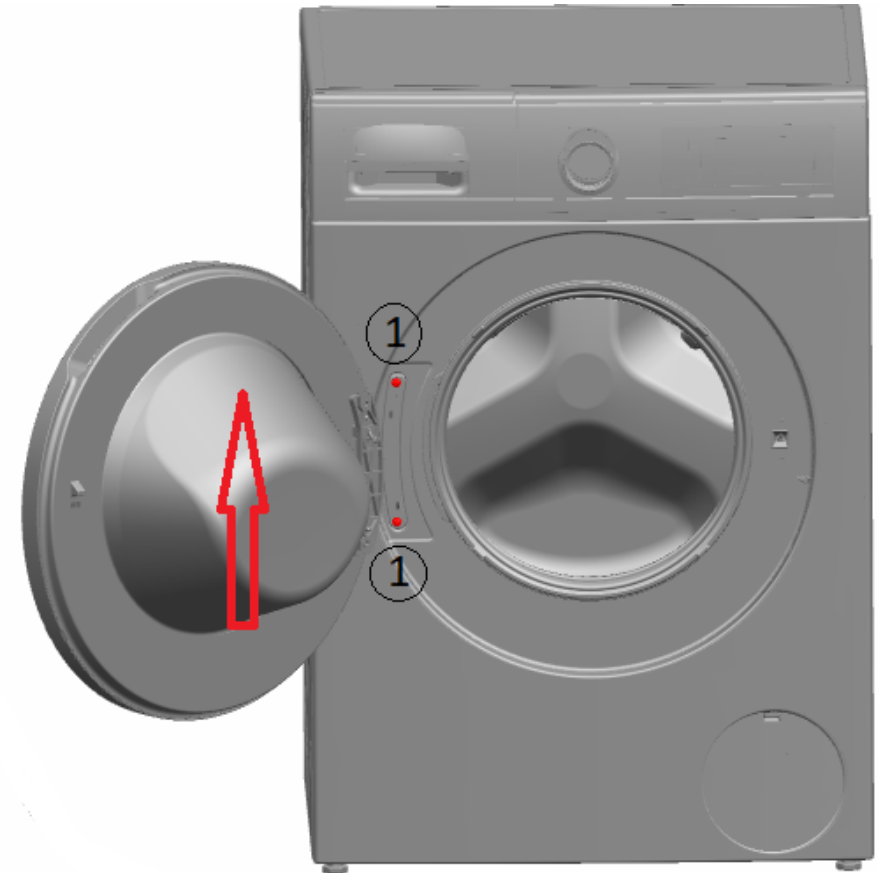

2. Eemaldage uks ülessuunas.

4.4.2 Ukse paigaldamine

- ▶ Paigaldage vastupidises järjekorras.

4.5 Ukseosade vahetamine



⚠ ETTEVAATUST!

Avatud liigendi piirkond!

Sõrmede muljumine/kinnijäämine

- ▶ Ärge pistke käsi liigendi piirkonda.
- ▶ Kandke kaitsekindaid.

Nõue:

- ✔ Seade on toitest lahutatud.
- ✔ Seade on veeühendusest lahutatud.
- ✔ Mööblipaneel on eemaldatud.
- ✔ [Uks on eemaldatud.→137](#)

4.5.1 Ukse osade eemaldamine

- ▶ Võtke uks lahti seestpoolt väljapoole.

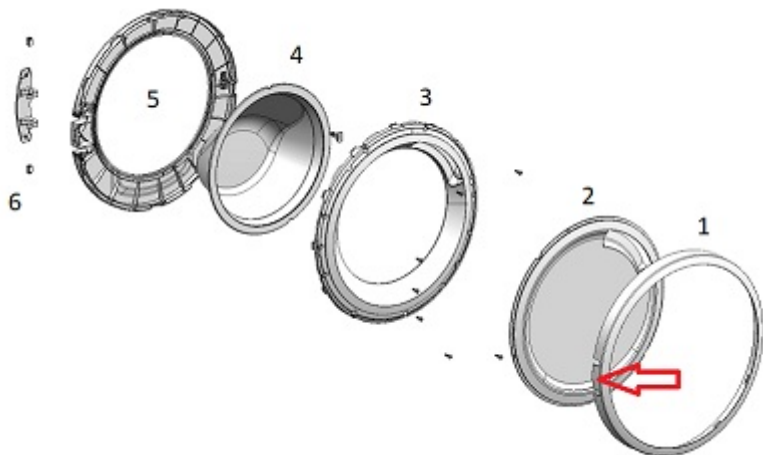

4.5.2 Ukse osade paigaldamine

- ▶ Paigaldage vastupidises järjekorras.

4.6 Ukse hinge vahetamine



⚠ ETTEVAATUST!

Avatud liigendi piirkond!

Sõrmede muljumine/kinnijäämine

- ▶ Ärge pistke käsi liigendi piirkonda.
- ▶ Kandke kaitsekindaid.

Nõue:

- ✔ Seade on toitest lahutatud.
- ✔ Seade on veeühendusest lahutatud.

4.6.1 Ukse hinge eemaldamine

1. Vabastage kaks kruvi.
2. Eemaldage uks.
3. Võtke uks lahti seestpoolt väljapoole.

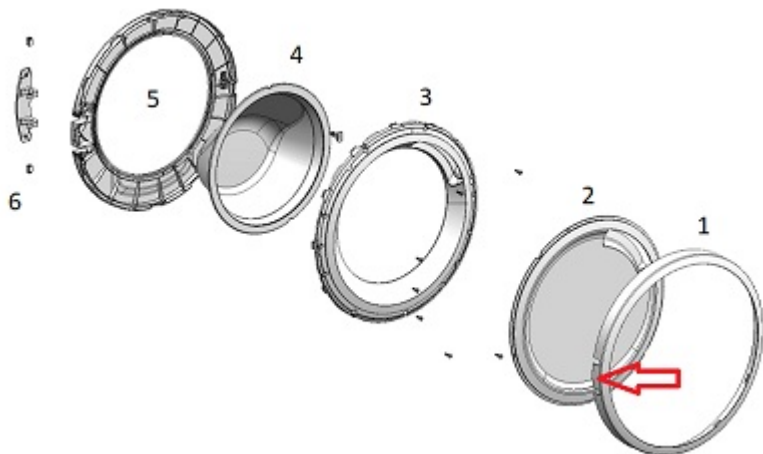



4. Eemaldage ukse hing.

4.6.2 Ukse hinge paigaldamine

- ▶ Paigaldage vastupidises järjekorras.

4.7 Ukse tihendi vahetamine

| | |
|--|---|
|  | ⚠ ETTEVAATUST! Teravad korpuse osad! Lõikehaavad ▶ Kandke kaitsekindaid. |
|--|---|

| | |
|--|--|
|  | ⚠ ETTEVAATUST! Lahtikeeratud poldidest tingitud osade kukumisoht! Kukkuvatest osadest tingitud vigastused. ▶ Kinnitage osa allakukkumise vastu. |
|--|--|

| | |
|--|--|
|  | TÄHELEPANU! Lahtikeeratud poldidest tingitud osade kukumisoht! Seadme teiste osade kahjustused või klientide vara kahjustused. ▶ Kinnitage osa allakukkumise vastu. |
|--|--|

Nõue:

- ✔ Seade on toitest lahutatud.
- ✔ Seade on veeühendusest lahutatud.
- ✔ Seadmetele pääseb vabalt ligi.
- ✔ [Pesuaine sahtel eemaldatud.→135](#)
- ✔ Välispaneel on eemaldatud.
- ✔ [Uks on eemaldatud.→137](#)
- ✔ [Põhjake on eemaldatud.→145](#)

4.7.1 Ukse tihendi eemaldamine

1. Lõdvendage trumli valgustusel olevat fiksaatorit.

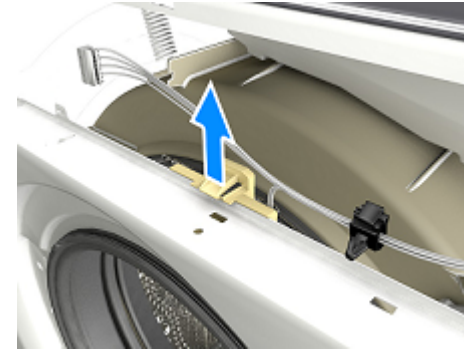

2.

| | |
|---|---|
|  | TÄHELEPANU! Pinna kahjustamise oht! Valede tööriistadega võib seadme pind saada kriimustada. ▶ Kasutage pingutusrõnga vahetamisel ainult plastikust tööriistu. |
|---|---|

Eemaldage pingutusrõngas muhvist plastikust tööriista abil.

3. Eemaldage esipaneeli tihend.
4. Vabastage kaabliühendus ukسلukult.

5. Lõdvendage polte näidatud järjekorras.



6. Eemaldage esipaneel.

7. Ühendage kõik voolikuühendused lahti.

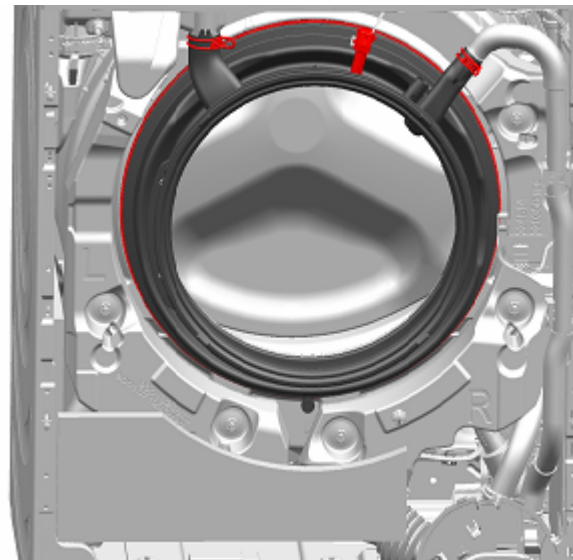

8. Eemaldage uksetihend.

4.7.2 Uksetihendi paigaldamine

- ▶ Paigaldage vastupidises järjekorras.

4.8 Ukseluku vahetamine

Tootjana oleme kohustatud tagama tarbijatele ukseluku varuosad, sealhulgas remontimisjuhendi, vastavalt direktiivile (EL) 2019/2023. Siiski soovime viidata sellele, et pärast ukseluku vahetamist on enne seadme kasutuselevõttu vajalik lasta kvalifitseeritud elektrikul teha elektrotehniline ohutuskatse. See isik peab olema riiklike seaduste, määruste ja standardite järgi tõendatult koolitatud.

| | |
|--|--|
|  | OHT Liikuvatest osadest tingitud elektrilöögi oht! Kui remonditööd on valesti tehtud, esineb elektrilöögist tingitud eluohu. <ul style="list-style-type: none">▶ Elektrilisi osasid peavad parandama kvalifitseeritud elektrikud.▶ Pärast remonti peab olema tehtud ohutuskatse vastavalt standardile VDE 0701 või riiklikele määrustele. |
|--|--|

| | |
|--|--|
|  | ETTEVAATUST! Teravad korpuse osad! Lõikehaavad <ul style="list-style-type: none">▶ Kandke kaitsekindaid. |
|--|--|

| | |
|--|--|
|  | HOIATUS Viltuses asendis seadmete libisemisoht! Luumurrud/muljumised <ul style="list-style-type: none">▶ Kindlustage seadmed libisemise vastu. |
|--|--|

| | |
|---|--|
|  | ETTEVAATUST! Lahtikeeratud poltidest tingitud osade kukkumisoht! Kukkuvatest osadest tingitud vigastused. <ul style="list-style-type: none">▶ Kinnitage osa allakukkumise vastu. |
|---|--|

| | |
|--|--|
|  | TÄHELEPANU! Lahtikeeratud poltidest tingitud osade kukkumisoht! Seadme teiste osade kahjustused või klientide vara kahjustused. <ul style="list-style-type: none">▶ Kinnitage osa allakukkumise vastu. |
|--|--|

Nõue:

- ✓ Seade on toitest lahutatud.
- ✓ Seade on veeühendusest lahutatud.
- ✓ Seadmetele pääseb vabalt ligi.

- ✓ Mööblipaneel on eemaldatud.
- ✓ Välispaneel on eemaldatud.
- ✓ [Uks on eemaldatud. → 137](#)
- ✓ Pingutusrõngas on eemaldatud.
- ✓ Esipaneel on eemaldatud.
- ✓ Uksetihend on eemaldatud.

4.8.1 Ukseluku eemaldamine

1. Ühendage ukseluku pistik lahti.
2. Vabastage ukselukk.



3. Eemaldage ukselukk.

4.8.2 Ukseluku paigaldamine

Ukseluk peab olema õiges asendis, et tagada seadme avariiuukse avanemise funktsioon.

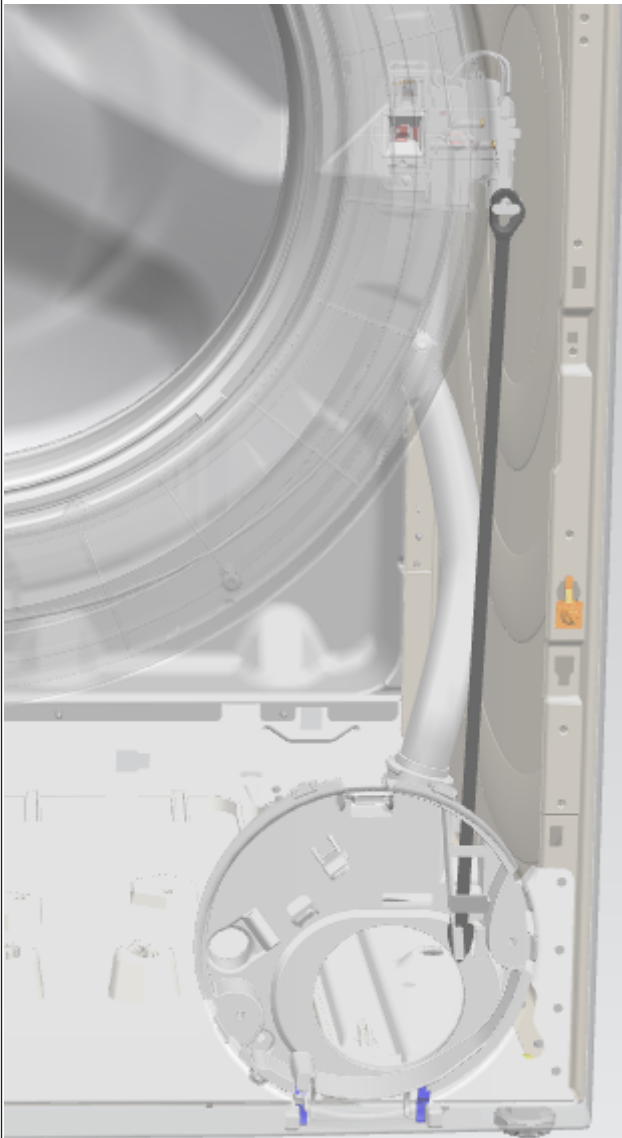

- ▶ Paigaldage vastupidises järjekorras.

4.9 Trumli valgustuse vahetamine



⚠ ETTEVAATUST!

Teravad korpuse osad!
Lõikehaavad
▶ Kandke kaitsekindaid.



⚠ HOIATUS

Viltuses asendis seadmete libisemisoht!
Luumurrud/muljumised
▶ Kindlustage seadmed libisemise vastu.



⚠ ETTEVAATUST!

Lahtikeeratud poltides tingitud osade kukkumisoht!
Kukkuvatest osadest tingitud vigastused.
▶ Kinnitage osa allakukkumise vastu.



TÄHELEPANU!

Lahtikeeratud poltides tingitud osade kukkumisoht!
Seadme teiste osade kahjustused või klientide vara kahjustused.
▶ Kinnitage osa allakukkumise vastu.

Nõue:

- ✔ Seade on toitest lahutatud.
- ✔ Seade on veeühendusest lahutatud.
- ✔ Seadmetele pääseb vabalt ligi.
- ✔ [Pesuaine sahtel eemaldatud.→135](#)
- ✔ Välispaneel on eemaldatud.

4.9.1 Trumli valgustuse eemaldamine

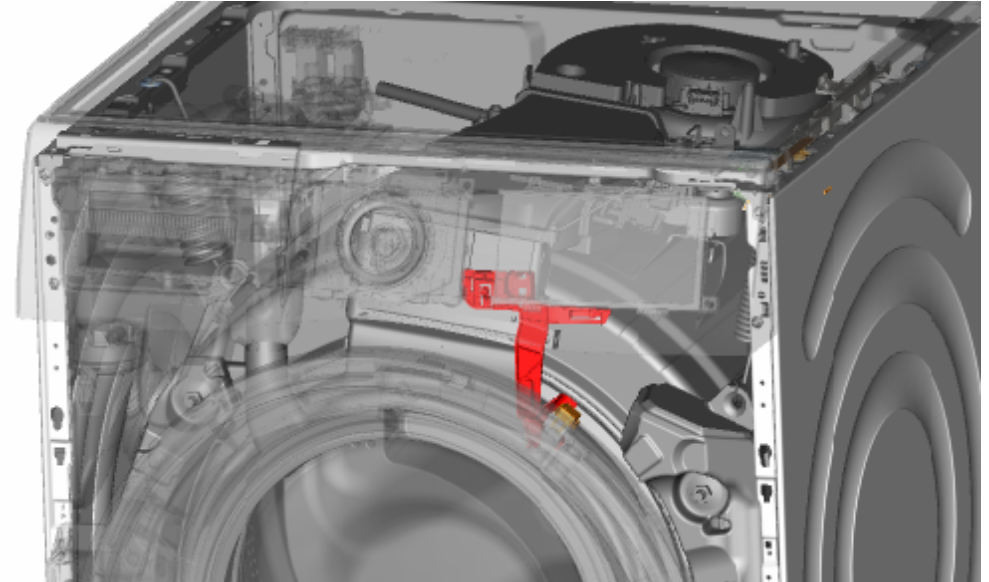

1. Tõmmake trumli valgustuse hoidik seadmest välja.
2. Ühendage elektriühendused lahti.
3. Eemaldage trumli valgustus trumli valgustuse hoidikust.

4.9.2 Trumli valgustuse paigaldamine

- ▶ Paigaldage vastupidises järjekorras.

4.10 Põhjakatte vahetamine



Joonis 1: Põhja multikate

Nõue:

- ✓ Seade on toitest lahutatud.
- ✓ Seade on veeühendusest lahutatud.
- ✓ Mööblipaneel on eemaldatud.

4.10.1 Põhjakatte eemaldamine

Nõue:

- ✓ Seade on toitest lahutatud.
- ✓ Seade on veeühendusest lahutatud.

1. Eemaldage põhjakatte.

2. Vabastage voolik hoidikust.



Remont

3. 1. Keerake polt lahti (1).
2. Suruge tugipunkti ja eemaldage allasuunas (2).

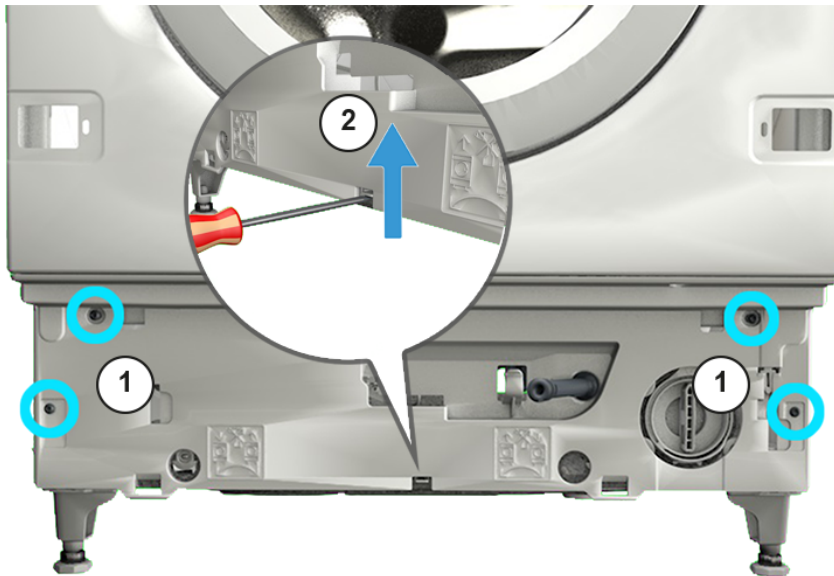

4. Suruge põhja multikatet ja eemaldage see ettesuunas liigutades.

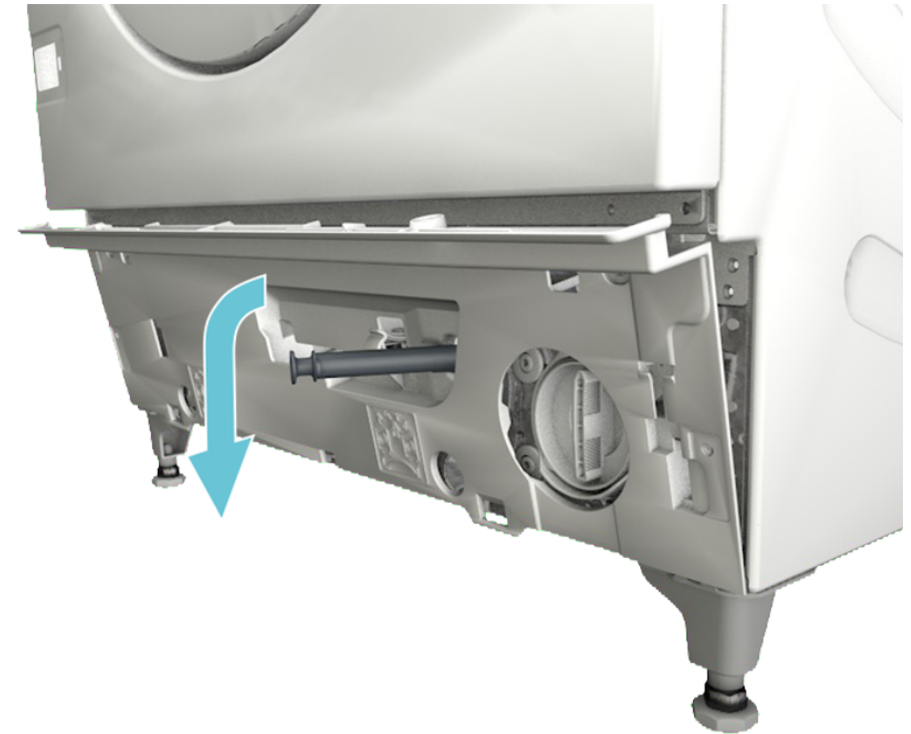

5. Tõmmake voolik kattest välja.

4.10.2 Katte paigaldamine

- Paigaldage vastupidises järjekorras.

4.11 Esipaneeli vahetamine



⚠ ETTEVAATUST!

Teravad korpuse osad!

- Lõikehaavad
- ▶ Kandke kaitsekindaid.

Nõue:

- ✓ Seade on toitest lahutatud.
- ✓ Seade on veeühendusest lahutatud.
- ✓ Seadmetele pääseb vabalt ligi.
- ✓ [Pesuaine sahtel eemaldatud. → 135](#)
- ✓ Mööblipaneel on eemaldatud.
- ✓ [Uks on eemaldatud. → 137](#)
- ✓ Uksetihend on eemaldatud.

4.11.1 Esipaneeli eemaldamine

1. Lõdvendage trumli valgustusel olevat fiksaatorit.

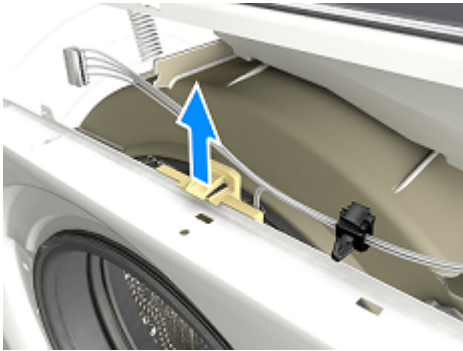

- 2.



⚠ ETTEVAATUST!

Lahtikeeratud poltdest tingitud osade kukumisoht!

- Kukkuvatest osadest tingitud vigastused.
- ▶ Kinnitage osa allakukkumise vastu.



TÄHELEPANU!

Lahtikeeratud poltdest tingitud osade kukumisoht!

- Seadme teiste osade kahjustused või klientide vara kahjustused.
- ▶ Kinnitage osa allakukkumise vastu.

Lõdvendage polte näidatud järjekorras.



3. Eemaldage esipaneel.

4.11.2 Esipaneeli paigaldamine

- ▶ Paigaldage vastupidises järjekorras.

Korjausvinkit - Pyykinpesukone

Tämä asiakirja 150

| | | |
|-------|---------------------------|-----|
| 1.1 | Tärkeitä tietoja..... | 150 |
| 1.1.1 | Tarkoitus | 150 |
| 1.2 | Symboleiden merkitys..... | 150 |
| 1.2.1 | Vaaratasot..... | 150 |
| 1.2.2 | Varoitusmerkit..... | 150 |
| 1.2.3 | Varoitusten rakenne | 151 |
| 1.2.4 | Yleiset symbolit..... | 151 |

Turvallisuus..... 152

| | | |
|-------|---------------------------------|-----|
| 2.1 | Yleiset turvallisuusohjeet..... | 152 |
| 2.1.1 | Kaikki kotitalouskoneet..... | 152 |

Työkalut ja apuvälineet..... 153

Korjaus..... 154

| | | |
|-------|--|-----|
| 4.1 | Ohjauspaneelin vaihtaminen | 154 |
| 4.1.1 | Ohjauspaneelin poistaminen..... | 154 |
| 4.1.2 | Ohjauspaneelin asentaminen..... | 155 |
| 4.2 | Pesuainelokeron vaihtaminen..... | 156 |
| 4.2.1 | Pesuainelokeron poistaminen | 156 |
| 4.2.2 | Pesuainelokeron asentaminen | 156 |
| 4.3 | Pesuainelokeron kahvan vaihtaminen | 157 |
| 4.3.1 | Pesuainelokeron kahvan poistaminen | 157 |
| 4.3.2 | Pesuainelokeron kahvan asentaminen | 157 |
| 4.4 | Luukun vaihtaminen..... | 158 |
| 4.4.1 | Luukun poistaminen | 158 |
| 4.4.2 | Luukun asennus | 158 |
| 4.5 | Luukun komponenttien vaihtaminen..... | 159 |
| 4.5.1 | Luukun komponenttien poistaminen | 159 |
| 4.5.2 | Luukun komponenttien asennus..... | 159 |
| 4.6 | Luukun saranan vaihtaminen | 160 |
| 4.6.1 | Luukun saranan poistaminen | 160 |
| 4.6.2 | Luukun saranan asennus | 160 |
| 4.7 | Luukun tiivisteiden vaihtaminen..... | 161 |
| 4.7.1 | Luukun tiivisteiden poistaminen | 161 |
| 4.7.2 | Luukun tiivisteiden asennus | 162 |

| | | |
|--------|-------------------------------------|-----|
| 4.8 | Luukun lukitsimen vaihtaminen | 163 |
| 4.8.1 | Luukun lukitsimen poistaminen..... | 163 |
| 4.8.2 | Luukun lukitsimen asennus | 164 |
| 4.9 | Rummun lampun vaihtaminen..... | 165 |
| 4.9.1 | Rummun lampun poistaminen | 165 |
| 4.9.2 | Rummun lampun asennus | 165 |
| 4.10 | Alaosan suojuksen vaihtaminen | 166 |
| 4.10.1 | Alaosan suojuksen poistaminen | 166 |
| 4.10.2 | Suojuksen asennus | 167 |
| 4.11 | Etupaneelin vaihtaminen | 168 |
| 4.11.1 | Etupaneelin poistaminen..... | 168 |
| 4.11.2 | Etupaneelin asentaminen..... | 169 |

Tämä asiakirja

1.1 Tärkeitä tietoja

1.1.1 Tarkoitus

Näiden korjausohjeiden tarkoituksena on auttaa kuluttajaa korjaamaan laitteita itse ekologista suunnittelua koskevan asetuksen (päivitys 03/2021) mukaisesti.



Ne sisältävät tietoja siitä, miten määrätyt varaosat voidaan vaihtaa. Lisäksi niihin sisältyy tietoja varoituksista ja riskeistä.

Ota yhteyttä huoltopalveluun, jos sinulla on kysyttävää. Vastamme vahingoista vain, jos korjausohjeita on noudatettu oikein.

1.2 Symboleiden merkitys

1.2.1 Vaaratasot

Varoitustasot koostuvat symbolista ja huomiosanasta. Huomiosanat ilmoittava vaaran vakavuuden.

| Varoitustaso | Merkitys |
|---|--|
|  VAARA | Varoituksen laiminlyönti johtaa kuolemaan tai vakaviin loukkaantumisiin. |
|  VAROITUS | Varoituksen laiminlyönti voi johtaa kuolemaan tai vakaviin loukkaantumisiin. |
|  HUOMAA | Varoituksen laiminlyönti voi johtaa lieviin loukkaantumisiin. |
| HUOMIO! | Varoituksen laiminlyönti voi johtaa omaisuusvahinkoihin. |

Taulukko 1: Vaaratasot

1.2.2 Varoitusmerkit

Varoitusmerkit ovat symboleita sisältäviä esityksiä, jotka osoittavat vaaran tyyppin.

Tässä asiakirjassa käytetään seuraavia varoitusmerkkejä:

| Varoitusmerkki | Merkitys |
|---|-----------------------------------|
|  | Yleinen varoitus |
|  | Sähköjännitteestä aiheutuva vaara |
|  | Räjähdysvaara |
|  | Viiltohaavojen vaara |
|  | Murskautumisen vaara |

Tämä asiakirja

| Varoitusmerkki | Merkitys |
|--|--|
|  | Kuumista pinnoista aiheutuva vaara |
|  | Voimakkaasta magneettikentästä aiheutuva vaara |
|  | Ionisoimattomasta säteilystä aiheutuva vaara |

Taulukko 2: Varoitusmerkit

1.2.3 Varoitusten rakenne

Tämän asiakirjan sisältämällä varoituksilla on standardoitu ulkonäkö ja rakenne.



| | |
|--|--|
|  | <div style="background-color: red; color: white; padding: 2px; text-align: center;"> VAARA</div> <p>Vaaran tyyppi ja lähde! Vaaran/varoituksen laiminlyönnistä mahdollisesti aiheutuvat seuraukset.</p> <ul style="list-style-type: none">▶ Vaaran ehkäisemiseen liittyvät toimenpiteet ja kiellot. |
|--|--|

Seuraavassa esimerkissä näytetään varoitus, joka varoittaa jännitteisten osien aiheuttamasta sähköiskusta. Vaaran välttämiseksi suoritettava toimenpide mainitaan.

| | |
|---|---|
|  | <div style="background-color: red; color: white; padding: 2px; text-align: center;"> VAARA</div> <p>Jännitteisten osien aiheuttama sähköiskun vaara! Sähköiskun aiheuttama kuolema</p> <ul style="list-style-type: none">▶ Erotta laitteet sähkövirrasta vähintään 60 sekuntia ennen korjaustöiden aloittamista. |
|---|---|

1.2.4 Yleiset symbolit

Tässä asiakirjassa käytetään seuraavia yleisiä symboleja:

| Yl. symboli | Merkitys |
|--|---|
|  | Erikoisohjeen tunniste (teksti ja/tai kaavio) |
|  | Yksinkertaisen ohjeen tunniste (vain teksti) |

| Yl. symboli | Merkitys |
|---|---|
|  | Video-opetusohjelmaan johtavan linkin tunniste |
|  | Tarvittavien työkalujen tunniste |
|  | Tarvittavien edellytysten tunniste |
|  | Ehdon (jos ..., sitten ...) tunniste |
|  | Tuloksen tunniste |
|  | Näppäimen tai painikkeen tunniste |
|  | Materiaalinumeron tunniste |
|  | Näytetyn tekstin/ikkunan (laitteen näytössä) tunniste |

Taulukko 3: Yleiset symbolit

2.1 Yleiset turvallisuusohjeet

2.1.1 Kaikki kotitalouskoneet

Jännitteisten osien aiheuttama sähköiskun vaara!

- Virheet sähkökomponentteja sisältävissä korjauksissa voivat johtaa sähköiskuun!
- Kytke kone irti verkkovirrasta vähintään 60 sekuntia ennen töiden aloittamista.
- Pyydä korjauksen jälkeen suorittamaan VDE 0701 -säädöksen tai maakohtaisten säädösten mukainen turvallisuustesti.

Terävistä reunoista aiheutuva loukkaantumisvaara!

- Käytä suojakäsineitä.

Painavista ja liikkuvista komponenteista aiheutuva murskautumisen riski korjauksen, kunnossapidon, vianetsinnän ja huollon aikana

- Käytä suojakenkiä.
- Estä painavien komponenttien putoaminen.
- Älä koske liikkuviin komponentteihin.







Laitteen turvallisuudelle/toiminnalle aiheutuva riski!





- Käytä vain alkuperäisiä varaosia.

Staattiselle sähkölle herkkien komponenttien (ESDS) vaurioitumisen riski!





- Älä koske moduuleihin, liitännät ja johdinreitit mukaan luettuna.

Työkalut ja apuvälineet

| Nimitys | Yksityiskohdat | Kuvat |
|---|---|--|
| Lisätyökalu [15000155] | Työkalu, jota käytetään muoviosien irrottamiseen |  |
| Torx T20 -ruuvimeisseli, reiällinen [00340764] | 100 mm, ruuveille lukituksella |  |
| Momenttiavain [15000441] | Momenttiavain 20 - 100 Nm | |
| Uraruuvimeisseli [00340854] | Terä 3,5 mm x 0,6 mm x 100 mm, suojaeristys 1000 V AC |  |
| Uraruuvimeisseli [00340855] | Terä 5,5 mm x 1,0 mm x 125 mm, suojaeristys 1000 V AC |  |
| Nokkapihdit, taivutetut [00341269] | Pituus 200 mm |  |
| Sivuleikkurit [00342182] | Pituus: 200 mm |  |

| Nimitys | Yksityiskohdat | Kuvat |
|--------------------------------------|-----------------------------------|---|
| Yhdistelmä kiintoavain [00340811] | Avainväli 10 ^o mm, M6 |  |
| Combination wrench [00340814] | Avainväli 13 ^o mm, M8 |  |
| Yhdistelmä kiintoavain [00340817] | Avainväli 17 mm, M10 |  |
| Yhdistelmä kiintoavain [15000459] | Avainväli 16 ^o mm, M10 |  |

4.1 Ohjauspaneelin vaihtaminen

| | |
|--|---|
|  | ⚠ HUOMAA Terävät kotelon reunat! Viiltovammat ▶ Käytä suojakäsineitä. |
|  | ⚠ VAROITUS Kallistetun koneen luiskahtaminen! Luunmurtumat/murskavammat ▶ Estä koneiden luiskahtaminen. |
|  | ⚠ HUOMAA Ruuvien avaamisesta aiheutuva osien putoamisen riski! Loukkaantuminen putoavien osien vuoksi. ▶ Estä komponentin putoaminen. |
|  | ⚠ HUOMIO! Ruuvien avaamisesta aiheutuva osien putoamisen riski! Vauriot koneen muille osille tai asiakkaan kodille, esim. lattia. ▶ Estä komponentin putoaminen. |

Vaatus:

- ✓ Kone on erotettu teholähteestä.
- ✓ Kone on erotettu vedenjakelusta.
- ✓ Koneeseen on vapaa pääsy.
- ✓ [Pesuainelokero on poistettu.→156](#)

4.1.1 Ohjauspaneelin poistaminen

1. Vapauta lukitusosa (1).
2. Poista suojus (2).

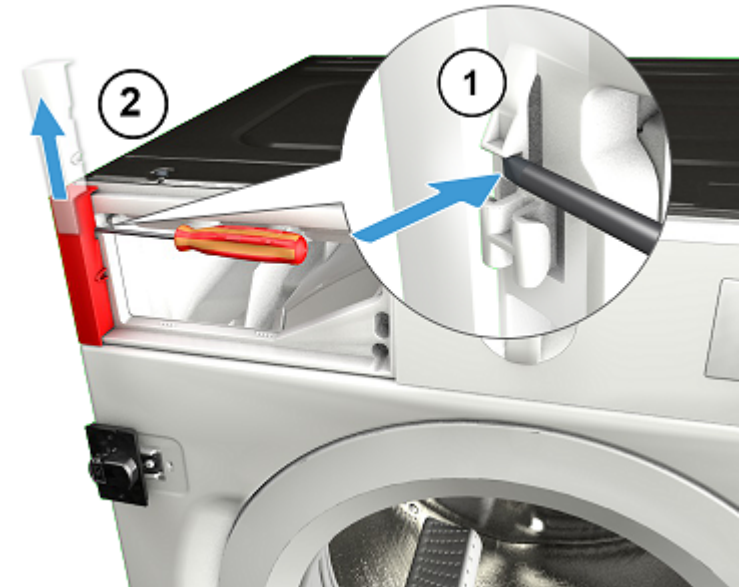

2. Poista ruuvit.



3. 1. Vapauta lukitusosat (1, 2).
2. Vedä ohjauspaneeli eteen (3).

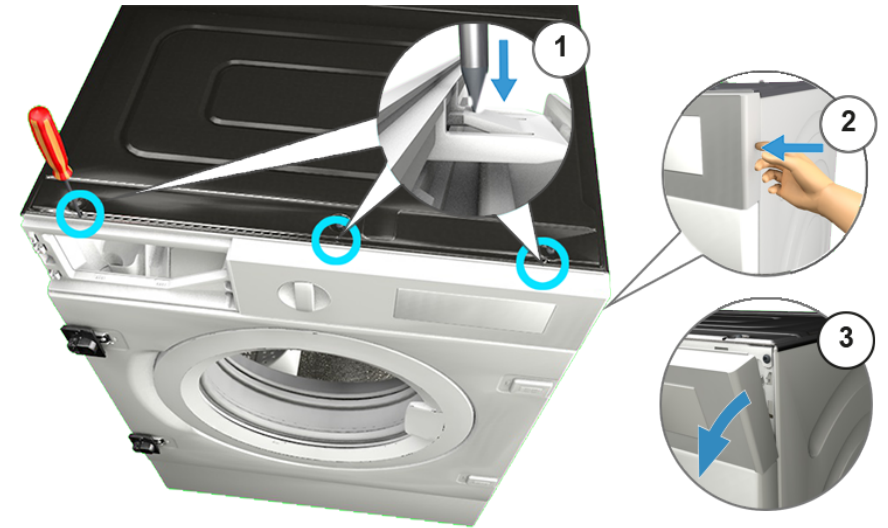

4. Poista ohjauspaneeli.

4.1.2 Ohjauspaneelin asentaminen

► Asenna vastakkaisessa järjestyksessä.

4.2 Pesuainelokeron vaihtaminen

Vaatus:

- ✓ Kone on erotettu teholähteestä.
- ✓ Kone on erotettu vedenjakelusta.

4.2.1 Pesuainelokeron poistaminen

1. Vedä pesuainelokero ulos.
2. 1. Paina liitintä sisään (1).
2. Poista pesuainelokero (2).

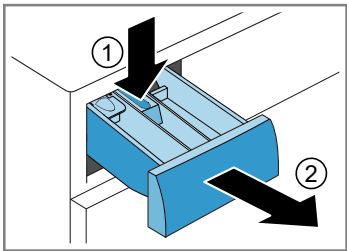

4.2.2 Pesuainelokeron asentaminen

- ▶ Asenna vastakkaisessa järjestyksessä.

4.3 Pesuainelokeron kahvan vaihtaminen

Vaatus:

- ✓ Kone on erotettu tehölähteestä.
- ✓ Kone on erotettu vedenjakelusta.
- ✓ [Pesuainelokero on poistettu.→ 156](#)

4.3.1 Pesuainelokeron kahvan poistaminen

1. Vapauta lukitusosat.

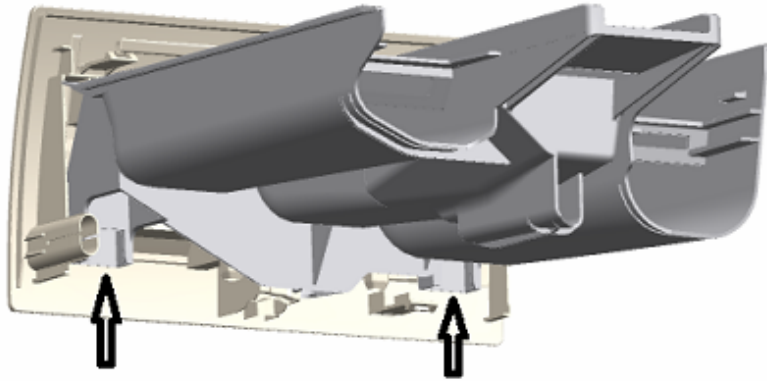

2. Poista pesuainelokeron kahva.

4.3.2 Pesuainelokeron kahvan asentaminen

- ▶ Asenna vastakkaisessa järjestyksessä.

4.4 Luukun vaihtaminen

| | |
|--|---|
|  | ⚠ HUOMAA Avoim saranan alue! Sormien murskautuminen / jääminen väliin <ul style="list-style-type: none">▶ Älä koske saranan alueelle.▶ Käytä suojakäsineitä. |
|--|---|

Vaatus:

- ✔ Kone on erotettu teholahteesta.
- ✔ Kone on erotettu vedenjakelusta.
- ✔ Luukku on avattu.
- ✔ Kaluste-etusivu on poistettu.

4.4.1 Luukun poistaminen

1.

| | |
|---|--|
|  | HUOMIO! Ruuvien avaamisesta aiheutuva osien putoamisen riski! Vauriot koneen muille osille tai asiakkaan kodille, esim. lattia. <ul style="list-style-type: none">▶ Estä komponentin putoaminen. |
|---|--|

| | |
|---|---|
|  | ⚠ HUOMAA Ruuvien avaamisesta aiheutuva osien putoamisen riski! Loukkaantuminen putoavien osien vuoksi. <ul style="list-style-type: none">▶ Estä komponentin putoaminen. |
|---|---|

Poista ruuvit (1).

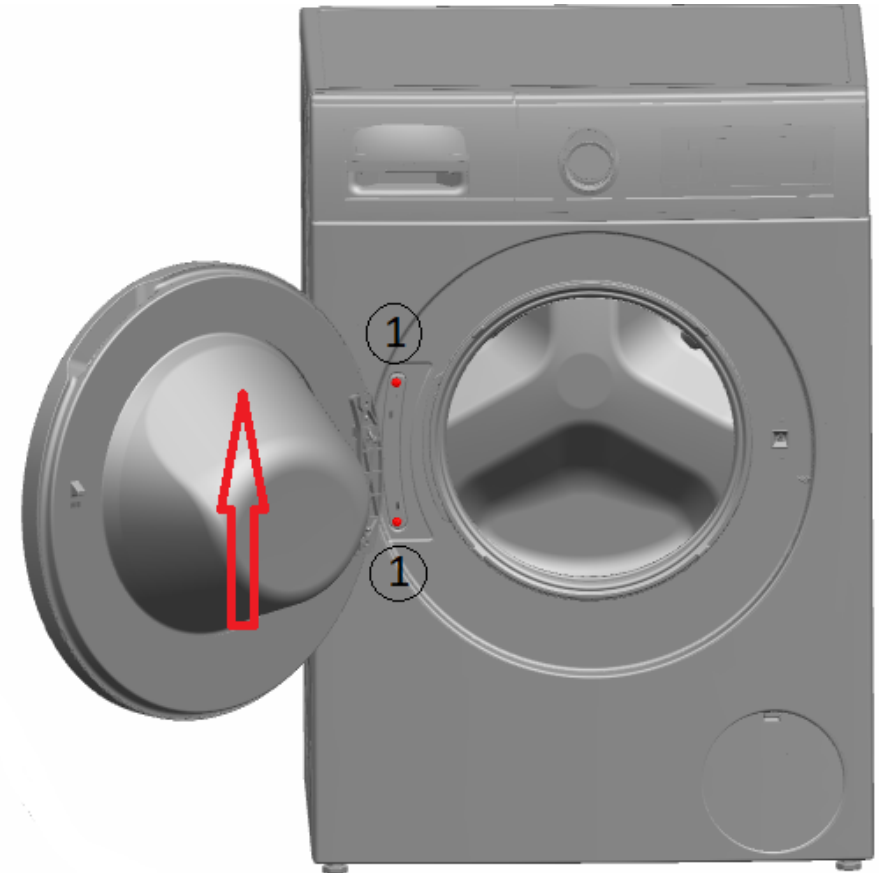

2. Poista luukku yläsuuntaan.

4.4.2 Luukun asennus

- ▶ Asenna vastakkaisessa järjestyksessä.

4.5 Luukun komponenttien vaihtaminen

| | |
|--|---|
|  | <p>⚠ HUOMAA</p> <p>Avoin saranan alue! Sormien murskautuminen / jääminen väliin</p> <ul style="list-style-type: none">▶ Älä koske saranan alueelle.▶ Käytä suojakäsineitä. |
|--|---|

Vaatus:

- ✔ Kone on erotettu tehollisesta.
- ✔ Kone on erotettu vedenjakelusta.
- ✔ Kaluste-etusivu on poistettu.
- ✔ [Luukku on poistettu.→ 158](#)

4.5.1 Luukun komponenttien poistaminen

- ▶ Pura luukku osiin ulkoa sisäänpäin.

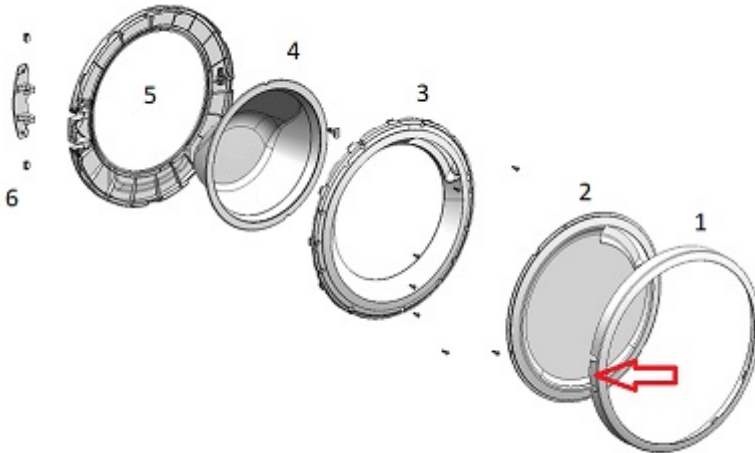

4.5.2 Luukun komponenttien asennus

- ▶ Asenna vastakkaisessa järjestyksessä.

4.6 Luukun saranan vaihtaminen



HUOMAA

Avoim saranan alue!

Sormien murskautuminen / jääminen väliin

- ▶ Älä koske saranan alueelle.
- ▶ Käytä suojakäsineitä.

Vaatus:

- ✔ Kone on erotettu tehollähteestä.
- ✔ Kone on erotettu vedenjakelusta.

4.6.1 Luukun saranan poistaminen

1. Avaa kaksi ruuvia.
2. Poista luukku.
3. Pura luukku osiin ulkoa sisäänpäin.

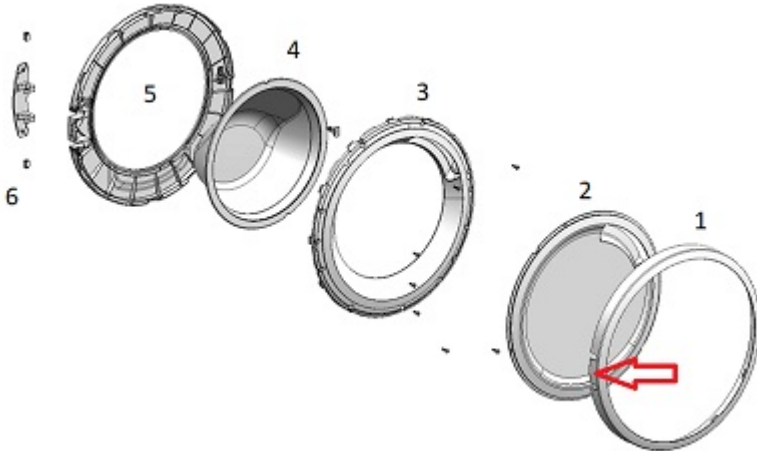



4. Poista luukun sarana.

4.6.2 Luukun saranan asennus

- ▶ Asenna vastakkaisessa järjestyksessä.

4.7 Luukun tiivisteiden vaihtaminen

| | |
|--|--|
|  | ⚠ HUOMAA Terävät kotelon reunat! Viiltovammat ▶ Käytä suojakäsineitä. |
|--|--|

| | |
|--|--|
|  | ⚠ HUOMAA Ruuvien avaamisesta aiheutuva osien putoamisen riski! Loukkaantuminen putoavien osien vuoksi. ▶ Estä komponentin putoaminen. |
|--|--|

| | |
|--|---|
|  | ⚠ HUOMIO! Ruuvien avaamisesta aiheutuva osien putoamisen riski! Vauriot koneen muille osille tai asiakkaan kodille, esim. lattia. ▶ Estä komponentin putoaminen. |
|--|---|

Vaatus:

- ✔ Kone on erotettu teholähteestä.
- ✔ Kone on erotettu vedenjakelusta.
- ✔ Koneeseen on vapaa pääsy.
- ✔ [Pesuainelokero on poistettu.→156](#)
- ✔ Ohjauspaneeli on poistettu.
- ✔ [Luukku on poistettu.→158](#)
- ✔ [Alasuojus on poistettu.→166](#)

4.7.1 Luukun tiivisteiden poistaminen

1. Löysää kiinnitintä rummun lampun päällä.

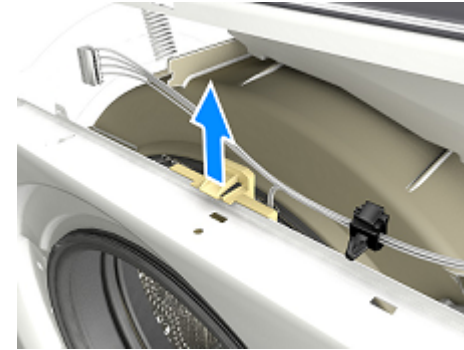

2.

| | |
|---|--|
|  | ⚠ HUOMIO! Pinnan vaurioitumisen riski! Koneen pinta voi naarmuuntua, jos käytetään väärä työkaluja. ▶ Käytä kiristysrenkaan vaihtamiseen vain muovisia työkaluja. |
|---|--|

Poista kiristysrenkas tiivisteestä muovisella työkalulla.

3. Irrota luukun tiiviste etupaneelistä.
4. Irrota kaapeliliitin luukun lukitsimesta.

5. Avaa ruuvit osoitetussa järjestyksessä.



6. Poista etupaneeli.

7. Irrota kaikki letkuliitännät.

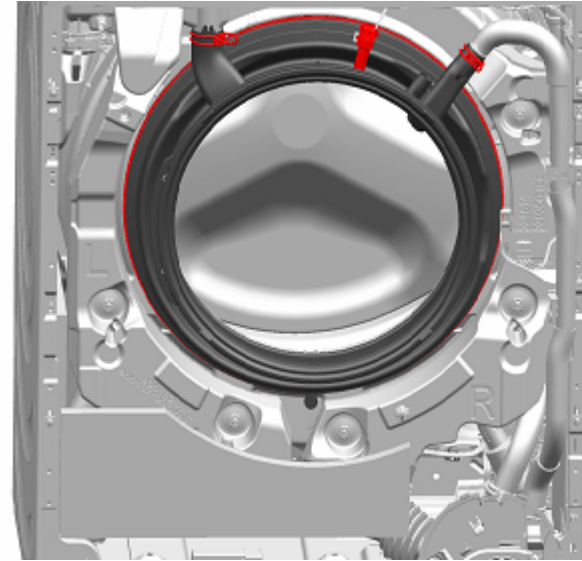

8. Poista luukun tiiviste.

4.7.2 Luukun tiivisteiden asennus

- ▶ Asenna vastakkaisessa järjestyksessä.

4.8 Luukun lukitsimen vaihtaminen

Valmistajana olemme velvoitettuja toimittamaan kuluttajille varaosana ovilukon sekä korjausohjeet (EU) 2019/2023 -säädöksen mukaisesti. Haluaisimme kuitenkin huomauttaa, että ovilukon vaihtamisen jälkeen pätevän sähköasentajan on testattava sähkötekninen turvallisuus ennen kuin laite otetaan uudelleen käyttöön. Tällä henkilöllä on oltava todistettavissa oleva pätevyys maan erityisten lakien, säädösten ja standardien mukaisesti.

| | |
|--|--|
|  | VAARA |
| | <p>Jännitteisten osien aiheuttama sähköiskun vaara! Sähköiskusta aiheutuva hengenvaara väärän korjauksen tapauksessa</p> <ul style="list-style-type: none"> ▶ Sähköosien korjaus tulisi antaa pätevien sähköasentajien suoritettavaksi. ▶ Pyydä korjauksen jälkeen suorittamaan VDE 0701 -säädöksen tai maakontaisten säädösten mukainen turvallisuustesti. |

| | |
|--|--|
|  | HUOMAA |
| | <p>Terävät kotelon reunat! Viiltovammat</p> <ul style="list-style-type: none"> ▶ Käytä suojakäsineitä. |

| | |
|--|--|
|  | VAROITUS |
| | <p>Kallistetun koneen luiskahtaminen! Luunmurtumat/murskavammat</p> <ul style="list-style-type: none"> ▶ Estä koneiden luiskahtaminen. |

| | |
|--|--|
|  | HUOMAA |
| | <p>Ruuvien avaamisesta aiheutuva osien putoamisen riski! Loukkaantuminen putoavien osien vuoksi.</p> <ul style="list-style-type: none"> ▶ Estä komponentin putoaminen. |

| | |
|--|--|
|  | HUOMIO! |
| | <p>Ruuvien avaamisesta aiheutuva osien putoamisen riski! Vauriot koneen muille osille tai asiakkaan kodille, esim. lattia.</p> <ul style="list-style-type: none"> ▶ Estä komponentin putoaminen. |

Vaatimus:

- ✓ Kone on erotettu tehollisesta.
- ✓ Kone on erotettu vedenjakelusta.

- ✓ Koneeseen on vapaa pääsy.
- ✓ Kaluste-etusivu on poistettu.
- ✓ Ohjauspaneeli on poistettu.
- ✓ [Luukku on poistettu. → 158](#)
- ✓ Kiristysrenkas on poistettu.
- ✓ Etupaneeli on poistettu.
- ✓ Luukun tiiviste on poistettu.

4.8.1 Luukun lukitsimen poistaminen

1. Irrota luukun lukitsimen pistotulppa.
2. Vapauta luukun lukitsin.



3. Poista luukun lukitsin.

4.8.2 Luukun lukitsimen asennus

Luukun lukitsimen on oltava oikeassa asennossa, jotta koneen luukun hätäavaustoiminto on mahdollinen.

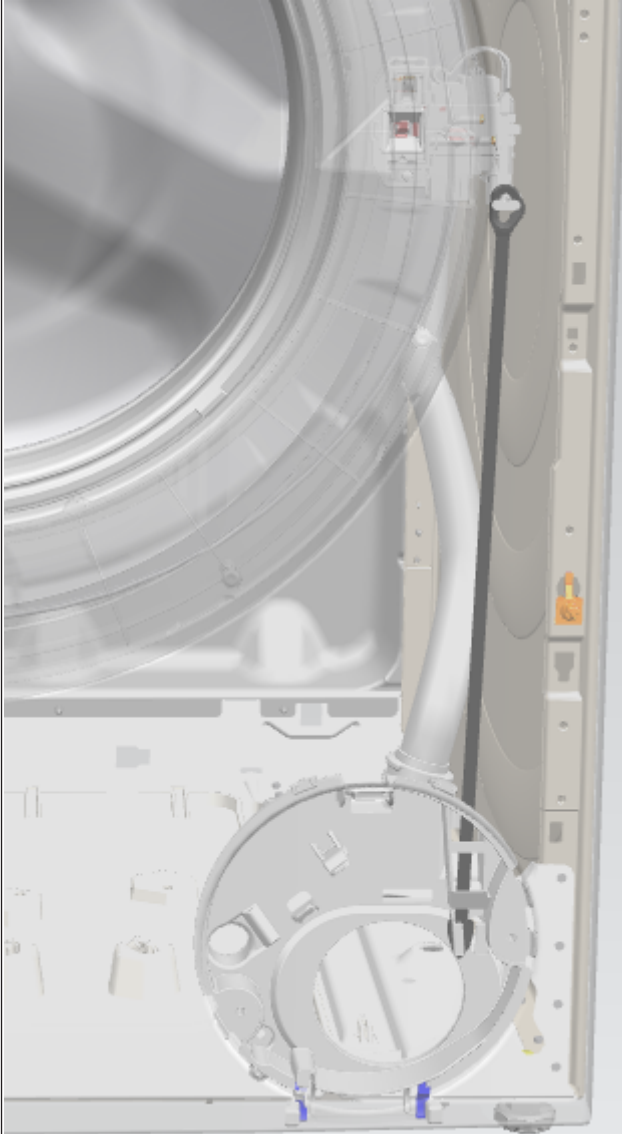

- ▶ Asenna vastakkaisessa järjestyksessä.

4.9 Rummun lampun vaihtaminen



⚠ HUOMAA

Terävät kotelon reunat!
Viiltovammat
▶ Käytä suojakäsineitä.



⚠ VAROITUS

Kallistetun koneen luiskahtaminen.!
Luunmurtumat/murskavammat
▶ Estä koneiden luiskahtaminen.



⚠ HUOMAA

Ruuvien avaamisesta aiheutuva osien putoamisen riski!
Loukkaantuminen putoavien osien vuoksi.
▶ Estä komponentin putoaminen.



⚠ HUOMIO!

Ruuvien avaamisesta aiheutuva osien putoamisen riski!
Vauriot koneen muille osille tai asiakkaan kodille, esim. lattia.
▶ Estä komponentin putoaminen.

Vaatimus:

- ✔ Kone on erotettu teholähteestä.
- ✔ Kone on erotettu vedenjakelusta.
- ✔ Koneeseen on vapaa pääsy.
- ✔ [Pesuainelokero on poistettu.→156](#)
- ✔ Ohjauspaneeli on poistettu.

4.9.1 Rummun lampun poistaminen

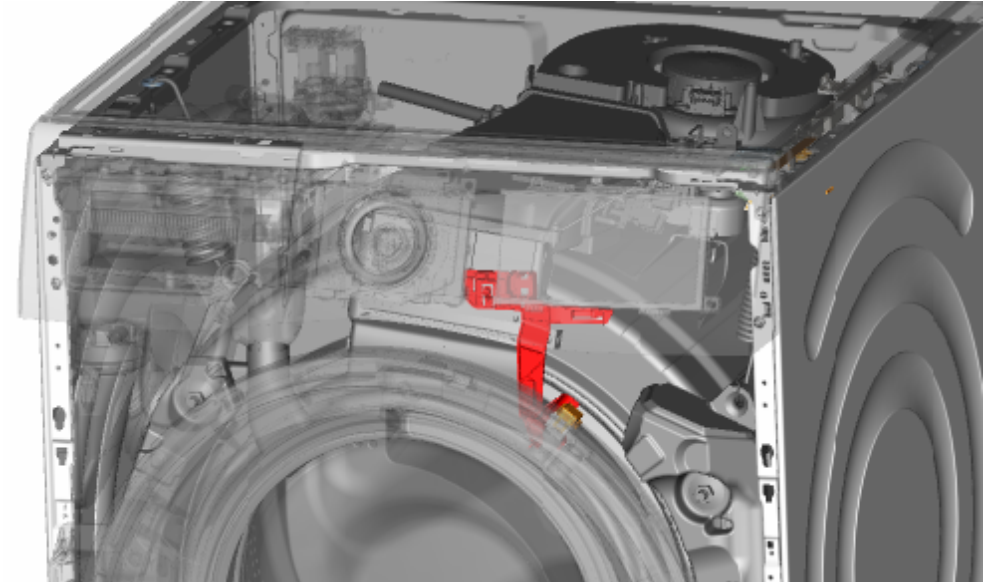

1. Vedä rummun lamppupidike ulos koneesta.
2. Irrota sähköliitännät.
3. Poista lamppu rummun lampunpidikkeestä.

4.9.2 Rummun lampun asennus

- ▶ Asenna vastakkaisessa järjestyksessä.

4.10 Alaosan suojuksen vaihtaminen



Kuva 1: Alaosan ryhmän suojus

Vaatus:

- ✓ Kone on erotettu teholahteesta.
- ✓ Kone on erotettu vedenjakelusta.
- ✓ Kaluste-etusivu on poistettu.

4.10.1 Alaosan suojuksen poistaminen

Vaatus:

- ✓ Kone on erotettu teholahteesta.
- ✓ Kone on erotettu vedenjakelusta.

1. Poista alaosan suojus.

2. Irrota letku pidikkeestä.

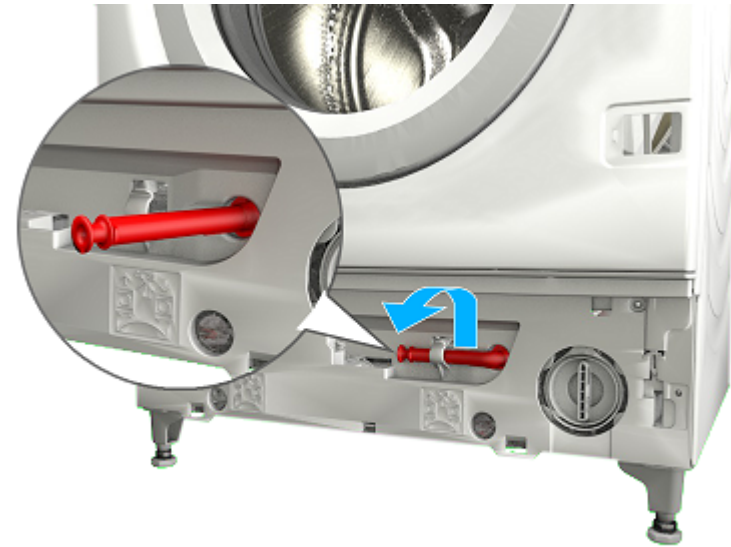

3. 1. Kierrä ruuvi irti (1).
2. Paina kiinnityskohtaa ja poista alasuuntaan (2).

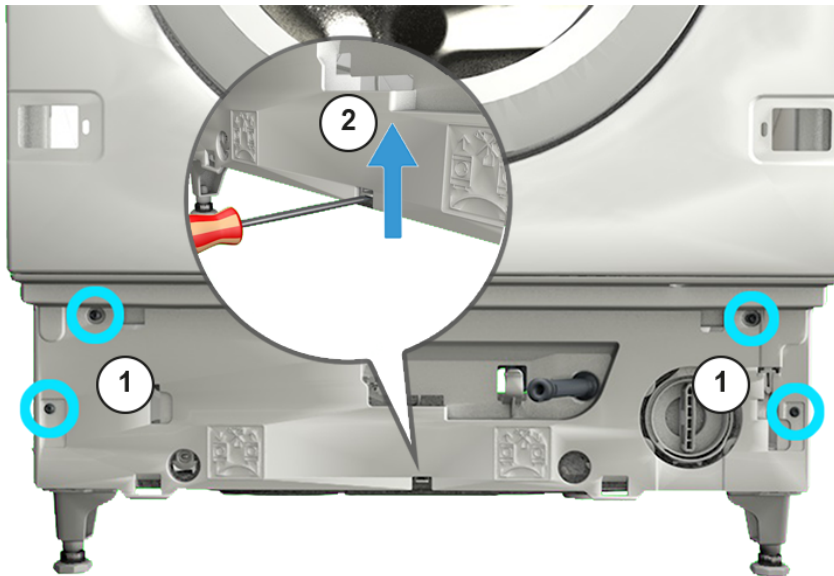

4. Vedä alaosan ryhmän suojusta ja poista etusuuntaan.

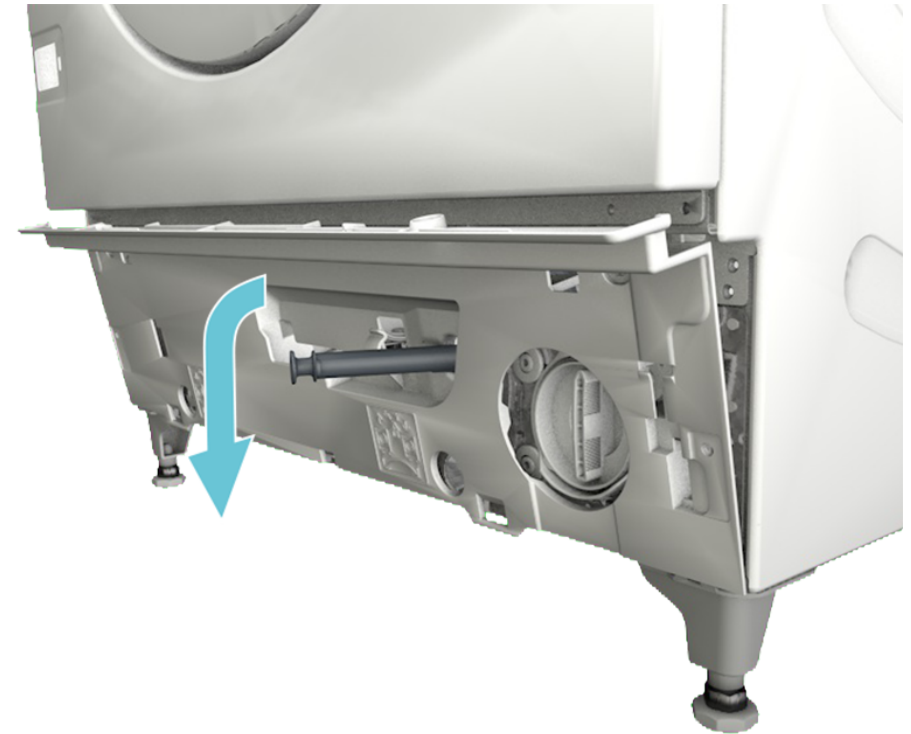

5. Vedä letku ulos suojuksesta.

4.10.2 Suojuksen asennus

- ▶ Asenna vastakkaisessa järjestyksessä.

4.11 Etupaneelin vaihtaminen



⚠ HUOMAA

Terävät kotelon reunat!
Viiltovammat
▶ Käytä suojakäsineitä.

Vaatus:

- ✓ Kone on erotettu teholahteesta.
- ✓ Kone on erotettu vedenjakelusta.
- ✓ Koneeseen on vapaa pääsy.
- ✓ [Pesuainelokero on poistettu.→156](#)
- ✓ Kaluste-etusivu on poistettu.
- ✓ [Luukku on poistettu.→158](#)
- ✓ Luukun tiiviste on poistettu.

4.11.1 Etupaneelin poistaminen

1. Löysää kiinnitintä rummun lampun päällä.

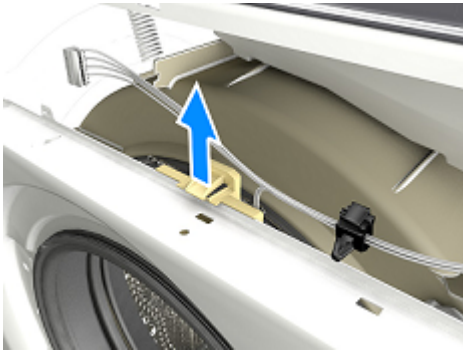

- 2.



⚠ HUOMAA

Ruuvien avaamisesta aiheutuva osien putoamisen riski!
Loukkaantuminen putoavien osien vuoksi.
▶ Estä komponentin putoaminen.



HUOMIO!

Ruuvien avaamisesta aiheutuva osien putoamisen riski!
Vauriot koneen muille osille tai asiakkaan kodille, esim. lattia.
▶ Estä komponentin putoaminen.

Avaa ruuvit osoitetussa järjestyksessä.







3. Poista etupaneeli.

4.11.2 Etupaneelin asentaminen

- ▶ Asenna vastakkaisessa järjestyksessä.

Conseils de réparation - Lave-linge

| | |
|---|------------|
|  A propos de ce document | 171 |
| 1.1 Informations importantes..... | 171 |
| 1.1.1 Objectif..... | 171 |
| 1.2 Explication des symboles..... | 171 |
| 1.2.1 Niveaux de risque..... | 171 |
| 1.2.2 Symboles de danger..... | 171 |
| 1.2.3 Structure des indications d'avertissement..... | 172 |
| 1.2.4 Symboles généraux..... | 172 |
|  Sécurité | 173 |
| 2.1 Consignes de sécurité générales..... | 173 |
| 2.1.1 Tous les appareils électroménagers..... | 173 |
|  Outils et aides | 174 |
|  Réparation | 175 |
| 4.1 Changer le panneau de commande..... | 175 |
| 4.1.1 Retirer le panneau de commande..... | 175 |
| 4.1.2 Monter le panneau de commande..... | 176 |
| 4.2 Changer le bac à produits..... | 177 |
| 4.2.1 Retirer le bac à produits..... | 177 |
| 4.2.2 Monter le bac à produits..... | 177 |
| 4.3 Changer la poignée du bac à produits..... | 178 |
| 4.3.1 Retirer la poignée du bac à produits..... | 178 |
| 4.3.2 Monter la poignée du bac à produits..... | 178 |
| 4.4 Changer la porte..... | 179 |
| 4.4.1 Retirer la porte..... | 179 |
| 4.4.2 Monter la porte..... | 179 |
| 4.5 Changer les composants de la porte..... | 180 |
| 4.5.1 Retirer les composants de la porte..... | 180 |
| 4.5.2 Monter les composants de la porte..... | 180 |
| 4.6 Changer la charnière de porte..... | 181 |
| 4.6.1 Retirer la charnière de porte..... | 181 |
| 4.6.2 Monter la charnière de porte..... | 181 |
| 4.7 Changer le joint de porte..... | 182 |
| 4.7.1 Retirer le joint de porte..... | 182 |
| 4.7.2 Monter le joint de porte..... | 183 |

| | |
|---|-----|
| 4.8 Echange de la fermeture de porte..... | 184 |
| 4.8.1 Retrait de la fermeture de porte..... | 184 |
| 4.8.2 Monter la fermeture de porte..... | 185 |
| 4.9 Changer la lumière du tambour..... | 186 |
| 4.9.1 Retirer la lumière du tambour..... | 186 |
| 4.9.2 Monter la lumière du tambour..... | 186 |
| 4.10 Changer le couvercle inférieur..... | 187 |
| 4.10.1 Retirer le couvercle inférieur..... | 187 |
| 4.10.2 Monter le couvercle..... | 188 |
| 4.11 Changer le panneau de façade..... | 189 |
| 4.11.1 Retirer le panneau de façade..... | 189 |
| 4.11.2 Monter le panneau de façade..... | 190 |

i A propos de ce document

1.1 Informations importantes

1.1.1 Objectif

Les conseils de réparation qui suivent aident le consommateur à réparer l'appareil par lui-même, conformément au règlement sur l'écoconception (en vigueur en 03/2021).

Ils contiennent des informations sur l'échange de certaines pièces détachées, ainsi que des avertissements et risques.

Pour toute question, veuillez contacter notre service après-vente. Nous ne serons responsables des dommages que si les indications de réparation ont été suivies correctement.

1.2 Explication des symboles

1.2.1 Niveaux de risque

Les niveaux de risque se composent d'un symbole et d'un terme d'avertissement. Le mot d'avertissement caractérise la gravité du danger.







| Niveau de dangerosité | Signification |
|--|---|
|  DANGER | Le non respect de la consigne d'avertissement provoque la mort ou des blessures graves. |
|  AVERTISSEMENT | Le non respect de la consigne d'avertissement peut provoquer la mort ou des blessures graves. |
|  PRUDENCE | Le non respect de la consigne d'avertissement peut provoquer des blessures légères. |
| ATTENTION ! | Le non respect de la consigne d'avertissement peut provoquer des dégâts matériels. |

Tableau 1: Niveaux de risque

1.2.2 Symboles de danger

Les symboles de danger sont des représentations figuratives renseignant sur la nature du danger.

Ce document utilise les symboles de danger suivants:

| Symbole de danger | Signification |
|---|---|
|  | Consigne d'avertissement générale |
|  | Danger engendré par la tension électrique |
|  | Risque d'explosion |
|  | Risque de blessures par coupure |

i A propos de ce document





| Symbole de danger | Signification |
|--|--|
|  | Risque de blessures par écrasement |
|  | Danger engendré par des surfaces très chaudes |
|  | Danger engendré par un champ magnétique puissant |
|  | Danger engendré par un rayonnement non ionisant |

Tableau 2: Symboles de danger

1.2.3 Structure des indications d'avertissement

Les consignes d'avertissement figurant dans ce document ont un aspect uniforme et une structure uniforme.

| | |
|--|---|
|  | <p>⚠ DANGER</p> <p>Type et source du danger ! Conséquences possibles en cas de non-respect du danger / de l'avertissement.</p> <ul style="list-style-type: none"> ▶ Mesures et interdictions pour éviter le danger. |
|--|---|

L'exemple suivant montre une consigne d'avertissement mettant en garde contre le risque d'électrocution. La mesure permettant d'éviter le danger est nommée.

| | |
|--|---|
|  | <p>⚠ DANGER</p> <p>Risque d'électrocution par des pièces conductrices de tension ! Mort par électrocution.</p> <ul style="list-style-type: none"> ▶ Débrancher l'appareil du secteur minimum 60 secondes avant de démarrer la réparation. |
|--|---|

1.2.4 Symboles généraux

Ce document utilise les symboles généraux suivants:











| Symbole général | Signification |
|---|---|
|  | Caractérisation d'une astuce particulière (texte et/ou graphique) |
|  | Caractérisation d'une astuce simple (texte seul) |
|  | Caractérisation d'un lien vers une vidéo |
|  | Caractérisation d'outils nécessaires |
|  | Caractérisation de conditions nécessaires |
|  | Caractérisation d'une condition (si... , alors ...) |
|  | Caractérisation d'un résultat |
|  | Caractérisation d'une touche ou surface de commande |
|  | Caractérisation d'une référence de pièce |
|  | Caractérisation d'un texte affiché / fenêtre (sur l'afficheur) |

Tableau 3: Symboles généraux

2.1 Consignes de sécurité générales

2.1.1 Tous les appareils électroménagers

Risque d'électrocution en raison de pièces sous tension!

- Des erreurs lors de réparations impliquant des composants électriques peuvent entraîner une décharge électrique!
- Débrancher l'appareil du secteur minimum 60 secondes avant de démarrer la réparation.
- Après la réparation, effectuer un test de sécurité selon VDE 0701 ou les réglementations spécifiques nationales.

Risque de blessures par coupure sur des bords tranchants!

- Porter des gants de protection.

Risque de casse durant la réparation, maintenance, dépannage et SAV en raison de composants lourds et mobiles

- Porter des chaussures de protection.
- Sécuriser les composants lourds contre le risque de chute.
- Ne pas coller les pièces du châssis sur les composants mobiles.







Risque lié à la sécurité / fonction de l'appareil!





- Utiliser uniquement des pièces détachées d'origine.

Risque d'endommagement des composants sensibles aux décharges électrostatiques!

- Ne pas toucher les modules, ni leur connexions et pistes conductrices.

Outils et aides

| Désignation | Détails | Images |
|---|--|--|
| Outil auxiliaire [15000155] | Cale de montage pour démonter les pièces en plastique |  |
| Tournevis Torx T20 avec perçage [00340764] | 100 mm , pour les vis avec la tige de sécurité |  |
| Clé dynamométrique [15000441] | Clé dynamométrique 20 - 100 Nm | |
| Tournevis plat [00340854] | Lame 3.5 mm x 0.6 mm x 100 mm, Isolation de protection 1000 V AC |  |
| Tournevis plat [00340855] | Lame 5.5 mm x 1.0 mm x 125 mm, isolation de protection 1000 V AC |  |
| Pince à bec fin, angulaire [00341269] | Longueur 200 mm |  |
| Pince coupante [00342182] | Longueur: 200 mm |  |

| Désignation | Détails | Images |
|----------------------------------|-----------------------------|---|
| Clé mixte [00340811] | Taille de la clé 10°mm, M6 |  |
| Combinaison wrench [00340814] | Taille de la clé 13°mm, M8 |  |
| Clé mixte [00340817] | Taille de la clé 17 mm, M10 |  |
| Clé mixte [15000459] | Taille de la clé 16°mm, M10 |  |

4.1 Changer le panneau de commande



⚠️ PRUDENCE

Bords tranchants du boîtier !
Risque de coupures!
▶ Porter des gants de protection.



⚠️ AVERTISSEMENT

Chute d'appareils inclinés !
Fractures/blessures d'écrasement
▶ Sécuriser les appareils contre le risque de chute.



⚠️ PRUDENCE

Risque de pièces qui chutent en raison de vis trop lâches !
Blessures dues à des pièces qui chutent.
▶ Sécuriser les composants contre le risque de chute.



⚠️ ATTENTION !

Risque de pièces qui chutent en raison de vis trop lâches !
Dommages à d'autres parties de l'appareil ou à la propriété du client, p. ex. au plancher.
▶ Sécuriser les composants contre le risque de chute.

Pré-requis:

- ✓ Appareil n'est pas sous tension.
- ✓ L'appareil n'est pas connecté à une alimentation en eau.
- ✓ L'appareil est librement accessible.
- ✓ [Bac à produits retiré. → 177](#)

4.1.1 Retirer le panneau de commande

1. Retirer l'élément de fixation (1).
2. Retirer le couvercle (2).

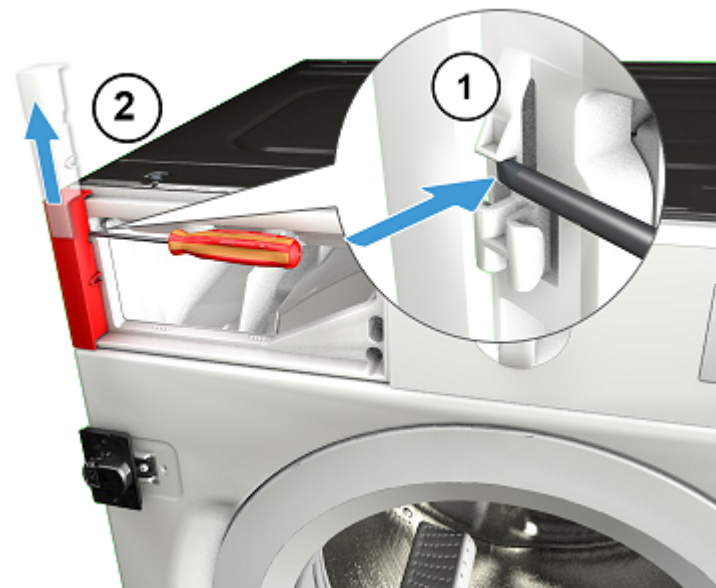

Réparation

2. Retirer les vis.



3. 1. Retirer les éléments de fixation (1, 2).
2. Tirer le panneau de façade vers l'avant (3).

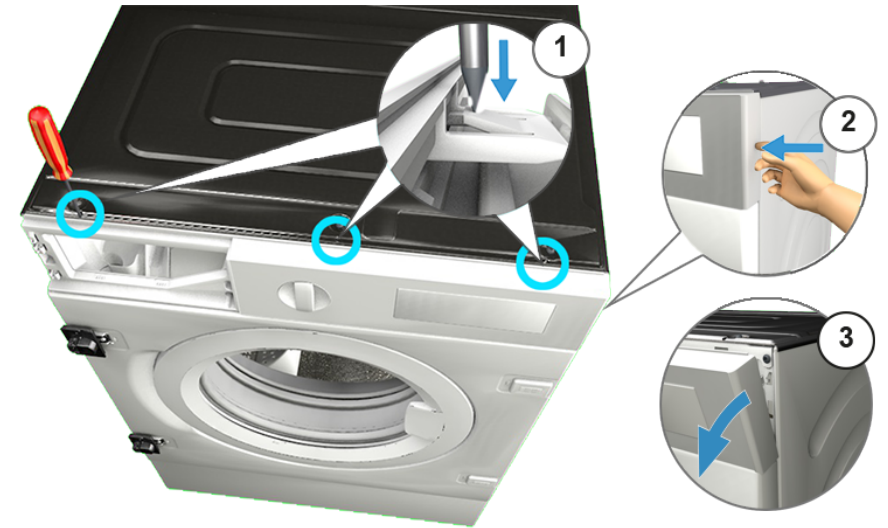

4. Retirer le panneau de commande.

4.1.2 Monter le panneau de commande

- Le montage s'effectue dans l'ordre chronologique inverse.

4.2 Changer le bac à produits

Pré-requis:

- ✓ Appareil n'est pas sous tension.
- ✓ L'appareil n'est pas connecté à une alimentation en eau.

4.2.1 Retirer le bac à produits

1. Ouvrir le bac à produits.
2. 1. Appuyer dessus pour l'insérer (1).
2. Retirer le bac à produits (2).

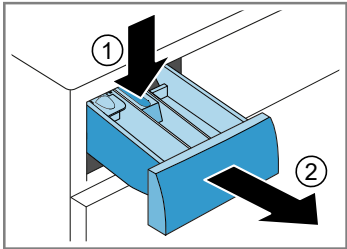

4.2.2 Monter le bac à produits

- ▶ Le montage s'effectue dans l'ordre chronologique inverse.

4.3 Changer la poignée du bac à produits

Pré-requis:

- ✓ Appareil n'est pas sous tension.
- ✓ L'appareil n'est pas connecté à une alimentation en eau.
- ✓ [Bac à produits retiré. →177](#)

4.3.1 Retirer la poignée du bac à produits

1. Retirer les éléments de fixation.

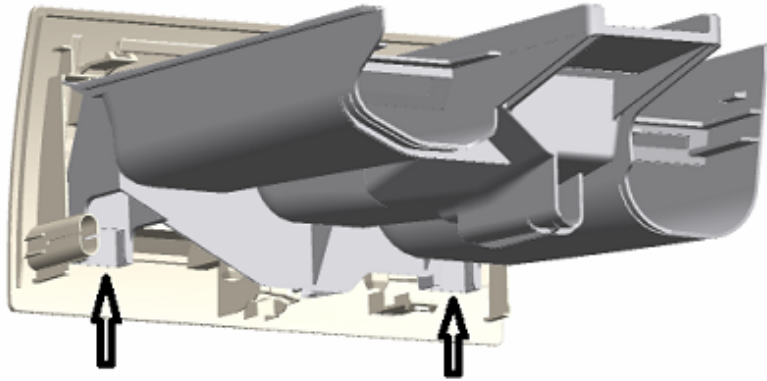

2. Retirer la poignée du bac à produits.

4.3.2 Monter la poignée du bac à produits

- ▶ Le montage s'effectue dans l'ordre chronologique inverse.

4.4 Changer la porte



⚠️ PRUDENCE

Ouvrir la zone de charnière !

Écrasement/coincement des doigts

- ▶ Ne pas insérer les doigts dans la zone de la charnière.
- ▶ Porter des gants de protection.

Pré-requis:

- ✔ Appareil n'est pas sous tension.
- ✔ L'appareil n'est pas connecté à une alimentation en eau.
- ✔ La porte est ouverte.
- ✔ Panneau du meuble a été retiré.

4.4.1 Retirer la porte

1.



ATTENTION !

Risque de pièces qui chutent en raison de vis trop lâches !

Dommmages à d'autres parties de l'appareil ou à la propriété du client, p. ex. au plancher.

- ▶ Sécuriser les composants contre le risque de chute.



⚠️ PRUDENCE

Risque de pièces qui chutent en raison de vis trop lâches !

Blessures dues à des pièces qui chutent.

- ▶ Sécuriser les composants contre le risque de chute.

Retirer les vis (1).

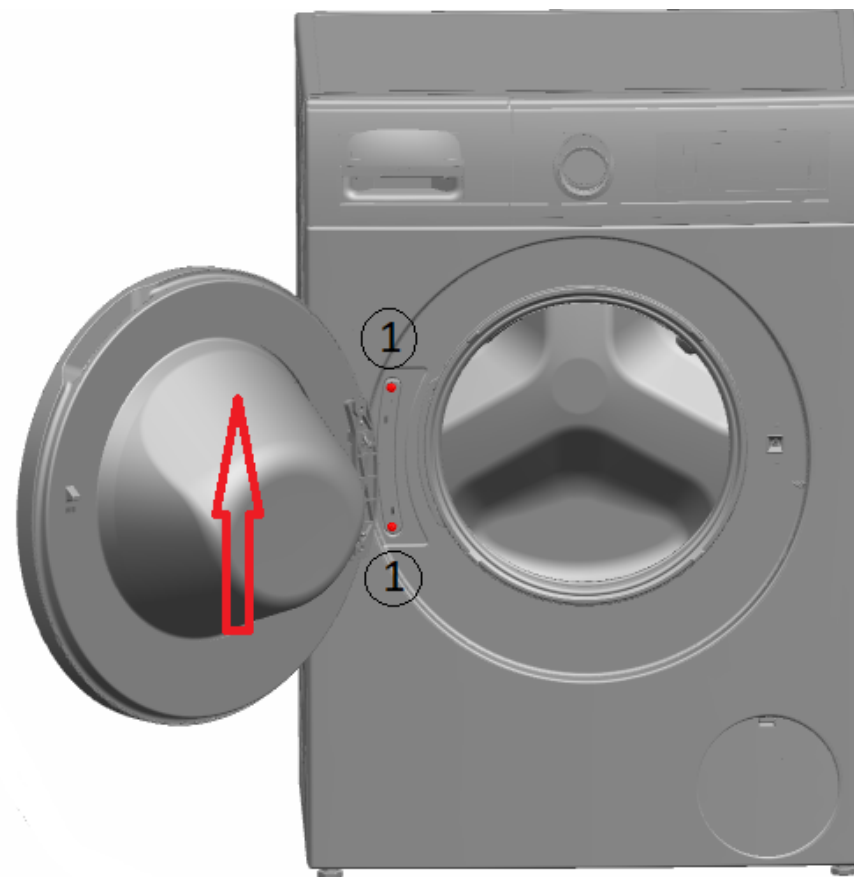

2. Retirer la porte en la soulevant.

4.4.2 Monter la porte

- ▶ Le montage s'effectue dans l'ordre chronologique inverse.

4.5 Changer les composants de la porte



PRUDENCE

Ouvrir la zone de charnière !

Écrasement/coincement des doigts

- ▶ Ne pas insérer les doigts dans la zone de la charnière.
- ▶ Porter des gants de protection.

Pré-requis:

- ✓ Appareil n'est pas sous tension.
- ✓ L'appareil n'est pas connecté à une alimentation en eau.
- ✓ Panneau du meuble a été retiré.
- ✓ [Porte a été retirée.→ 179](#)

4.5.1 Retirer les composants de la porte

- ▶ Démontez la porte de l'extérieur vers l'intérieur.

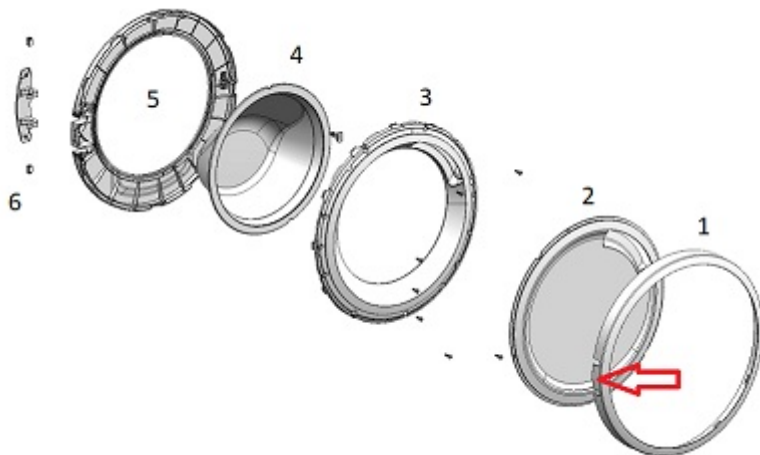

4.5.2 Monter les composants de la porte

- ▶ Le montage s'effectue dans l'ordre chronologique inverse.

4.6 Changer la charnière de porte



PRUDENCE

Ouvrir la zone de charnière !

Écrasement/coincement des doigts

- ▶ Ne pas insérer les doigts dans la zone de la charnière.
- ▶ Porter des gants de protection.

Pré-requis:

- ✔ Appareil n'est pas sous tension.
- ✔ L'appareil n'est pas connecté à une alimentation en eau.

4.6.1 Retirer la charnière de porte

1. Desserrer deux vis.
2. Retirer la porte.
3. Démonter la porte de l'extérieur vers l'intérieur.

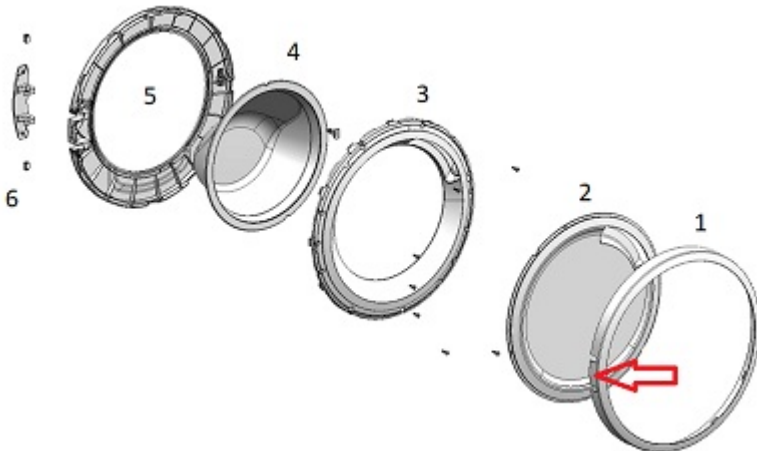

4. Retirer la charnière de la porte.

4.6.2 Monter la charnière de porte

- ▶ Le montage s'effectue dans l'ordre chronologique inverse.

4.7 Changer le joint de porte



PRUDENCE

Bords tranchants du boîtier !
Risque de coupures!
▶ Porter des gants de protection.



PRUDENCE

Risque de pièces qui chutent en raison de vis trop lâches !
Blessures dues à des pièces qui chutent.
▶ Sécuriser les composants contre le risque de chute.



ATTENTION !

Risque de pièces qui chutent en raison de vis trop lâches !
Dommages à d'autres parties de l'appareil ou à la propriété du client, p. ex. au plancher.
▶ Sécuriser les composants contre le risque de chute.

Pré-requis:

- ✓ Appareil n'est pas sous tension.
- ✓ L'appareil n'est pas connecté à une alimentation en eau.
- ✓ L'appareil est librement accessible.
- ✓ [Bac à produits retiré.→177](#)
- ✓ Panneau de commande a été retiré.
- ✓ [Porte a été retirée.→179](#)
- ✓ [Couvercle inférieur a été retiré.→187](#)

4.7.1 Retirer le joint de porte

1. Desserrer le support sur la lumière du tambour.



- 2.



ATTENTION !

Risque de dommage superficiel !
La surface de l'appareil peut être rayée par l'utilisation d'outils inadéquats.
▶ Remplacer le collier de serrage uniquement avec des outils en plastique.

Retirer le collier de serrage de la manchette avec un outil en plastique.

3. Défaire le joint de porte du panneau de façade.
4. Débrancher le connecteur de câble de la fermeture de porte.

5. Desserrer les vis dans l'ordre indiqué.



6. Retirer le panneau de façade.

7. Déconnecter tous les raccords de flexibles.

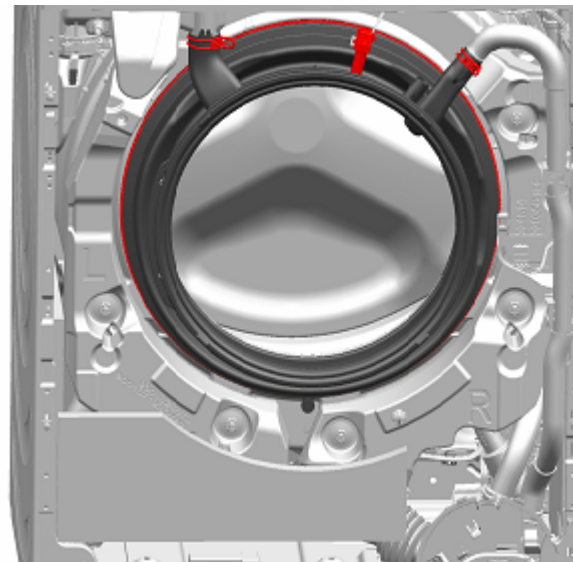

8. Retirer le joint de porte.

4.7.2 Monter le joint de porte

► Le montage s'effectue dans l'ordre chronologique inverse.

4.8 Echange de la fermeture de porte

En tant que fabricant, nous sommes obligés de fournir aux clients la fermeture de porte SAV incluant les instructions de réparation selon la réglementation (EU) 2019/2023. Toutefois, nous aimerions mentionner la nécessité d'effectuer un test électrotechnique par un électricien qualifié, après l'échange d'une fermeture de porte, avant la mise en service de l'appareil. Cette personne doit être qualifiée selon les lois, réglementations et standards nationaux spécifiques, de façon vérifiable.

| | |
|--|---|
|  | ⚠ DANGER |
| | Risque d'électrocution en raison de pièces sous tension ! Risque d'électrocution en cas de réparation non conforme <ul style="list-style-type: none">▶ Les pièces électriques doivent être réparées par des techniciens qualifiés.▶ Après la réparation, effectuer un test de sécurité selon VDE 0701 ou les réglementations spécifiques nationales. |

| | |
|--|---|
|  | ⚠ PRUDENCE |
| | Bords tranchants du boîtier ! Risque de coupures! <ul style="list-style-type: none">▶ Porter des gants de protection. |

| | |
|--|--|
|  | ⚠ AVERTISSEMENT |
| | Chute d'appareils inclinés ! Fractures/blessures d'écrasement <ul style="list-style-type: none">▶ Sécuriser les appareils contre le risque de chute. |

| | |
|--|--|
|  | ⚠ PRUDENCE |
| | Risque de pièces qui chutent en raison de vis trop lâches ! Blessures dues à des pièces qui chutent. <ul style="list-style-type: none">▶ Sécuriser les composants contre le risque de chute. |

| | |
|--|--|
|  | ATTENTION ! |
| | Risque de pièces qui chutent en raison de vis trop lâches ! Dommages à d'autres parties de l'appareil ou à la propriété du client, p. ex. au plancher. <ul style="list-style-type: none">▶ Sécuriser les composants contre le risque de chute. |

Pré-requis:

- ✓ Appareil n'est pas sous tension.

- ✓ L'appareil n'est pas connecté à une alimentation en eau.
- ✓ L'appareil est librement accessible.
- ✓ Panneau du meuble a été retiré.
- ✓ Panneau de commande a été retiré.
- ✓ [Porte a été retirée. → 179](#)
- ✓ Collier de serrage a été retiré.
- ✓ Panneau de façade a été retiré.
- ✓ Joint de porte a été retiré.

4.8.1 Retrait de la fermeture de porte

1. Débrancher la prise de la fermeture de porte.
2. Défaire la fermeture de porte.



3. Retirer la fermeture de porte.

4.8.2 Monter la fermeture de porte

La fermeture de porte doit être dans la bonne position pour garantir la fonction d'ouverture d'urgence de la porte de l'appareil.

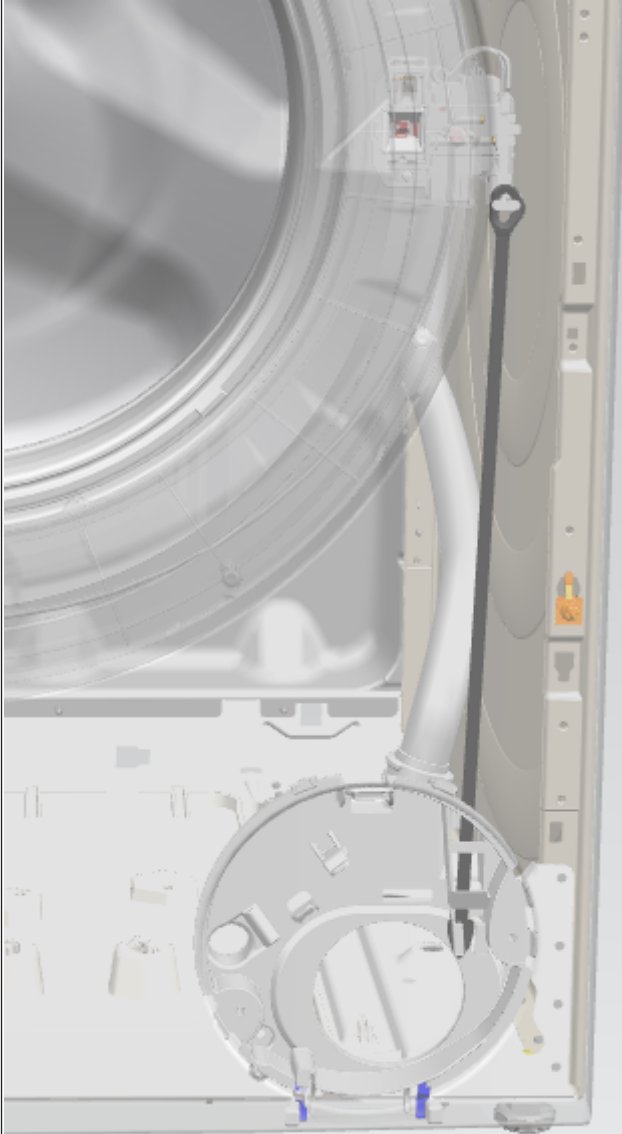

- ▶ Le montage s'effectue dans l'ordre chronologique inverse.

4.9 Changer la lumière du tambour



⚠️ PRUDENCE

Bords tranchants du boîtier !
Risque de coupures!
▶ Porter des gants de protection.



⚠️ AVERTISSEMENT

Chute d'appareils inclinés !
Fractures/blessures d'écrasement
▶ Sécuriser les appareils contre le risque de chute.



⚠️ PRUDENCE

Risque de pièces qui chutent en raison de vis trop lâches !
Blessures dues à des pièces qui chutent.
▶ Sécuriser les composants contre le risque de chute.



⚠️ ATTENTION !

Risque de pièces qui chutent en raison de vis trop lâches !
Dommages à d'autres parties de l'appareil ou à la propriété du client, p. ex. au plancher.
▶ Sécuriser les composants contre le risque de chute.

Pré-requis:

- ✓ Appareil n'est pas sous tension.
- ✓ L'appareil n'est pas connecté à une alimentation en eau.
- ✓ L'appareil est librement accessible.
- ✓ [Bac à produits retiré. → 177](#)
- ✓ Panneau de commande a été retiré.

4.9.1 Retirer la lumière du tambour

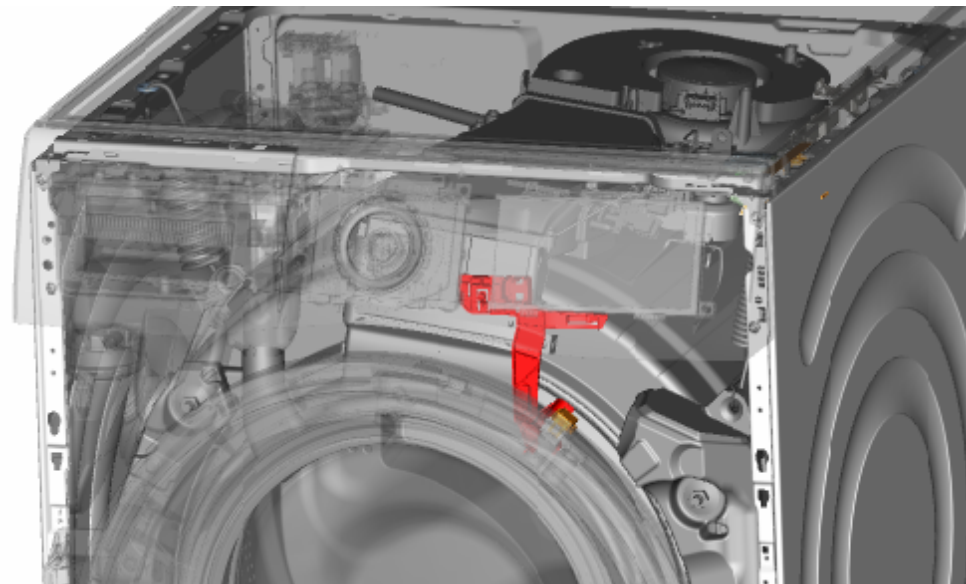

1. Sortir le support de la lumière du tambour de l'appareil.
2. Débrancher les connexions électriques.
3. Retirer la lumière du tambour de son support.

4.9.2 Monter la lumière du tambour

- ▶ Le montage s'effectue dans l'ordre chronologique inverse.

4.10 Changer le couvercle inférieur



Fig. 1: Couvercle du groupe inférieur

Pré-requis:

- ✓ Appareil n'est pas sous tension.
- ✓ L'appareil n'est pas connecté à une alimentation en eau.
- ✓ Panneau du meuble a été retiré.

4.10.1 Retirer le couvercle inférieur

Pré-requis:

- ✓ Appareil n'est pas sous tension.
- ✓ L'appareil n'est pas connecté à une alimentation en eau.

1. Retirer le couvercle inférieur.

2. Détacher le flexible du support.

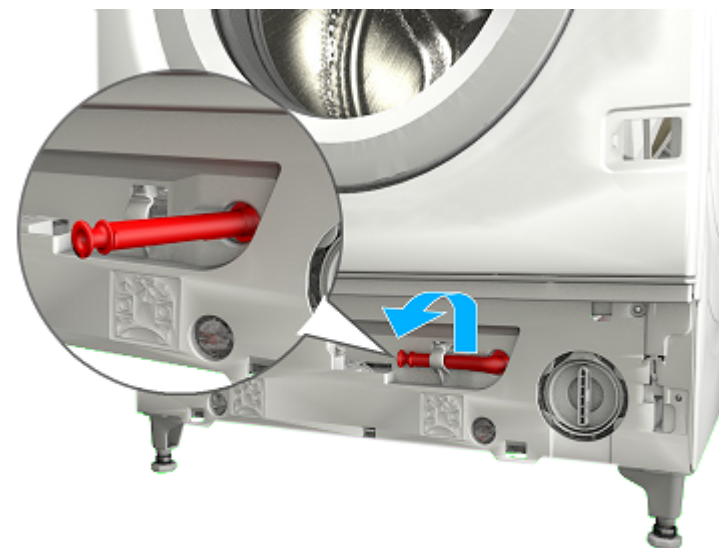

Réparation

3. 1. Dévisser la vis (1).
2. Appuyer sur le point de rétention et le retirer par le bas (2).

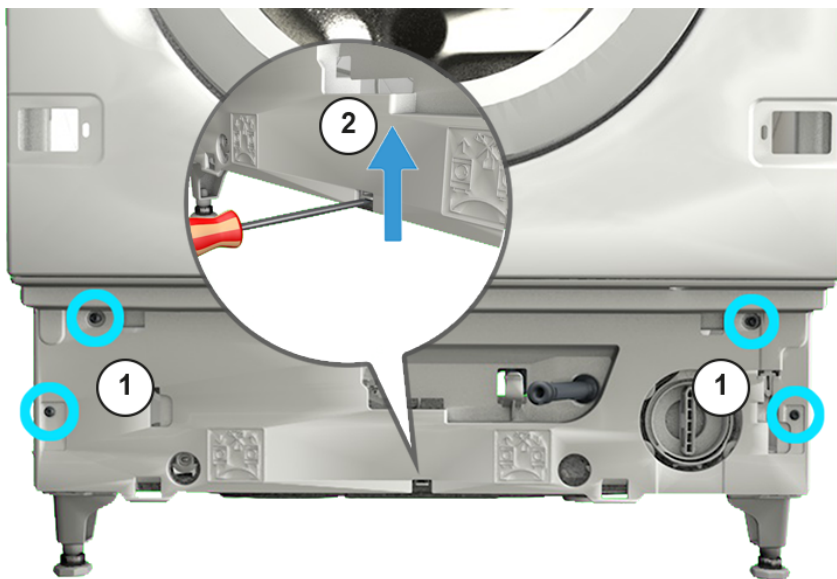

4. Tirer sur le couvercle du groupe inférieur et le retirer vers l'avant.

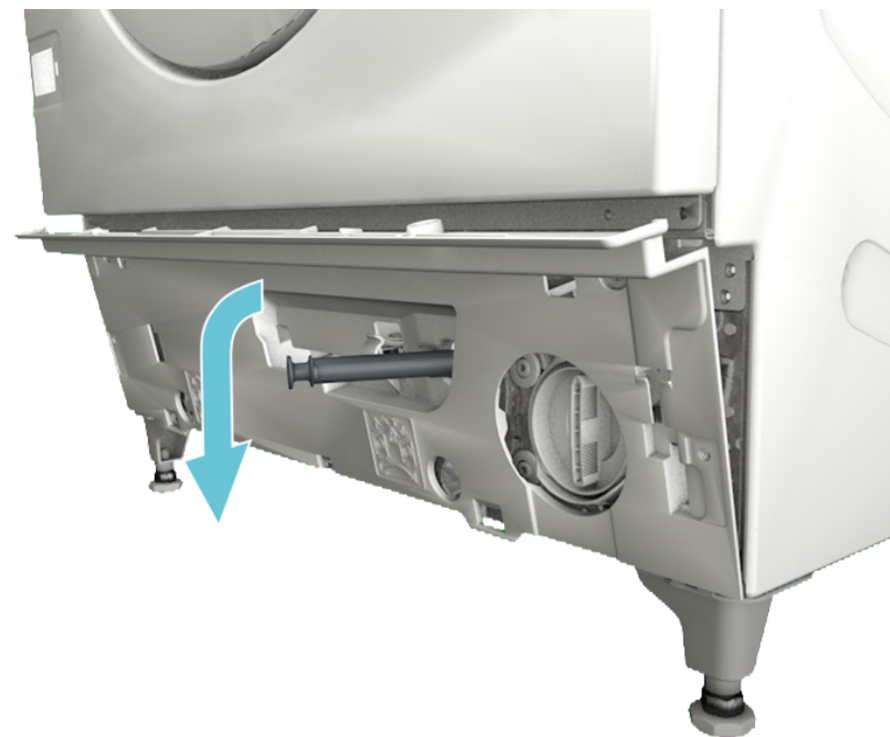

5. Retirer le flexible à travers le couvercle.

4.10.2 Monter le couvercle

- Le montage s'effectue dans l'ordre chronologique inverse.

4.11 Changer le panneau de façade



⚠️ PRUDENCE

Bords tranchants du boîtier !
Risque de coupures!
▶ Porter des gants de protection.

Pré-requis:

- ✓ Appareil n'est pas sous tension.
- ✓ L'appareil n'est pas connecté à une alimentation en eau.
- ✓ L'appareil est librement accessible.
- ✓ [Bac à produits retiré. → 177](#)
- ✓ Panneau du meuble a été retiré.
- ✓ [Porte a été retirée. → 179](#)
- ✓ Joint de porte a été retiré.

4.11.1 Retirer le panneau de façade

1. Desserrer le support sur la lumière du tambour.

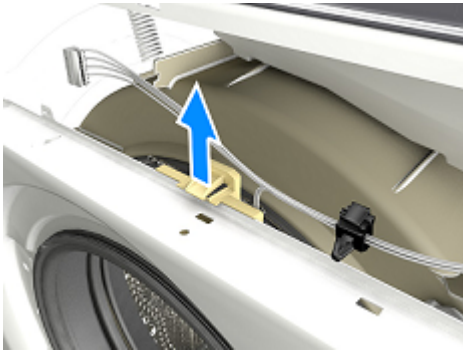

- 2.



⚠️ PRUDENCE

Risque de pièces qui chutent en raison de vis trop lâches !
Blessures dues à des pièces qui chutent.
▶ Sécuriser les composants contre le risque de chute.



ATTENTION !

Risque de pièces qui chutent en raison de vis trop lâches !
Dommages à d'autres parties de l'appareil ou à la propriété du client, p. ex. au plancher.
▶ Sécuriser les composants contre le risque de chute.

Desserrer les vis dans l'ordre indiqué.



3. Retirer le panneau de façade.

4.11.2 Monter le panneau de façade

► Le montage s'effectue dans l'ordre chronologique inverse.

Reparatur Hinweise - Waschmaschine

Zu diesem Dokument..... 192

| | | |
|-------|---------------------------|-----|
| 1.1 | Wichtige Hinweise: | 192 |
| 1.1.1 | Zweck | 192 |
| 1.2 | Zeichenerklärung | 192 |
| 1.2.1 | Gefahrenstufen | 192 |
| 1.2.2 | Gefahrensymbole | 192 |
| 1.2.3 | Struktur der Warnhinweise | 193 |
| 1.2.4 | Allgemeine Symbole | 193 |

Sicherheit..... 194

| | | |
|-------|--------------------------------|-----|
| 2.1 | Allgemeine Sicherheitshinweise | 194 |
| 2.1.1 | Alle Hausgeräte | 194 |

Werkzeuge und Hilfsmittel..... 195

Instandsetzen 196

| | | |
|-------|---|-----|
| 4.1 | Austauschen der Bedienblende | 196 |
| 4.1.1 | Ausbauen der Bedienblende | 196 |
| 4.1.2 | Einbauen der Bedienblende | 197 |
| 4.2 | Austauschen der Waschmittelschublade | 198 |
| 4.2.1 | Ausbauen der Waschmittelschublade | 198 |
| 4.2.2 | Einbauen der Waschmittelschublade | 198 |
| 4.3 | Austauschen des Griffs der Waschmittelschublade | 199 |
| 4.3.1 | Ausbauen des Griffs der Waschmittelschublade | 199 |
| 4.3.2 | Einbauen des Griffs der Waschmittelschublade | 199 |
| 4.4 | Tür austauschen | 200 |
| 4.4.1 | Ausbauen der Tür | 200 |
| 4.4.2 | Einbauen der Tür | 200 |
| 4.5 | Austauschen der Türkomponenten | 201 |
| 4.5.1 | Ausbauen der Türkomponenten | 201 |
| 4.5.2 | Einbauen der Türkomponenten | 201 |
| 4.6 | Türscharnier austauschen | 202 |
| 4.6.1 | Ausbauen des Türscharniers | 202 |
| 4.6.2 | Einbauen des Türscharniers | 202 |
| 4.7 | Austauschen der Türdichtung | 203 |
| 4.7.1 | Ausbauen der Türdichtung | 203 |
| 4.7.2 | Einbauen der Türdichtung | 204 |

| | | |
|--------|------------------------------------|-----|
| 4.8 | Austauschen der Türverriegelung | 205 |
| 4.8.1 | Türverriegelung demontieren | 205 |
| 4.8.2 | Türverriegelung montieren | 206 |
| 4.9 | Austauschen der Trommelbeleuchtung | 207 |
| 4.9.1 | Ausbauen der Trommelbeleuchtung | 207 |
| 4.9.2 | Einbauen der Trommelbeleuchtung | 207 |
| 4.10 | Austauschen der unteren Abdeckung | 208 |
| 4.10.1 | Ausbauen der unteren Abdeckung | 208 |
| 4.10.2 | Abdeckung montieren | 209 |
| 4.11 | Austauschen der Frontblende | 210 |
| 4.11.1 | Ausbauen der Frontblende | 210 |
| 4.11.2 | Einbauen der Frontblende | 211 |

Zu diesem Dokument

1.1 Wichtige Hinweise:

1.1.1 Zweck

Diese Reparaturhinweise dienen zur Unterstützung des Kunden bei der selbständigen Gerätereparatur gemäß der entsprechenden Ökodesign-Richtlinie (ab 03/2021).

Sie enthalten Informationen zum Austausch bestimmter Ersatzteile sowie Warn- und Gefahrenhinweise.

Bitte wenden Sie sich in Zweifelsfällen an unseren Kundendienst. Bei nicht ordnungsgemäßer Befolgung der Reparaturhinweise ist die Schadenshaftung ausgeschlossen.

1.2 Zeichenerklärung

1.2.1 Gefahrenstufen

Die Gefahrenstufen bestehen aus einem Symbol und einem Signalwort. Das Signalwort kennzeichnet die Schwere der Gefahr.









| Gefahrenstufe | Bedeutung |
|---|---|
|  | Nichtbeachtung des Warnhinweises führt zu Tod oder schweren Verletzungen. |
|  | Nichtbeachtung des Warnhinweises kann zu Tod oder schweren Verletzungen führen. |
|  | Nichtbeachtung des Warnhinweises kann zu leichten Verletzungen führen. |
|  | Nichtbeachtung des Warnhinweises kann zu Sachschäden führen. |

Tabelle 1: Gefahrenstufen

1.2.2 Gefahrensymbole

Gefahrensymbole sind sinnbildliche Darstellungen, die einen Hinweis auf die Art der Gefahr geben.

In diesem Dokument werden folgende Gefahrensymbole verwendet:

| Gefahrensymbol | Bedeutung |
|---|-----------------------------------|
|  | Allgemeiner Warnhinweis |
|  | Gefahr durch elektrische Spannung |
|  | Gefahr durch Explosion |
|  | Gefahr von Schnittverletzungen |
|  | Gefahr von Quetschverletzungen |

Zu diesem Dokument





| Gefahrensymbol | Bedeutung |
|--|---|
|  | Gefahr durch heiße Oberflächen |
|  | Gefahr durch starkes Magnetfeld |
|  | Gefahr durch nicht ionisierende Strahlung |

Tabelle 2: Gefahrensymbole

1.2.3 Struktur der Warnhinweise

Warnhinweise haben in diesem Dokument ein einheitliches Aussehen und eine einheitliche Struktur.



| | |
|--|--|
|  |  GEFAHR |
| | <p>Art und Quelle der Gefahr! Mögliche Folgen bei Nichtbeachtung der Gefahr / des Warnhinweises.</p> <ul style="list-style-type: none"> ▶ Maßnahmen und Verbote zur Vermeidung der Gefahr. |

Das folgende Beispiel zeigt einen Warnhinweis, der vor Stromschlaggefahr durch spannungsführende Teile warnt. Die Maßnahme zur Vermeidung der Gefahr wird genannt.

| | |
|--|---|
|  |  GEFAHR |
| | <p>Stromschlaggefahr durch spannungsführende Teile! Tod durch Stromschlag</p> <ul style="list-style-type: none"> ▶ Gerät mindestens 60 Sekunden vor Reparaturbeginn vom Netz trennen. |

1.2.4 Allgemeine Symbole

In diesem Dokument werden folgende allgemeine Symbole verwendet:

| Allg. Symbol | Bedeutung |
|--|---|
|  | Kennzeichnung eines besonderen (Text und/oder Grafik) Tipps |
|  | Kennzeichnung eines einfachen (nur Text) Tipps |

| Allg. Symbol | Bedeutung |
|---|--|
|  | Kennzeichnung eines Links zu einer Videoanleitung |
|  | Kennzeichnung erforderlicher Werkzeuge |
|  | Kennzeichnung erforderlicher Voraussetzungen |
|  | Kennzeichnung einer Bedingung (Wenn ..., dann ...) |
|  | Kennzeichnung eines Ergebnisses |
| [Start] | Kennzeichnung einer Taste oder Schaltfläche |
| [00123456] | Kennzeichnung einer Materialnummer |
| Status | Kennzeichnung eines angezeigten Textes / Fensters (im Gerätedisplay) |

Tabelle 3: Allgemeine Symbole

2.1 Allgemeine Sicherheitshinweise

2.1.1 Alle Hausgeräte

Stromschlaggefahr durch spannungsführende Teile!

- Wenn elektrische Komponenten fehlerhaft repariert werden, besteht Stromschlaggefahr!
- Das Gerät mindestens 60 Sekunden vor Beginn der Arbeiten vom Netz trennen.
- Nach der Reparatur muss eine Sicherheitsprüfung nach VDE 0701 oder länderspezifischen Vorschriften durchgeführt werden.

Verletzungsgefahr durch scharfe Kanten!

- Schutzhandschuhe tragen.

Quetschgefahr während Reparatur-, Wartungs-, Fehlersuche- und Servicearbeiten durch schwere sich bewegende Bauteile

- Schutzhandschuhe tragen.
- Schwere Bauteile gegen Herabfallen sichern.
- Körperteile nicht in sich bewegende Bauteile stecken.







Gefährdung der Gerätesicherheit/-funktion!





- Ausschließlich Originalersatzteile verwenden.

Gefahr der Beschädigung elektrostatisch gefährdeter Bauteile (elektrostatische Entladungen)!





- Die Module, einschließlich ihrer Anschlüsse und Leiterbahnen, keinesfalls berühren.

Werkzeuge und Hilfsmittel

| Bezeichnung | Details | Bilder |
|--|--|--|
| Hilfswerkzeug [15000155] | Montagekeil zum Ausrasten von Plastikteilen |  |
| Schraubendreher Torx T20 mit Boh- rung [00340764] | 100 mm, für Schrauben mit Si- cherheitsstift |  |
| Drehmoment- Schlüssel [15000441] | Drehmoment-Schlüssel 20 - 100 Nm | |
| Schlitzschrauben- dreher [00340854] | Klinge 3,5 mm x 0,6 mm x 100 mm, Schutzisolation 1000 V Wechselstrom |  |
| Schlitzschrauben- dreher [00340855] | Klinge 5,5 mm x 1,0 mm x 125 mm, Schutzisolation 1000 V Wechselstrom |  |
| Spitzzange, gebo- gen [00341269] | Länge 200 mm |  |
| Seitenschneider [00342182] | Länge: 200 mm |  |

| Bezeichnung | Details | Bilder |
|--|---------------------------|---|
| Gabel-Ringschlüs- sel [00340811] | Schlüsselweite 10°mm, M6 |  |
| Combination wrench [00340814] | Schlüsselweite 13°mm, M8 |  |
| Gabel-Ringschlüs- sel [00340817] | Schlüsselweite 17 mm, M10 |  |
| Gabel-Ringschlüs- sel [15000459] | Schlüsselweite 16°mm, M10 |  |

4.1 Austauschen der Bedienblende

| | |
|--|---|
|  | VORSICHT Scharfe Gehäusekanten! Schnittverletzungen ▶ Schutzhandschuhe tragen. |
|  | WARNUNG Wegrutschen des gekippten Gerätes! Knochenbrüche / Quetschungen ▶ Gerät gegen Wegrutschen sichern. |
|  | VORSICHT Risiko herabfallender Teile durch gelöste Schrauben! Verletzungsgefahr durch herabfallende Teile. ▶ Die Komponenten gegen Herunterfallen sichern. |
|  | ACHTUNG Risiko herabfallender Teile durch gelöste Schrauben! Gefahr der Beschädigung anderer Geräteteile bzw. von Beschädigungen im Haushalt des Kunden, z. B. des Bodens. ▶ Die Komponenten gegen Herunterfallen sichern. |

Voraussetzung:

- ✓ Das Gerät ist spannungsfrei.
- ✓ Das Gerät ist von der Wasserversorgung getrennt.
- ✓ Das Gerät ist frei zugänglich.
- ✓ [Die Waschmittelschublade ist entfernt worden. → Seite 198](#)

4.1.1 Ausbauen der Bedienblende

1. Rastelement lösen (1).
2. Die Abdeckung entfernen (2).

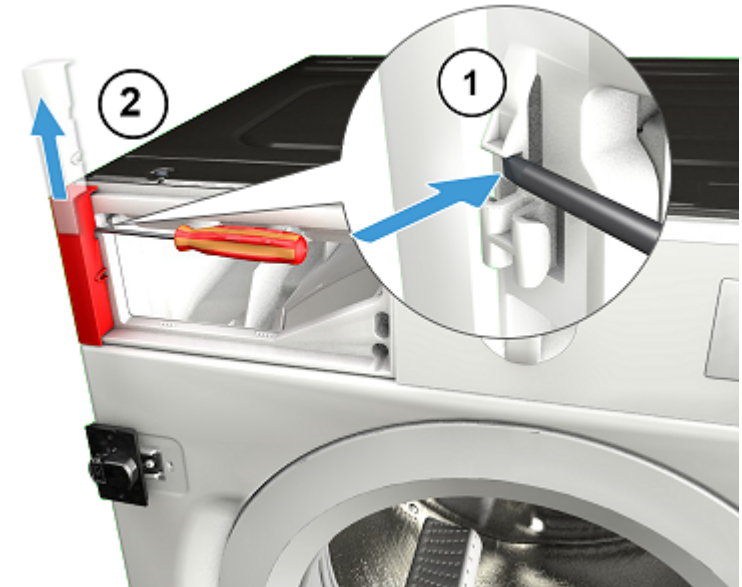

Instandsetzen

2. Die Schrauben entfernen.



3. 1. Die Rastelemente lösen (1, 2).
2. Die Bedienblende nach vorn ziehen (3).

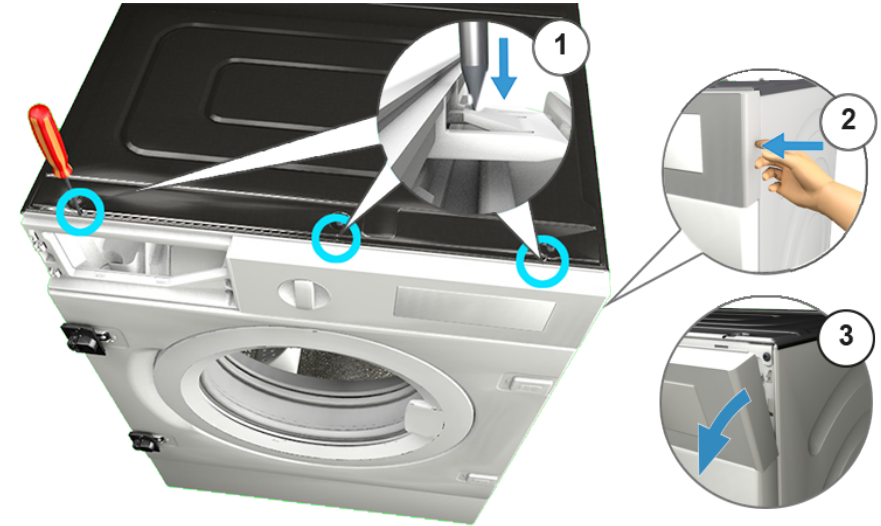

4. Die Bedienblende entfernen.

4.1.2 Einbauen der Bedienblende

- Der Einbau erfolgt in umgekehrter Reihenfolge.

4.2 Austauschen der Waschmittelschublade

Voraussetzung:

- ✔ Das Gerät ist spannungsfrei.
- ✔ Das Gerät ist von der Wasserversorgung getrennt.

4.2.1 Ausbauen der Waschmittelschublade

1. Die Waschmittelschublade herausziehen.
2. 1. Druck auf den Einsatz ausüben (1).
2. Die Waschmittelschublade entfernen (2).

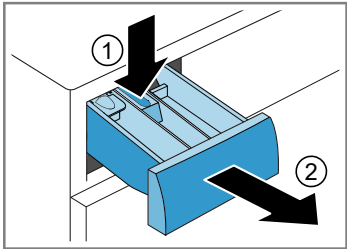

4.2.2 Einbauen der Waschmittelschublade

- ▶ Der Einbau erfolgt in umgekehrter Reihenfolge.

4.3 Austauschen des Griffs der Waschmittelschublade

Voraussetzung:

- ✓ Das Gerät ist spannungsfrei.
- ✓ Das Gerät ist von der Wasserversorgung getrennt.
- ✓ [Die Waschmittelschublade ist entfernt worden.](#) → [Seite 198](#)

4.3.1 Ausbauen des Griffs der Waschmittelschublade

1. Die Rastelemente lösen.

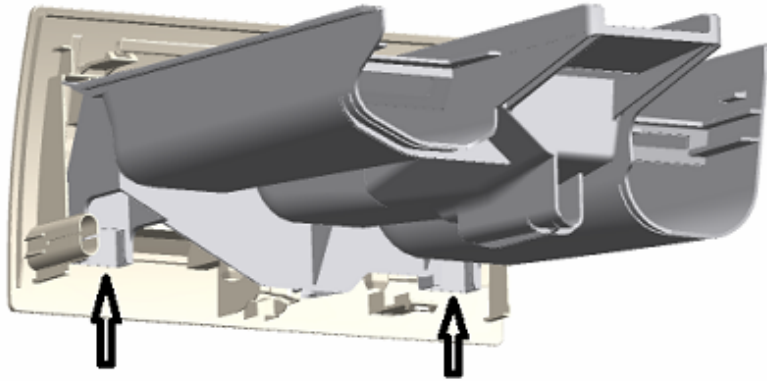

2. Den Griff der Waschmittelschublade entfernen.

4.3.2 Einbauen des Griffs der Waschmittelschublade

- ▶ Der Einbau erfolgt in umgekehrter Reihenfolge.

4.4 Tür austauschen

| | |
|--|--|
|  | ⚠ VORSICHT Offener Scharnierbereich! Quetschen / Einklemmen der Finger ▶ Nicht in den Scharnierbereich greifen. ▶ Schutzhandschuhe tragen. |
|--|--|

Voraussetzung:

- ✔ Das Gerät ist spannungsfrei.
- ✔ Das Gerät ist von der Wasserversorgung getrennt.
- ✔ Tür ist offen.
- ✔ Die Möbelfront ist demontiert worden.

4.4.1 Ausbauen der Tür

1.

| | |
|---|---|
|  | ACHTUNG Risiko herabfallender Teile durch gelöste Schrauben! Gefahr der Beschädigung anderer Geräteteile bzw. von Beschädigungen im Haushalt des Kunden, z. B. des Bodens. ▶ Die Komponenten gegen Herunterfallen sichern. |
|---|---|

| | |
|--|---|
|  | ⚠ VORSICHT Risiko herabfallender Teile durch gelöste Schrauben! Verletzungsgefahr durch herabfallende Teile. ▶ Die Komponenten gegen Herunterfallen sichern. |
|--|---|

Schrauben entfernen (1).

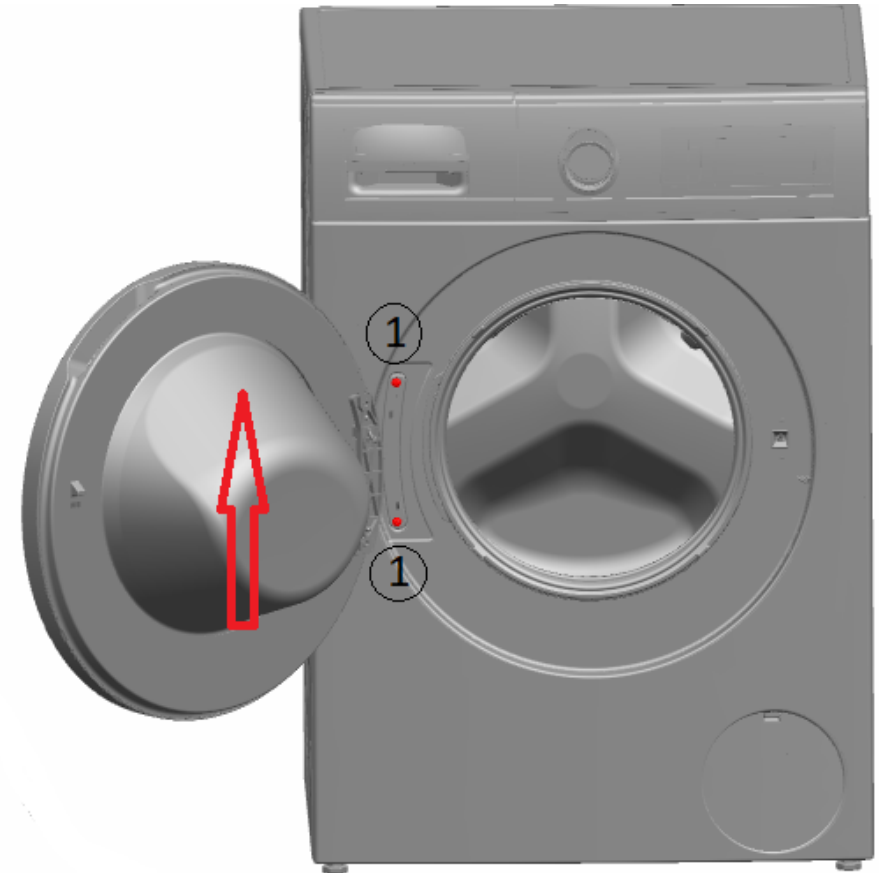

2. Die Tür nach oben entfernen.

4.4.2 Einbauen der Tür

- ▶ Der Einbau erfolgt in umgekehrter Reihenfolge.

4.5 Austauschen der Türkomponenten

| | |
|--|---|
|  | ⚠ VORSICHT |
| | Offener Scharnierbereich! Quetschen / Einklemmen der Finger ▶ Nicht in den Scharnierbereich greifen. ▶ Schutzhandschuhe tragen. |

Voraussetzung:

- ✔ Das Gerät ist spannungsfrei.
- ✔ Das Gerät ist von der Wasserversorgung getrennt.
- ✔ Die Möbelfront ist demontiert worden.
- ✔ Tür ist ausgebaut. → [Seite 200](#)

4.5.1 Ausbauen der Türkomponenten

- ▶ Die Tür von außen nach innen demontieren.

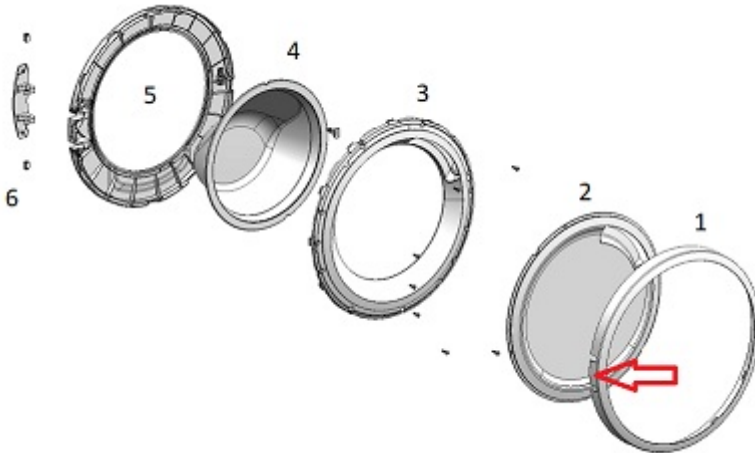

4.5.2 Einbauen der Türkomponenten

- ▶ Der Einbau erfolgt in umgekehrter Reihenfolge.

4.6 Türscharnier austauschen



⚠ VORSICHT

Offener Scharnierbereich!

Quetschen / Einklemmen der Finger

- ▶ Nicht in den Scharnierbereich greifen.
- ▶ Schutzhandschuhe tragen.

Voraussetzung:

- ✔ Das Gerät ist spannungsfrei.
- ✔ Das Gerät ist von der Wasserversorgung getrennt.

4.6.1 Ausbauen des Türscharniers

1. Die beiden Schrauben lösen.
2. Die Tür demontieren.
3. Die Tür von außen nach innen demontieren.

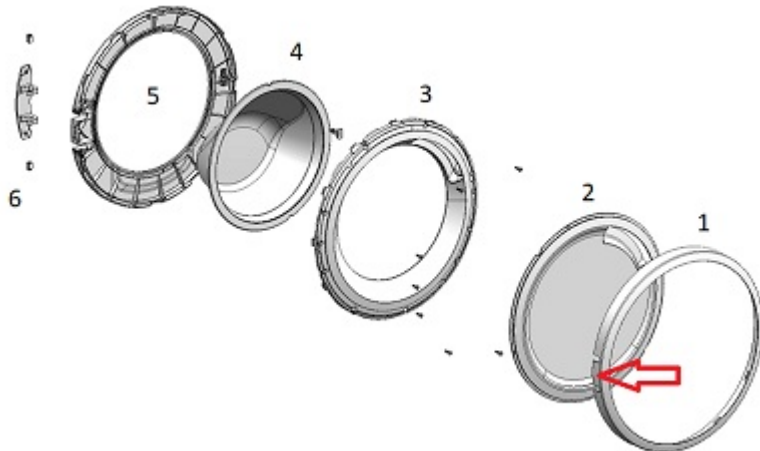



4. Das Türscharnier entfernen.

4.6.2 Einbauen des Türscharniers

- ▶ Der Einbau erfolgt in umgekehrter Reihenfolge.

4.7 Austauschen der Türdichtung

| | |
|--|--|
|  | <p>VORSICHT</p> <p>Scharfe Gehäusekanten! Schnittverletzungen</p> <ul style="list-style-type: none"> ▶ Schutzhandschuhe tragen. |
|--|--|

| | |
|--|--|
|  | <p>VORSICHT</p> <p>Risiko herabfallender Teile durch gelöste Schrauben! Verletzungsgefahr durch herabfallende Teile.</p> <ul style="list-style-type: none"> ▶ Die Komponenten gegen Herunterfallen sichern. |
|--|--|

| | |
|--|--|
|  | <p>ACHTUNG</p> <p>Risiko herabfallender Teile durch gelöste Schrauben! Gefahr der Beschädigung anderer Geräteteile bzw. von Beschädigungen im Haushalt des Kunden, z. B. des Bodens.</p> <ul style="list-style-type: none"> ▶ Die Komponenten gegen Herunterfallen sichern. |
|--|--|

Voraussetzung:

- ✓ Das Gerät ist spannungsfrei.
- ✓ Das Gerät ist von der Wasserversorgung getrennt.
- ✓ Das Gerät ist frei zugänglich.
- ✓ [Die Waschlittelschublade ist entfernt worden. → Seite 198](#)
- ✓ Bedienblende ist abgebaut.
- ✓ [Tür ist ausgebaut. → Seite 200](#)
- ✓ [Die untere Abdeckung ist entfernt worden. → Seite 208](#)

4.7.1 Ausbauen der Türdichtung

1. Halter der Trommelinnenbeleuchtung lösen.



2.

| | |
|---|--|
|  | <p>ACHTUNG</p> <p>Gefahr von Oberflächenschäden! Bei Verwendung ungeeigneter Werkzeuge kann die Geräteoberfläche beschädigt werden.</p> <ul style="list-style-type: none"> ▶ Für den Austausch des Spannrings dürfen ausschließlich Kunststoffwerkzeuge verwendet werden. |
|---|--|

Den Spannring mit einem Kunststoffwerkzeug von der Dichtung entfernen.

3. Die Türdichtung von der Frontblende lösen.
4. Den Kabelsteckverbinder von der Türverriegelung lösen.

Instandsetzen

5. Schrauben in angegebener Reihenfolge lösen.



6. Die Frontblende entfernen.

7. Alle Schlauchanschlüsse trennen.

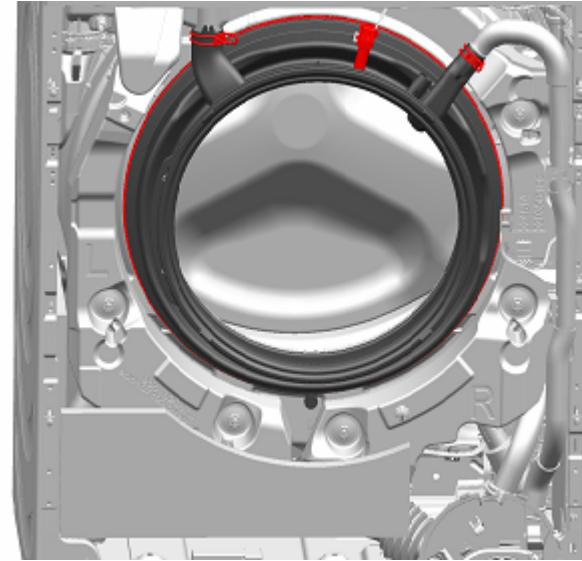

8. Die Türdichtung entfernen.

4.7.2 Einbauen der Türdichtung

► Der Einbau erfolgt in umgekehrter Reihenfolge.

4.8 Austauschen der Türverriegelung

Als Hersteller sind wir nach der Verordnung (EU) 2019/2023 verpflichtet, Verbrauchern die Türsicherung, einschließlich Reparaturanleitung, als Ersatzteil zur Verfügung zu stellen. Wir möchten jedoch darauf hinweisen, dass nach dem Austausch einer Türsicherung eine elektrotechnische Sicherheitsprüfung durch eine Elektrofachkraft erforderlich ist, bevor das Gerät in Betrieb genommen wird. Diese Person muss nachweislich gemäß den länderspezifischen Gesetzen, Vorschriften und Normen qualifiziert sein.

| | |
|--|---|
|  | <p style="text-align: center;">⚠️ GEFAHR</p> <p>Stromschlaggefahr durch spannungsführende Teile! Lebensgefahr durch Stromschlag bei unsachgemäßer Reparatur</p> <ul style="list-style-type: none"> ▶ Elektroteile sollten von einer Elektrofachkraft repariert werden. ▶ Nach der Reparatur muss eine Sicherheitsprüfung nach VDE 0701 oder länderspezifischen Vorschriften durchgeführt werden. |
|  | <p style="text-align: center;">⚠️ VORSICHT</p> <p>Scharfe Gehäusekanten! Schnittverletzungen</p> <ul style="list-style-type: none"> ▶ Schutzhandschuhe tragen. |
|  | <p style="text-align: center;">⚠️ WARNUNG</p> <p>Wegrutschen des gekippten Gerätes! Knochenbrüche / Quetschungen</p> <ul style="list-style-type: none"> ▶ Gerät gegen Wegrutschen sichern. |
|  | <p style="text-align: center;">⚠️ VORSICHT</p> <p>Risiko herabfallender Teile durch gelöste Schrauben! Verletzungsgefahr durch herabfallende Teile.</p> <ul style="list-style-type: none"> ▶ Die Komponenten gegen Herunterfallen sichern. |
|  | <p style="text-align: center;">⚠️ ACHTUNG</p> <p>Risiko herabfallender Teile durch gelöste Schrauben! Gefahr der Beschädigung anderer Geräteteile bzw. von Beschädigungen im Haushalt des Kunden, z. B. des Bodens.</p> <ul style="list-style-type: none"> ▶ Die Komponenten gegen Herunterfallen sichern. |

Voraussetzung:

- ✔ Das Gerät ist spannungsfrei.

- ✔ Das Gerät ist von der Wasserversorgung getrennt.
- ✔ Das Gerät ist frei zugänglich.
- ✔ Die Möbelfront ist demontiert worden.
- ✔ Bedienblende ist abgebaut.
- ✔ [Tür ist ausgebaut.](#) → [Seite 200](#)
- ✔ Der Spannung ist entfernt worden.
- ✔ Das Frontpanel ist entfernt worden.
- ✔ Türdichtung ist demontiert.

4.8.1 Türverriegelung demontieren

1. Den Stecker der Türverriegelung abziehen.
2. Die Türverriegelung lösen.



3. Die Türverriegelung entfernen.





4.8.2 Türverriegelung montieren

Die Türverriegelung muss sich in der richtigen Position befinden, um die ordnungsgemäße Notfall-Türöffnungsfunktion des Geräts sicherzustellen.



- ▶ Der Einbau erfolgt in umgekehrter Reihenfolge.

4.9 Austauschen der Trommelbeleuchtung

| | |
|--|---|
|  | VORSICHT Scharfe Gehäusekanten! Schnittverletzungen ▶ Schutzhandschuhe tragen. |
|  | WARNUNG Wegrutschen des gekippten Gerätes! Knochenbrüche / Quetschungen ▶ Gerät gegen Wegrutschen sichern. |
|  | VORSICHT Risiko herabfallender Teile durch gelöste Schrauben! Verletzungsgefahr durch herabfallende Teile. ▶ Die Komponenten gegen Herunterfallen sichern. |
|  | ACHTUNG Risiko herabfallender Teile durch gelöste Schrauben! Gefahr der Beschädigung anderer Geräteteile bzw. von Beschädigungen im Haushalt des Kunden, z. B. des Bodens. ▶ Die Komponenten gegen Herunterfallen sichern. |

Voraussetzung:

- ✔ Das Gerät ist spannungsfrei.
- ✔ Das Gerät ist von der Wasserversorgung getrennt.
- ✔ Das Gerät ist frei zugänglich.
- ✔ [Die Waschmittelschublade ist entfernt worden. → Seite 198](#)
- ✔ Bedienblende ist abgebaut.

4.9.1 Ausbauen der Trommelbeleuchtung

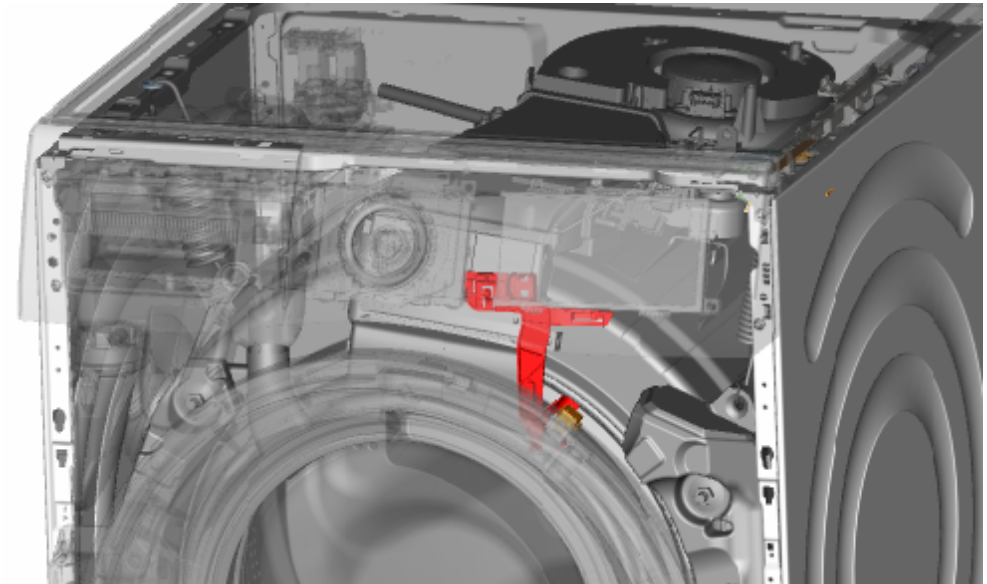

1. Die Trommelbeleuchtungshalterung aus dem Gerät ziehen.
2. Die elektrischen Anschlüsse trennen.
3. Die Trommelbeleuchtung aus der Trommelbeleuchtungshalterung entfernen.

4.9.2 Einbauen der Trommelbeleuchtung

- ▶ Der Einbau erfolgt in umgekehrter Reihenfolge.

4.10 Austauschen der unteren Abdeckung



Abb. 1: Abdeckung Bodengruppe

Voraussetzung:

- ✔ Das Gerät ist spannungsfrei.
- ✔ Das Gerät ist von der Wasserversorgung getrennt.
- ✔ Die Möbelfront ist demontiert worden.

4.10.1 Ausbauen der unteren Abdeckung

Voraussetzung:

- ✔ Das Gerät ist spannungsfrei.
 - ✔ Das Gerät ist von der Wasserversorgung getrennt.
1. Die untere Abdeckung entfernen.

2. Schlauch aus der Halterung lösen.



Instandsetzen

3. 1. Schrauben lösen (1).
2. Haltepunkt durch drücken nach unten lösen (2).

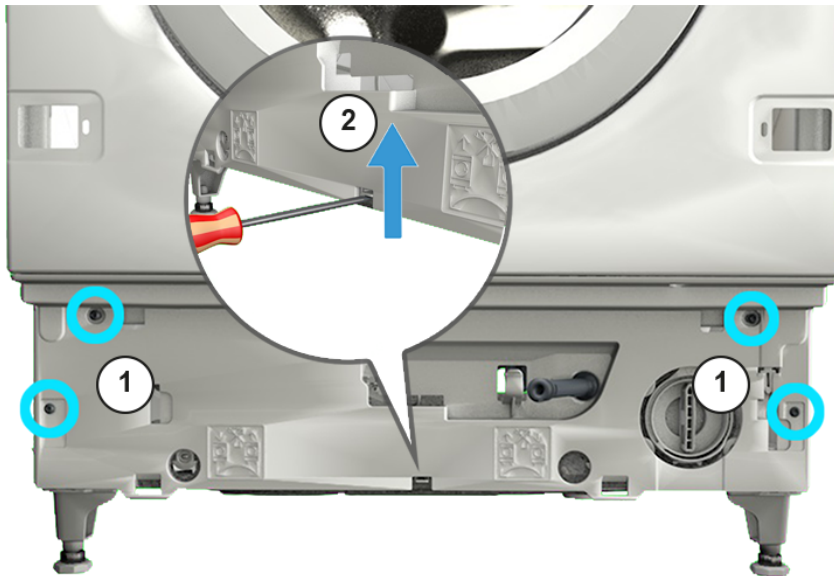

4. Abdeckung der Bodengruppe durch ziehen nach vorne abnehmen.

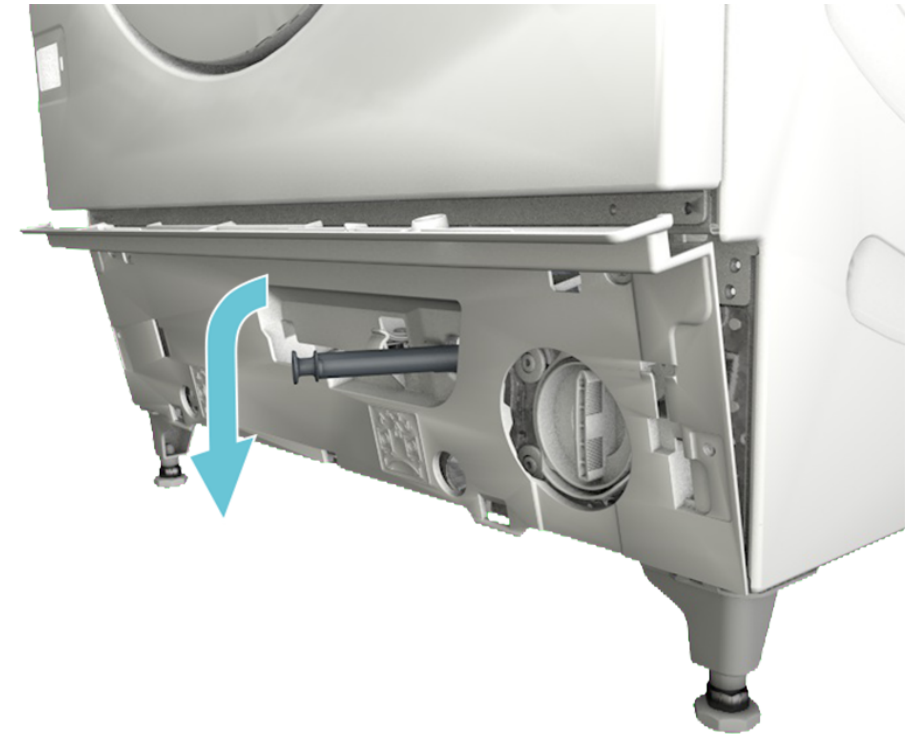

5. Schlauch aus der Abdeckung herausziehen.

4.10.2 Abdeckung montieren

- Der Einbau erfolgt in umgekehrter Reihenfolge.

4.11 Austauschen der Frontblende

| | |
|--|--|
|  | ⚠ VORSICHT |
| | Scharfe Gehäusekanten! Schnittverletzungen ▶ Schutzhandschuhe tragen. |

Voraussetzung:

- ✔ Das Gerät ist spannungsfrei.
- ✔ Das Gerät ist von der Wasserversorgung getrennt.
- ✔ Das Gerät ist frei zugänglich.
- ✔ Die Waschlittschublade ist entfernt worden. → [Seite 198](#)
- ✔ Die Möbelfront ist demontiert worden.
- ✔ Tür ist ausgebaut. → [Seite 200](#)
- ✔ Türdichtung ist demontiert.

4.11.1 Ausbauen der Frontblende

1. Halter der Trommelinnenbeleuchtung lösen.

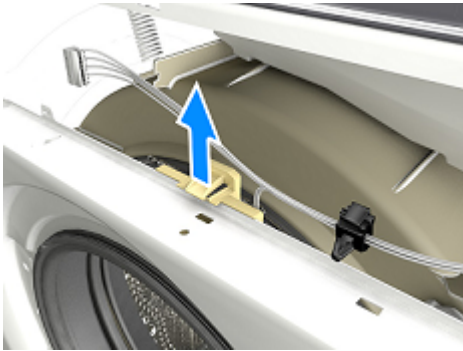

2.

| | |
|---|--|
|  | ⚠ VORSICHT |
| | Risiko herabfallender Teile durch gelöste Schrauben! Verletzungsgefahr durch herabfallende Teile. ▶ Die Komponenten gegen Herunterfallen sichern. |

| | |
|---|---|
|  | ACHTUNG |
| | Risiko herabfallender Teile durch gelöste Schrauben! Gefahr der Beschädigung anderer Geräteteile bzw. von Beschädigungen im Haushalt des Kunden, z. B. des Bodens. ▶ Die Komponenten gegen Herunterfallen sichern. |

Schrauben in angegebener Reihenfolge lösen.







3. Die Frontblende entfernen.

4.11.2 Einbauen der Frontblende

▶ Der Einbau erfolgt in umgekehrter Reihenfolge.

Υποδείξεις επισκευής - Πλυντήριο ρούχων

| | |
|--|------------|
|  Σχετικά με αυτό το έγγραφο | 213 |
| 1.1 Σημαντικές πληροφορίες | 213 |
| 1.1.1 Σκοπός | 213 |
| 1.2 Επεξήγηση συμβόλων | 213 |
| 1.2.1 Επίπεδα κινδύνου | 213 |
| 1.2.2 Σύμβολα κινδύνου | 213 |
| 1.2.3 Δομή των προειδοποιήσεων | 214 |
| 1.2.4 Γενικά σύμβολα | 214 |
|  Ασφάλεια | 215 |
| 2.1 Γενικές οδηγίες ασφαλείας | 215 |
| 2.1.1 Όλες οι οικιακές συσκευές | 215 |
|  Εργαλεία και βοηθήματα | 216 |
|  Επισκευή | 217 |
| 4.1 Αντικατάσταση μετώπης | 217 |
| 4.1.1 Αφαίρεση μετώπης | 217 |
| 4.1.2 Τοποθέτηση μετώπης | 218 |
| 4.2 Αντικατάσταση συρταριού απορρυπαντικού | 219 |
| 4.2.1 Αφαίρεση συρταριού απορρυπαντικού | 219 |
| 4.2.2 Τοποθέτηση συρταριού απορρυπαντικού | 219 |
| 4.3 Αντικατάσταση λαβής συρταριού απορρυπαντικού | 220 |
| 4.3.1 Αφαίρεση λαβής συρταριού απορρυπαντικού | 220 |
| 4.3.2 Τοποθέτηση λαβής συρταριού απορρυπαντικού | 220 |
| 4.4 Αντικατάσταση πόρτας | 221 |
| 4.4.1 Αφαίρεση πόρτας | 221 |
| 4.4.2 Τοποθέτηση πόρτας | 221 |
| 4.5 Αντικατάσταση εξαρτημάτων πόρτας | 222 |
| 4.5.1 Αφαίρεση εξαρτημάτων πόρτας | 222 |
| 4.5.2 Τοποθέτηση εξαρτημάτων πόρτας | 222 |
| 4.6 Αντικατάσταση μεντεσέ πόρτας | 223 |
| 4.6.1 Αφαίρεση μεντεσέ πόρτας | 223 |
| 4.6.2 Τοποθέτηση μεντεσέ πόρτας | 223 |
| 4.7 Αντικατάσταση στεγανοποιητικού πόρτας | 224 |
| 4.7.1 Αφαίρεση στεγανοποιητικού πόρτας | 224 |
| 4.7.2 Τοποθέτηση στεγανοποιητικού πόρτας | 225 |

| | |
|--------------------------------------|-----|
| 4.8 Αντικατάσταση ασφάλειας πόρτας | 226 |
| 4.8.1 Αφαίρεση ασφάλειας πόρτας | 226 |
| 4.8.2 Τοποθέτηση ασφάλειας πόρτας | 227 |
| 4.9 Αντικατάσταση φωτισμού τυμπάνου | 228 |
| 4.9.1 Αφαίρεση φωτισμού τυμπάνου | 228 |
| 4.9.2 Τοποθέτηση φωτισμού τυμπάνου | 228 |
| 4.10 Αντικατάσταση κάτω καλύμματος | 229 |
| 4.10.1 Αφαίρεση κάτω καλύμματος | 229 |
| 4.10.2 Τοποθέτηση καλύμματος | 230 |
| 4.11 Αντικατάσταση μπροστινού πίνακα | 231 |
| 4.11.1 Αφαίρεση μπροστινού πίνακα | 231 |
| 4.11.2 Τοποθέτηση μπροστινού πίνακα | 232 |

i Σχετικά με αυτό το έγγραφο

1.1 Σημαντικές πληροφορίες

1.1.1 Σκοπός

Αυτές οι συμβουλές επισκευών υποστηρίζουν τους καταναλωτές στην επισκευή των συσκευών από τους ίδιους, σύμφωνα με τον ισχύοντα κανονισμό οικολογικού σχεδιασμού (από τις 03/2021).



Περιέχουν πληροφορίες για την αντικατάσταση ορισμένων ανταλλακτικών, συμπεριλαμβανομένων προειδοποιήσεων και κινδύνων.

Σε περίπτωση ερωτήσεων, επικοινωνήστε με το τμήμα εξυπηρέτησης πελατών της εταιρείας μας. Φέρουμε ευθύνη για τις ζημιές εάν οι συμβουλές επισκευής έχουν ακολουθηθεί σωστά.

1.2 Επεξήγηση συμβόλων

1.2.1 Επίπεδα κινδύνου

Τα επίπεδα προειδοποίησης ασφάλειας αποτελούνται από ένα σύμβολο και μια λέξη. Η λέξη προειδοποίησης προσδιορίζει τη σοβαρότητα του κινδύνου.





| Επίπεδο προειδοποίησης | Σημασία |
|--|---|
|  ΚΙΝΔΥΝΟΣ | Η μη τήρηση του προειδοποιητικού μηνύματος θα οδηγήσει σε θάνατο ή σε σοβαρούς τραυματισμούς. |
|  ΠΡΟΕΙΔΟΠΟΙΗΣΗ | Η μη τήρηση του προειδοποιητικού μηνύματος θα μπορούσε να οδηγήσει σε θάνατο ή σε σοβαρούς τραυματισμούς. |
|  ΠΡΟΣΟΧΗ | Η μη τήρηση του προειδοποιητικού μηνύματος θα μπορούσε να οδηγήσει σε μικρούς τραυματισμούς. |
|  ΠΡΟΣΟΧΗ! | Η μη τήρηση του προειδοποιητικού μηνύματος θα μπορούσε να οδηγήσει σε υλικές ζημιές της ιδιοκτησίας. |

Πίνακας 1: Επίπεδα κινδύνου





1.2.2 Σύμβολα κινδύνου

Τα σύμβολα κινδύνου είναι συμβολικές αναπαραστάσεις που δίνουν μια ένδειξη για το είδος του κινδύνου.

Τα ακόλουθα σύμβολα κινδύνου χρησιμοποιούνται στο παρόν έγγραφο:

| Σύμβολο κινδύνου | Σημασία |
|---|-------------------------------|
|  | Γενικό προειδοποιητικό μήνυμα |
|  | Κίνδυνος από ηλεκτρική τάση |
|  | Κίνδυνος έκρηξης |
|  | Κίνδυνος κοψίματος |

i Σχετικά με αυτό το έγγραφο

| Σύμβολο κινδύνου | Σημασία |
|--|---------------------------------------|
|  | Κίνδυνος σύνθλιψης |
|  | Κίνδυνος από καυτές επιφάνειες |
|  | Κίνδυνος από ισχυρό μαγνητικό πεδίο |
|  | Κίνδυνος από μη ιονίζουσα ακτινοβολία |

Πίνακας 2: Σύμβολα κινδύνου

1.2.3 Δομή των προειδοποιήσεων

.Οι προειδοποιήσεις σε αυτό το έγγραφο έχουν μια τυποποιημένη εμφάνιση και μια τυποποιημένη δομή.

| | |
|--|-------------------|
|  | ⚠ ΚΙΝΔΥΝΟΣ |
| Είδος και πηγή κινδύνου! | |
| Πιθανές συνέπειες εάν αγνοήσετε τον κίνδυνο/την προειδοποίηση. | |
| ▶ Μέτρα και απαγορεύσεις για την πρόληψη του κινδύνου. | |

Το παρακάτω παράδειγμα δείχνει μια προειδοποίηση που προειδοποιεί κατά της ηλεκτροπληξίας λόγω ηλεκτροφόρων μερών. Αναφέρεται το μέτρο για την αποφυγή του κινδύνου.

| | |
|--|-------------------|
|  | ⚠ ΚΙΝΔΥΝΟΣ |
| Κίνδυνος ηλεκτροπληξίας λόγω ηλεκτροφόρων μερών! | |
| Θάνατος από ηλεκτροπληξία | |
| ▶ Αποσυνδέετε τις συσκευές από την παροχή ηλεκτρικού ρεύματος τουλάχιστον 60 δευτερόλεπτα πριν ξεκινήσετε τις επισκευές. | |

1.2.4 Γενικά σύμβολα

Τα ακόλουθα γενικά σύμβολα χρησιμοποιούνται στο παρόν έγγραφο:

| Γεν. σύμβολο | Σημασία |
|---|--|
|  | Ταυτοποίηση μιας ειδικής συμβουλής (κειμένου ή/και γραφικών) |
|  | Ταυτοποίηση μιας ειδικής συμβουλής (μόνο κειμένου) |
|  | Ταυτοποίηση συνδέσμου ή εκπαιδευτικού βίντεο |
|  | Ταυτοποίηση απαραίτητων εργαλείων |
|  | Ταυτοποίηση απαραίτητων προϋποθέσεων |
|  | Ταυτοποίηση μιας συνθήκης (αν ..., κατόπιν ...) |
|  | Ταυτοποίηση αποτελέσματος |
|  | Ταυτοποίηση ενός πλήκτρου ή κουμπιού |
|  | Ταυτοποίηση ενός κωδικού ανταλλακτικού |
|  | Ταυτοποίηση εμφανιζόμενου κειμένου/παραθύρου (στην οθόνη της συσκευής) |

Πίνακας 3: Γενικά σύμβολα

2.1 Γενικές οδηγίες ασφαλείας

2.1.1 Όλες οι οικιακές συσκευές

Κίνδυνος ηλεκτροπληξίας λόγω ηλεκτροφόρων μερών!

- Τα σφάλματα από επισκευές σε ηλεκτρικά εξαρτήματα μπορεί να προκαλέσουν ηλεκτροπληξία!
- Αποσυνδέστε τη συσκευή από την πρίζα για τουλάχιστον 60 δευτερόλεπτα πριν από την έναρξη των εργασιών.
- Μετά την επισκευή πραγματοποιήστε έλεγχο ασφαλείας σύμφωνα με το VDE 0701 ή κανονισμούς της συγκεκριμένης χώρας.

Κίνδυνος τραυματισμού από κοφτερές άκρες!

- Φοράτε προστατευτικά γάντια.

Κίνδυνος σύνθλιψης κατά την επισκευή, συντήρηση, αντιμετώπιση προβλημάτων και το σέρβις από βαριά και κινούμενα μέρη

- Φοράτε προστατευτικά υποδήματα.
- Ασφαλίστε τα βαριά μέρη από πτώση.
- Μην προσαρτάτε μέρη του πλαισίου στα κινούμενα μέρη.







Κίνδυνος για την ασφάλεια/τη λειτουργία της συσκευής!

- Χρησιμοποιείτε μόνο γνήσια ανταλλακτικά.

Κίνδυνος πρόκλησης βλάβης σε μέρη ευαίσθητα στον στατικό ηλεκτρισμό (ESDs)!

- Μην αγγίζετε τις μονάδες, συμπεριλαμβανομένων των συνδέσεων και των αγωγών των πλακετών.

Εργαλεία και βοηθήματα

| Όνομασία | Λεπτομέριες | Εικόνες |
|--|---|--|
| Βοηθητικό εργαλείο [15000155] | Εργαλείο λυσίματος πλαστικών τμημάτων |  |
| Κατσαβίδι Torx T20 με τρύπα [00340764] | 100 mm, για βίδες με κοπίλια |  |
| Ροπόκλειδο [15000441] | Ροπόκλειδο 20 - 100 Nm | |
| Πλακέ κατσαβίδι [00340854] | Λεπίδα 3,5 mm x 0,6 mm x 100 mm, Προστατευτική μόνωση 1000 V AC |  |
| Πλακέ κατσαβίδι [00340855] | Λεπίδα 5,5 mm x 1,0 mm x 125 mm, Προστατευτική μόνωση 1000 V AC |  |
| Μυτοσίμπιδο, γωνιαστό [00341269] | Μήκος 200 mm |  |
| Κοφτάκι [00342182] | Μήκος: 200 mm |  |

| Όνομασία | Λεπτομέριες | Εικόνες |
|---|---|---|
| Συνδυαστικό κλειδί (Γερμανοπολύγωνο) [00340811] | Νούμερο κλειδιού (Γερμανοπολύγωνο) 10°mm, M6 |  |
| Combination wrench [00340814] | Νούμερο κλειδιού (Γερμανοπολύγωνο) 13°mm, M8 |  |
| Συνδυαστικό κλειδί (Γερμανοπολύγωνο) [00340817] | Νούμερο κλειδιού (Γερμανοπολύγωνο) 17 mm, M10 |  |
| Συνδυαστικό κλειδί (Γερμανοπολύγωνο) [15000459] | Νούμερο κλειδιού (Γερμανοπολύγωνο) 16°mm, M10 |  |

4.1 Αντικατάσταση μετώπης



⚠️ ΠΡΟΣΟΧΗ

Αιχμηρά άκρα περιβλήματος!
Τραυματισμοί από κοπή
▶ Φοράτε προστατευτικά γάντια.



⚠️ ΠΡΟΕΙΔΟΠΟΙΗΣΗ

Ολίσθηση κεκλιμένων συσκευών!
Κατάγματα οστών/τραυματισμοί σύνθλιψης
▶ Ασφαλίστε τις συσκευές από ολίσθηση.



⚠️ ΠΡΟΣΟΧΗ

Κίνδυνοι από πτώση μερών εξαιτίας χαλαρών βιδών!
Τραυματισμός εξαιτίας πτώσης τμημάτων.
▶ Ασφαλίστε τα εξαρτήματα από πτώση.



ΠΡΟΣΟΧΗ!

Κίνδυνων από πτώση εξαρτημάτων εξαιτίας χαλαρών βιδών!
Ζημιά σε άλλα μέρη της συσκευής ή στην οικία του πελάτη, π.χ. δάπεδο.
▶ Ασφαλίστε τα εξαρτήματα από πτώση.

Προϋπόθεση:

- ✔ Η συσκευή είναι αποσυνδεδεμένη από την παροχή τροφοδοσίας.
- ✔ Η συσκευή είναι αποσυνδεδεμένη από την παροχή νερού.
- ✔ Η πρόσβαση στις συσκευές είναι ελεύθερη.
- ✔ [Έχει αφαιρεθεί το συρτάρι απορρυπαντικού.→219](#)

4.1.1 Αφαίρεση μετώπης

1. Απασφαλίστε το στοιχείο συγκράτησης (1).
2. Αφαιρέστε το κάλυμμα (2).

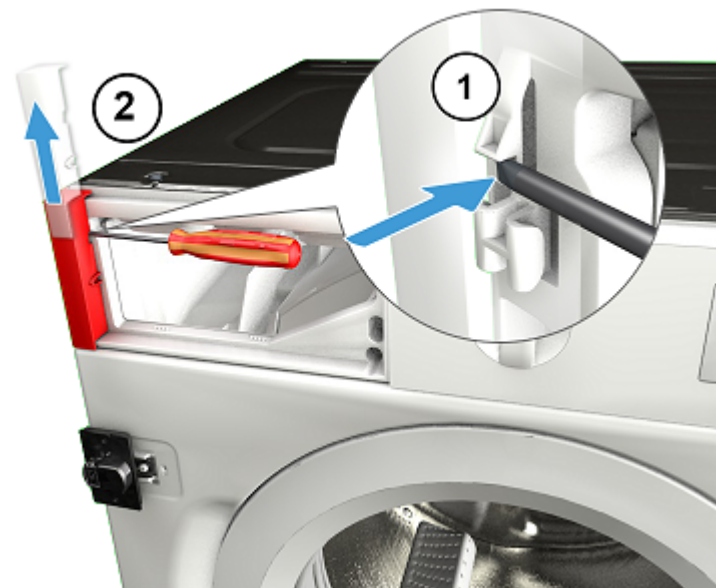

2. Αφαιρέστε τις βίδες.



3. 1. Απασφαλίστε τα στοιχεία συγκράτησης (1, 2).
2. Τραβήξτε τη μετώπη στο μπροστινό μέρος (3).

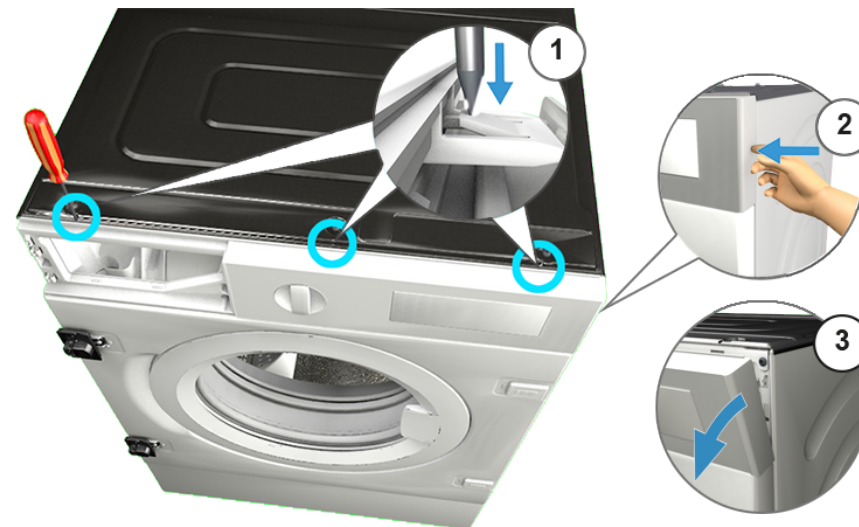

4. Αφαιρέστε τη μετώπη.

4.1.2 Τοποθέτηση μετώπης

► Εγκαταστήστε με την αντίθετη σειρά.

4.2 Αντικατάσταση συρταριού απορρυπαντικού

Προϋπόθεση:

- ✓ Η συσκευή είναι αποσυνδεδεμένη από την παροχή τροφοδοσίας.
- ✓ Η συσκευή είναι αποσυνδεδεμένη από την παροχή νερού.

4.2.1 Αφαίρεση συρταριού απορρυπαντικού

1. Τραβήξτε έξω το συρτάρι απορρυπαντικού.
2. 1. Πιέστε κάτω το ένθετο (1).
2. Αφαιρέστε το συρτάρι απορρυπαντικού (2).

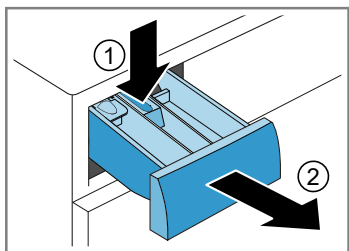

4.2.2 Τοποθέτηση συρταριού απορρυπαντικού

- ▶ Εγκαταστήστε με την αντίθετη σειρά.

4.3 Αντικατάσταση λαβής συρταριού απορρυπαντικού

Προϋπόθεση:

- ✔ Η συσκευή είναι αποσυνδεδεμένη από την παροχή τροφοδοσίας.
- ✔ Η συσκευή είναι αποσυνδεδεμένη από την παροχή νερού.
- ✔ [Έχει αφαιρεθεί το συρτάρι απορρυπαντικού.→219](#)

4.3.1 Αφαίρεση λαβής συρταριού απορρυπαντικού

1. Απασφαλίστε τα στοιχεία συγκράτησης.

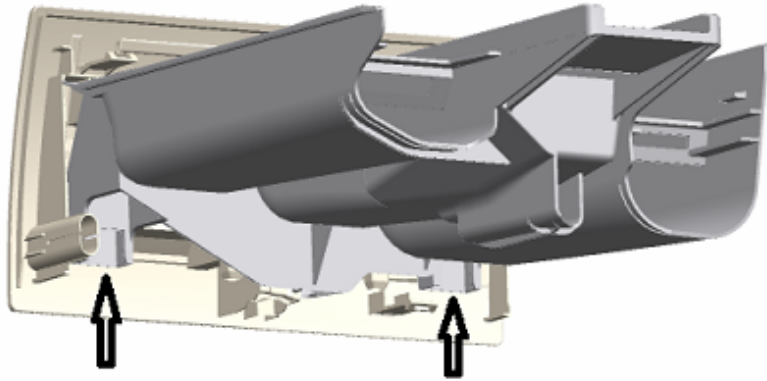

2. Αφαιρέστε τη λαβή συρταριού απορρυπαντικού.

4.3.2 Τοποθέτηση λαβής συρταριού απορρυπαντικού

- ▶ Εγκαταστήστε με την αντίθετη σειρά.

4.4 Αντικατάσταση πόρτας



ΠΡΟΣΟΧΗ

Ανοίξτε την περιοχή με τους μεντεσέδες!

Σύνθλιψη/παγίδευση δακτύλων

- ▶ Μην αγγίζετε την περιοχή με τους μεντεσέδες.
- ▶ Φοράτε προστατευτικά γάντια.

Προϋπόθεση:

- ✔ Η συσκευή είναι αποσυνδεδεμένη από την παροχή τροφοδοσίας.
- ✔ Η συσκευή είναι αποσυνδεδεμένη από την παροχή νερού.
- ✔ Η πόρτα είναι ανοιχτή.
- ✔ Έχει αφαιρεθεί η πρόσοψη του ντουλαπιού.

4.4.1 Αφαίρεση πόρτας

1.



ΠΡΟΣΟΧΗ!

Κίνδυνων από πτώση εξαρτημάτων εξαιτίας χαλαρών βιδών!

Ζημιά σε άλλα μέρη της συσκευής ή στην οικία του πελάτη, π.χ. δάπεδο.

- ▶ Ασφαλίστε τα εξαρτήματα από πτώση.



ΠΡΟΣΟΧΗ

Κίνδυνοι από πτώση μερών εξαιτίας χαλαρών βιδών!

Τραυματισμός εξαιτίας πτώσης τμημάτων.

- ▶ Ασφαλίστε τα εξαρτήματα από πτώση.

Αφαιρέστε τις βίδες (1).

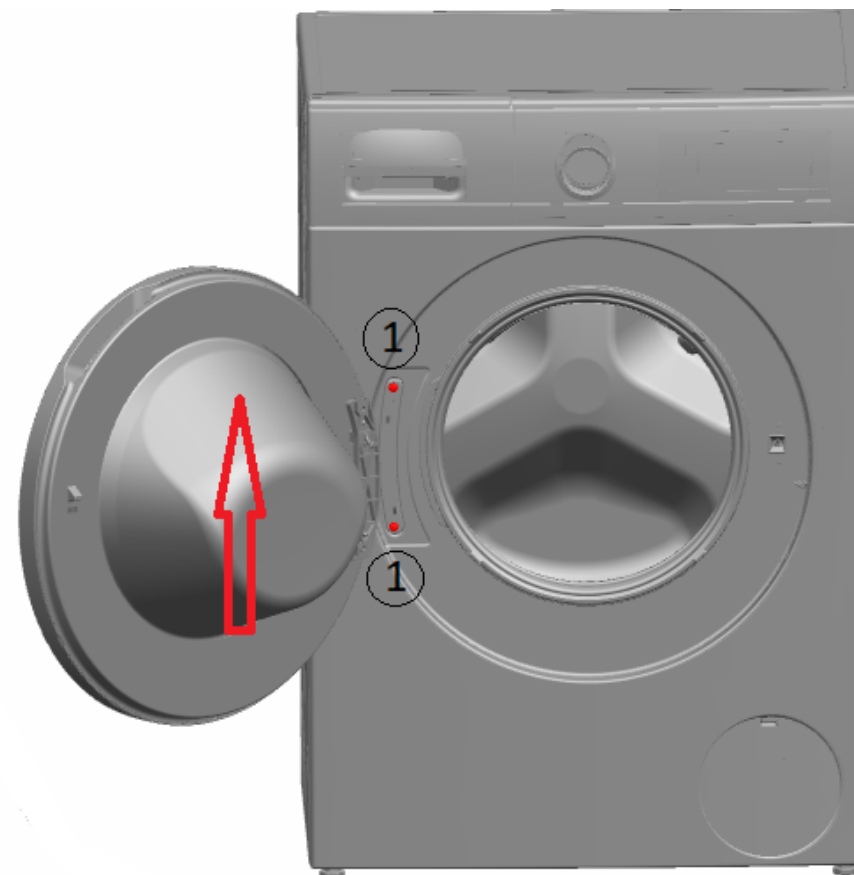

2. Αφαιρέστε την πόρτα προς τα επάνω.

4.4.2 Τοποθέτηση πόρτας

- ▶ Εγκαταστήστε με την αντίθετη σειρά.

4.5 Αντικατάσταση εξαρτημάτων πόρτας



⚠️ ΠΡΟΣΟΧΗ

Ανοίξτε την περιοχή με τους μεντεσέδες!

Σύνθλιψη/παγίδευση δακτύλων

- ▶ Μην αγγίζετε την περιοχή με τους μεντεσέδες.
- ▶ Φοράτε προστατευτικά γάντια.

Προϋπόθεση:

- ✔ Η συσκευή είναι αποσυνδεδεμένη από την παροχή τροφοδοσίας.
- ✔ Η συσκευή είναι αποσυνδεδεμένη από την παροχή νερού.
- ✔ Έχει αφαιρεθεί η πρόσοψη του ντουλαπιού.
- ✔ [Η πόρτα έχει αφαιρεθεί. → 221](#)

4.5.1 Αφαίρεση εξαρτημάτων πόρτας

- ▶ Αποσυναρμολογήστε την πόρτα από έξω προς τα μέσα.

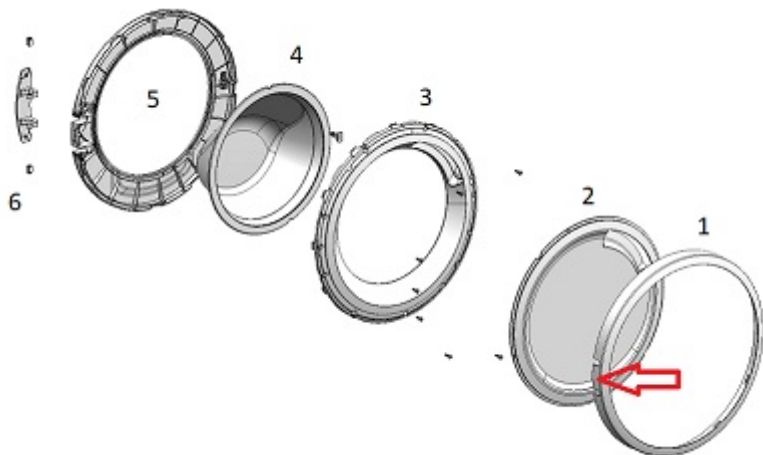

4.5.2 Τοποθέτηση εξαρτημάτων πόρτας

- ▶ Εγκαταστήστε με την αντίθετη σειρά.

4.6 Αντικατάσταση μεντεσέ πόρτας



ΠΡΟΣΟΧΗ

Ανοίξτε την περιοχή με τους μεντεσέδες!

Σύνθλιψη/παγίδευση δακτύλων

- ▶ Μην αγγίζετε την περιοχή με τους μεντεσέδες.
- ▶ Φοράτε προστατευτικά γάντια.

Προϋπόθεση:

- ✔ Η συσκευή είναι αποσυνδεδεμένη από την παροχή τροφοδοσίας.
- ✔ Η συσκευή είναι αποσυνδεδεμένη από την παροχή νερού.

4.6.1 Αφαίρεση μεντεσέ πόρτας

1. Απελευθερώστε δύο βίδες.
2. Αφαιρέστε την πόρτα.
3. Αποσυναρμολογήστε την πόρτα από έξω προς τα μέσα.

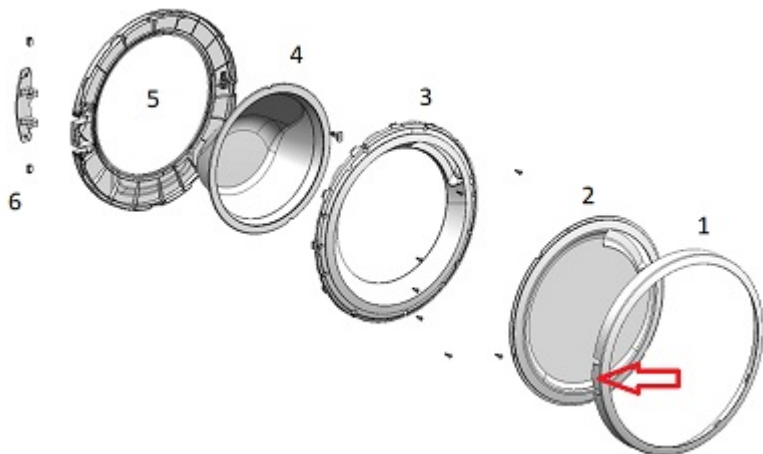



4. Αφαιρέστε τον μεντεσέ της πόρτας.

4.6.2 Τοποθέτηση μεντεσέ πόρτας

- ▶ Εγκαταστήστε με την αντίθετη σειρά.

4.7 Αντικατάσταση στεγανοποιητικού πόρτας

| | |
|--|---|
|  | ⚠️ ΠΡΟΣΟΧΗ Αιχμηρά άκρα περιβλήματος! Τραυματισμοί από κοπή ▶ Φοράτε προστατευτικά γάντια. |
|--|---|

| | |
|--|--|
|  | ⚠️ ΠΡΟΣΟΧΗ Κίνδυνοι από πτώση μερών εξαιτίας χαλαρών βιδών! Τραυματισμός εξαιτίας πτώσης τμημάτων. ▶ Ασφαλίστε τα εξαρτήματα από πτώση. |
|--|--|

| | |
|--|---|
|  | ΠΡΟΣΟΧΗ! Κίνδυνων από πτώση εξαρτημάτων εξαιτίας χαλαρών βιδών! Ζημιά σε άλλα μέρη της συσκευής ή στην οικία του πελάτη, π.χ. δάπεδο. ▶ Ασφαλίστε τα εξαρτήματα από πτώση. |
|--|---|

Προϋπόθεση:

- ✔ Η συσκευή είναι αποσυνδεδεμένη από την παροχή τροφοδοσίας.
- ✔ Η συσκευή είναι αποσυνδεδεμένη από την παροχή νερού.
- ✔ Η πρόσβαση στις συσκευές είναι ελεύθερη.
- ✔ [Έχει αφαιρεθεί το συρτάρι απορρυπαντικού.→219](#)
- ✔ Έχει αφαιρεθεί η μετώπη.
- ✔ [Η πόρτα έχει αφαιρεθεί.→221](#)
- ✔ [Το κάτω κάλυμμα έχει αφαιρεθεί.→229](#)

4.7.1 Αφαίρεση στεγανοποιητικού πόρτας

1. Λύστε τον συγκρατητή του φωτισμού τυμπάνου.

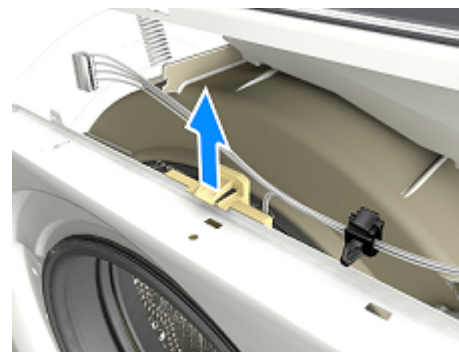

2.

| | |
|---|--|
|  | ΠΡΟΣΟΧΗ! Κίνδυνος κατεστραμμένης επιφάνειας! Η επιφάνεια της συσκευής μπορεί να γρατσουνιστεί από ακατάλληλα εργαλεία. ▶ Χρησιμοποιείτε μόνο πλαστικά εργαλεία για την αντικατάσταση του δακτυλίου τάνυσης. |
|---|--|

Αφαιρέστε τον δακτύλιο έντασης από την τσιμούχα με πλαστικό εργαλείο.

3. Βγάλτε το στεγανοποιητικό πόρτας από τον μπροστινό πίνακα.
4. Βγάλτε τον συνδετήρα καλωδίου από την ασφάλεια πόρτας.

5. Λύστε τις βίδες με την υποδεικνυόμενη σειρά.



6. Αφαιρέστε το μπροστινό πλαίσιο.

7. Αποσυνδέστε όλες τις συνδέσεις εύκαμπτου σωλήνα.

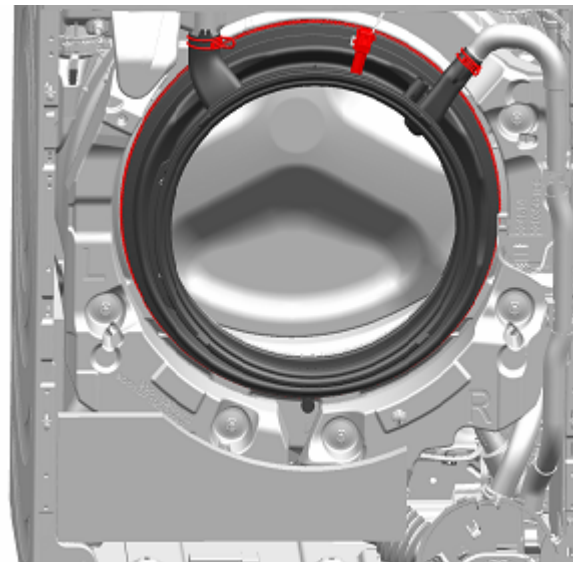

8. Αφαιρέστε το στεγανοποιητικό της πόρτας.

4.7.2 Τοποθέτηση στεγανοποιητικού πόρτας

► Εγκαταστήστε με την αντίθετη σειρά.

4.8 Αντικατάσταση ασφάλειας πόρτας

Ως κατασκευαστής, υποχρεούμαστε να παρέχουμε στους πελάτες την ανταλλακτική ασφάλεια πόρτας, συμπεριλαμβανομένων των οδηγιών επισκευής σύμφωνα με τον Κανονισμό (ΕΕ) 2019/2023. Ωστόσο, θα θέλαμε να επισημάνουμε ότι μετά την αντικατάσταση της ασφάλειας πόρτας, απαιτείται ένας έλεγχος ηλεκτροτεχνικής ασφάλειας από εκπαιδευμένο ηλεκτρολόγο πριν τεθεί σε λειτουργία η συσκευή. Αυτό το άτομο πρέπει να είναι αποδεδειγμένα εκπαιδευμένο σύμφωνα με τους νόμους, τους κανονισμούς και τα πρότυπα της συγκεκριμένης χώρας.

| | |
|--|--|
|  | ⚠ ΚΙΝΔΥΝΟΣ |
| | <p>Κίνδυνος ηλεκτροπληξίας λόγω ηλεκτροφόρων μερών! Κίνδυνος για τη ζωή από ηλεκτροπληξία σε περίπτωση ακατάλληλης επισκευής</p> <ul style="list-style-type: none"> ▶ Τα ηλεκτρικά μέρη πρέπει να επισκευάζονται από εκπαιδευμένους ηλεκτρολόγους. ▶ Μετά την επισκευή πραγματοποιήστε έλεγχο ασφάλειας σύμφωνα με το VDE 0701 ή κανονισμούς της συγκεκριμένης χώρας. |

| | |
|--|---|
|  | ⚠ ΠΡΟΣΟΧΗ |
| | <p>Αιχμηρά άκρα περιβλήματος! Τραυματισμοί από κοπή</p> <ul style="list-style-type: none"> ▶ Φοράτε προστατευτικά γάντια. |

| | |
|---|---|
|  | ⚠ ΠΡΟΕΙΔΟΠΟΙΗΣΗ |
| | <p>Ολίσθηση κεκλιμένων συσκευών! Κατάγματα οστών/τραυματισμοί σύνθλιψης</p> <ul style="list-style-type: none"> ▶ Ασφαλίστε τις συσκευές από ολίσθηση. |

| | |
|--|--|
|  | ⚠ ΠΡΟΣΟΧΗ |
| | <p>Κίνδυνοι από πτώση μερών εξαιτίας χαλαρών βιδών! Τραυματισμός εξαιτίας πτώσης τμημάτων.</p> <ul style="list-style-type: none"> ▶ Ασφαλίστε τα εξαρτήματα από πτώση. |

| | |
|--|---|
|  | ΠΡΟΣΟΧΗ! |
| | <p>Κίνδυνων από πτώση εξαρτημάτων εξαιτίας χαλαρών βιδών! Ζημιά σε άλλα μέρη της συσκευής ή στην οικία του πελάτη, π.χ. δάπεδο.</p> <ul style="list-style-type: none"> ▶ Ασφαλίστε τα εξαρτήματα από πτώση. |

Προϋπόθεση:

- ✔ Η συσκευή είναι αποσυνδεδεμένη από την παροχή τροφοδοσίας.
- ✔ Η συσκευή είναι αποσυνδεδεμένη από την παροχή νερού.
- ✔ Η πρόσβαση στις συσκευές είναι ελεύθερη.
- ✔ Έχει αφαιρεθεί η πρόσοψη του ντουλαπιού.
- ✔ Έχει αφαιρεθεί η μετώπη.
- ✔ [Η πόρτα έχει αφαιρεθεί. → 221](#)
- ✔ Έχει αφαιρεθεί ο δακτύλιος τάνυσης.
- ✔ Έχει αφαιρεθεί ο μπροστινός πίνακας.
- ✔ Έχει αφαιρεθεί το στεγανοποιητικό πόρτας.

4.8.1 Αφαίρεση ασφάλειας πόρτας

1. Αποσυνδέστε το βύσμα ασφάλειας πόρτας.
2. Απασφαλίστε την ασφάλεια πόρτας.



3. Αφαιρέστε την ασφάλεια πόρτας.





4.8.2 Τοποθέτηση ασφάλειας πόρτας

Η ασφάλεια πόρτας πρέπει να βρίσκεται στη σωστή θέση για να είναι βέβαιη η λειτουργία ανοίγματος της πόρτας έκτακτης ανάγκης της συσκευής.



- ▶ Εγκαταστήστε με την αντίθετη σειρά.

4.9 Αντικατάσταση φωτισμού τυμπάνου

| | |
|--|---|
|  | ⚠️ ΠΡΟΣΟΧΗ Αιχμηρά άκρα περιβλήματος! Τραυματισμοί από κοπή ▶ Φοράτε προστατευτικά γάντια. |
|  | ⚠️ ΠΡΟΕΙΔΟΠΟΙΗΣΗ Ολίσθηση κεκλιμένων συσκευών! Κατάγματα οστών/τραυματισμοί σύνθλιψης ▶ Ασφαλίστε τις συσκευές από ολίσθηση. |
|  | ⚠️ ΠΡΟΣΟΧΗ Κίνδυνοι από πτώση μερών εξαιτίας χαλαρών βιδών! Τραυματισμός εξαιτίας πτώσης τμημάτων. ▶ Ασφαλίστε τα εξαρτήματα από πτώση. |
|  | ΠΡΟΣΟΧΗ! Κίνδυνων από πτώση εξαρτημάτων εξαιτίας χαλαρών βιδών! Ζημιά σε άλλα μέρη της συσκευής ή στην οικία του πελάτη, π.χ. δάπεδο. ▶ Ασφαλίστε τα εξαρτήματα από πτώση. |

Προϋπόθεση:

- ✔ Η συσκευή είναι αποσυνδεμένη από την παροχή τροφοδοσίας.
- ✔ Η συσκευή είναι αποσυνδεμένη από την παροχή νερού.
- ✔ Η πρόσβαση στις συσκευές είναι ελεύθερη.
- ✔ [Έχει αφαιρεθεί το συρτάρι απορρυπαντικού.→219](#)
- ✔ Έχει αφαιρεθεί η μετώπη.

4.9.1 Αφαίρεση φωτισμού τυμπάνου

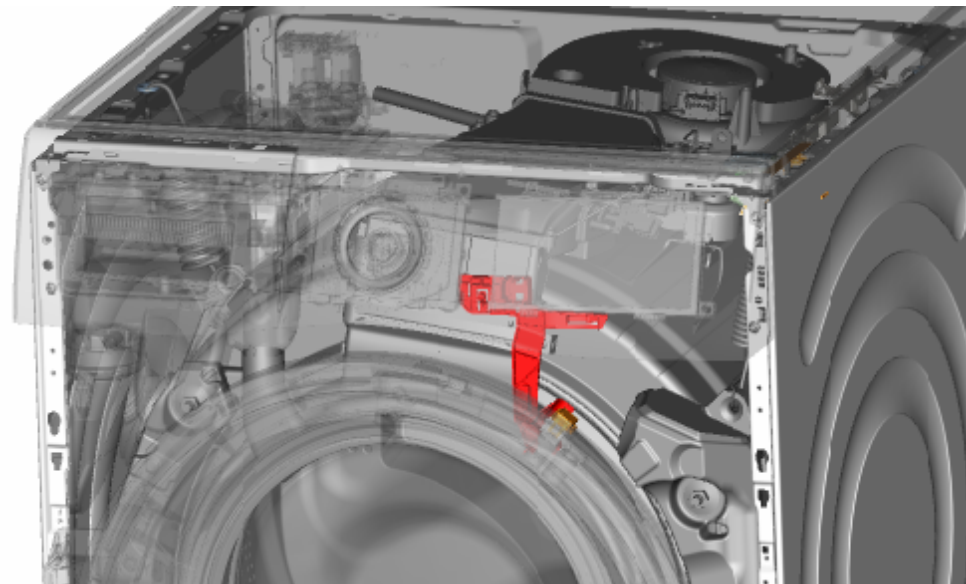

1. Αφαιρέστε τη βάση του φωτισμού τυμπάνου από τη συσκευή.
2. Αποσυνδέστε τις ηλεκτρικές συνδέσεις.
3. Αφαιρέστε τον φωτισμό τυμπάνου από τη βάση του φωτισμού τυμπάνου.

4.9.2 Τοποθέτηση φωτισμού τυμπάνου

- ▶ Εγκαταστήστε με την αντίθετη σειρά.

4.10 Αντικατάσταση κάτω καλύμματος



Εικ. 1: Κάλυμμα ομάδας κατώτερου σημείου

Προϋπόθεση:

- ✔ Η συσκευή είναι αποσυνδεδεμένη από την παροχή τροφοδοσίας.
- ✔ Η συσκευή είναι αποσυνδεδεμένη από την παροχή νερού.
- ✔ Έχει αφαιρεθεί η πρόσοψη του ντουλαπιού.

4.10.1 Αφαίρεση κάτω καλύμματος

Προϋπόθεση:

- ✔ Η συσκευή είναι αποσυνδεδεμένη από την παροχή τροφοδοσίας.
- ✔ Η συσκευή είναι αποσυνδεδεμένη από την παροχή νερού.

1. Αφαιρέστε το κάτω κάλυμμα.

2. Αποσυνδέστε τον εύκαμπτο σωλήνα από τη βάση.

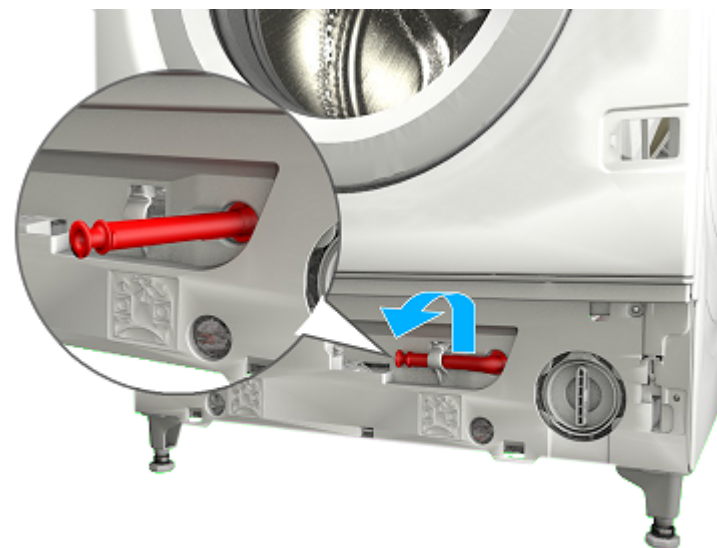

3. 1. Ξεβιδώστε τη βίδα (1).
2. Πιέστε στο σημείο συγκράτησης και αφαιρέστε προς τα κάτω (2).

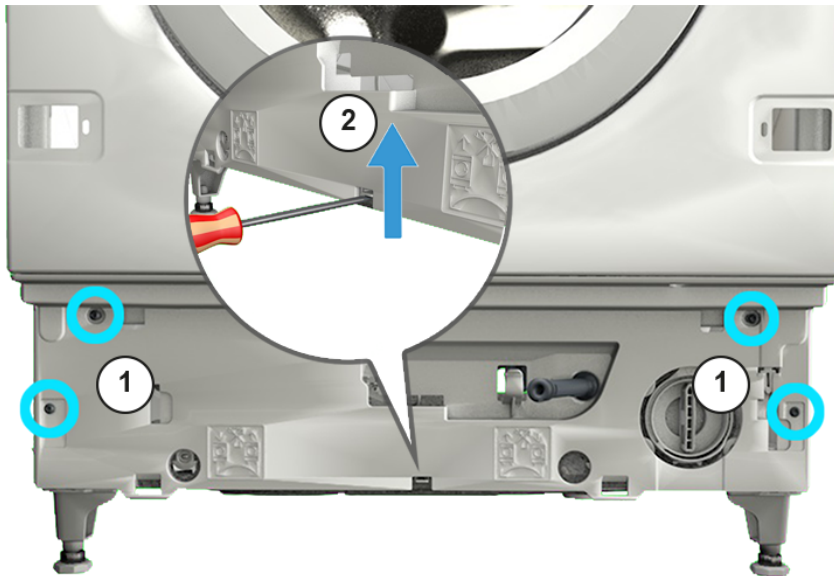

4. Τραβήξτε το κάτω κάλυμμα ομάδα και αφαιρέστε προς τα εμπρός.



5. Τραβήξτε τον εύκαμπτο σωλήνα από το κάλυμμα.

4.10.2 Τοποθέτηση καλύμματος

- Εγκαταστήστε με την αντίθετη σειρά.

4.11 Αντικατάσταση μπροστινού πίνακα

| | |
|--|--|
|  | ΠΡΟΣΟΧΗ Αιχμηρά άκρα περιβλήματος! Τραυματισμοί από κοπή ▶ Φοράτε προστατευτικά γάντια. |
|--|--|

Προϋπόθεση:

- ✓ Η συσκευή είναι αποσυνδεδεμένη από την παροχή τροφοδοσίας.
- ✓ Η συσκευή είναι αποσυνδεδεμένη από την παροχή νερού.
- ✓ Η πρόσβαση στις συσκευές είναι ελεύθερη.
- ✓ Έχει αφαιρεθεί το συρτάρι απορρυπαντικού.→219
- ✓ Έχει αφαιρεθεί η πρόσοψη του ντουλαπιού.
- ✓ Η πόρτα έχει αφαιρεθεί.→221
- ✓ Έχει αφαιρεθεί το στεγανοποιητικό πόρτας.

4.11.1 Αφαίρεση μπροστινού πίνακα

1. Λύστε τον συγκρατητή του φωτισμού τυμπάνου.

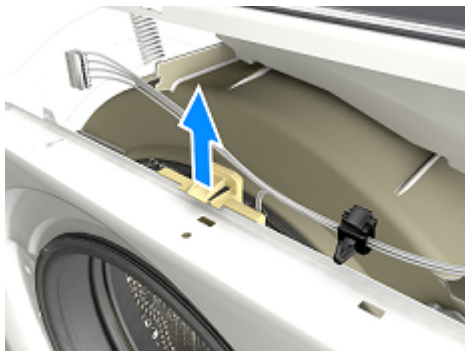

2.

| | |
|---|---|
|  | ΠΡΟΣΟΧΗ Κίνδυνοι από πτώση μερών εξαιτίας χαλαρών βιδών! Τραυματισμός εξαιτίας πτώσης τμημάτων. ▶ Ασφαλίστε τα εξαρτήματα από πτώση. |
|---|---|

| | |
|---|---|
|  | ΠΡΟΣΟΧΗ! Κίνδυνων από πτώση εξαρτημάτων εξαιτίας χαλαρών βιδών! Ζημιά σε άλλα μέρη της συσκευής ή στην οικία του πελάτη, π.χ. δάπεδο. ▶ Ασφαλίστε τα εξαρτήματα από πτώση. |
|---|---|

Λύστε τις βίδες με την υποδεικνυόμενη σειρά.







3. Αφαιρέστε το μπροστινό πλαίσιο.

4.11.2 Τοποθέτηση μπροστινού πίνακα

▶ Εγκαταστήστε με την αντίθετη σειρά.

Javítási útmutató - Mosógép

| | |
|--|------------|
|  A dokumentummal kapcsolatos információk..... | 234 |
| 1.1 Fontos tudnivalók | 234 |
| 1.1.1 Cél | 234 |
| 1.2 Szimbólummagyarázat | 234 |
| 1.2.1 Veszélyességi szintek | 234 |
| 1.2.2 Veszélyt jelző szimbólumok | 234 |
| 1.2.3 A figyelmeztetések felépítése | 235 |
| 1.2.4 Általános szimbólumok..... | 235 |
|  Biztonság | 236 |
| 2.1 Általános biztonsági utasítások..... | 236 |
| 2.1.1 Összes háztartási készülék | 236 |
|  Szerszámok és segédanyagok..... | 237 |
|  Javítás | 238 |
| 4.1 A vezérlőpanel cseréje..... | 238 |
| 4.1.1 A vezérlőpanel eltávolítása | 238 |
| 4.1.2 A vezérlőpanel telepítése | 239 |
| 4.2 A mosószer-adagoló cseréje | 240 |
| 4.2.1 A mosószer-adagoló eltávolítása | 240 |
| 4.2.2 A mosószer-adagoló behelyezése..... | 240 |
| 4.3 A mosószer-adagoló fogantyújának cseréje | 241 |
| 4.3.1 A mosószer-adagoló fogantyújának eltávolítása..... | 241 |
| 4.3.2 A mosószer-adagoló fogantyújának behelyezése..... | 241 |
| 4.4 Az ajtó cseréje..... | 242 |
| 4.4.1 Az ajtó eltávolítása | 242 |
| 4.4.2 Az ajtó felhelyezése | 242 |
| 4.5 Az ajtó alkatrészeinek cseréje | 243 |
| 4.5.1 Az ajtó alkatrészeinek eltávolítása..... | 243 |
| 4.5.2 Az ajtó alkatrészeinek felhelyezése | 243 |
| 4.6 Az ajtózsánér cseréje | 244 |
| 4.6.1 Az ajtózsánér eltávolítása | 244 |
| 4.6.2 Az ajtózsánér felhelyezése | 244 |
| 4.7 A gumitömítés cseréje | 245 |
| 4.7.1 A gumitömítés eltávolítása..... | 245 |
| 4.7.2 Gumitömítés felhelyezése | 246 |

| | |
|--|-----|
| 4.8 Ajtózár cseréje | 247 |
| 4.8.1 Az ajtózár eltávolítása | 247 |
| 4.8.2 Az ajtózár behelyezése | 248 |
| 4.9 A belső dobvilágítás cseréje | 249 |
| 4.9.1 A belső dobvilágítás eltávolítása..... | 249 |
| 4.9.2 A belső dobvilágítás telepítése | 249 |
| 4.10 Az alsó burkolat cseréje | 250 |
| 4.10.1 Alsó burkolat eltávolítása | 250 |
| 4.10.2 A burkolat telepítése | 251 |
| 4.11 Az elülső panel cseréje..... | 252 |
| 4.11.1 Az elülső panel eltávolítása | 252 |
| 4.11.2 Az elülső panel telepítése | 253 |

i A dokumentummal kapcsolatos információk

1.1 Fontos tudnivalók

1.1.1 Cél

Ezek a javítási tanácsok támogatják a fogyasztót a készülékek otthoni megjavításában a környezettudatos tervezésről szóló rendeletnek (2021 márciusától alkalmazandó) megfelelően.





Információkat tartalmaznak bizonyos pótalkatrészek cseréjével kapcsolatban, ideértve a figyelmeztetéseket és a kockázatokat is.

Ha kérdése van, vegye fel a kapcsolatot a vevőszolgálattal. A károkért kizárólag akkor vállalunk felelősséget, ha a javítási tanácsokat pontosan betartották.

1.2 Szimbólummagyarázat

1.2.1 Veszélyességi szintek

A veszélyességi szintek egy szimbólumból és egy figyelmeztető mondatból állnak. A figyelmeztető mondat utal a veszély súlyosságára.





| Veszélyességi szint | Jelentés |
|---|--|
|  VESZÉLY | A figyelmeztető üzenet figyelmen kívül hagyása halált vagy súlyos sérüléseket okoz. |
|  FIGYELMEZTETÉS | A figyelmeztető üzenet figyelmen kívül hagyása halált vagy súlyos sérüléseket okozhat. |
|  VIGYÁZAT | A figyelmeztető üzenet figyelmen kívül hagyása kisebb sérüléseket okozhat. |
|  FIGYELEM! | A figyelmeztető üzenet figyelmen kívül hagyása anyagi károkat okozhat. |

Táblázat 1: Veszélyességi szintek

1.2.2 Veszélyt jelző szimbólumok

A veszélyt jelző szimbólumok a veszélyt ábrázoló szimbolikus ábrázolások.

A jelen dokumentumban az alábbi veszélyt jelző szimbólumok használatosak:

| Veszélyt jelző szimbólum | Jelentés |
|---|--------------------------------|
|  | Általános figyelmeztető üzenet |
|  | Elektromos feszültség veszélye |
|  | Robbanásveszély |
|  | Vágásveszély |
|  | Zúzódásveszély |

i A dokumentummal kapcsolatos információk

| Veszélyt jelző szimbólum | Jelentés |
|--------------------------|---|
| | Forró felületek miatt fennálló veszély |
| | Erős mágneses mező miatt fennálló veszély |
| | Nem ionizáló sugárzás veszélye |

Táblázat 2: Veszélyt jelző szimbólumok

1.2.3 A figyelmeztetések felépítése

A jelen dokumentumban lévő figyelmeztetések szabványosított megjelenésűek és felépítésűek.

| | |
|--|---|
| | <p>⚠ VESZÉLY</p> <p>A veszély típusa és forrása! A veszély / figyelmeztetés figyelmen kívül hagyásának lehetséges következményei.</p> <ul style="list-style-type: none"> ▶ A veszély megelőzésére szolgáló intézkedések és tiltások. |
|--|---|

Az alábbi példa egy olyan figyelmeztetést mutat be, amely az áram alatt lévő alkatrészek okozta áramütésre figyelmeztet. Megemlíti a veszély elkerülésére szolgáló intézkedést.

| | |
|--|--|
| | <p>⚠ VESZÉLY</p> <p>Áramütés veszélye áram alatt lévő alkatrészek miatt! Halálos áramütés</p> <ul style="list-style-type: none"> ▶ A javítás megkezdése előtt legalább 60 másodperccel válassza le a készülékeket az elektromos hálózatról. |
|--|--|

1.2.4 Általános szimbólumok

A jelen dokumentumban az alábbi általános szimbólumok használatosak:

| Ált. szimbólum | Jelentés |
|----------------|--|
| | Különleges tanács (szöveg és/vagy grafika) |

| Ált. szimbólum | Jelentés |
|----------------|--|
| | Egyszerű tanács (csak szöveg) |
| | Videós oktatóanyagra mutató hivatkozás |
| | A szükséges eszközök |
| | A szükséges feltételek |
| | Feltétel (ha..., akkor...) |
| | Eredmény |
| [Indítás] | Billentyű vagy gomb |
| [00123456] | Anyagszám azonosítója |
| Állapot | Megjelenített szöveg / ablak (a készülék kijelzőjén) |

Táblázat 3: Általános szimbólumok

2.1 Általános biztonsági utasítások

2.1.1 Összes háztartási készülék

Áramütés veszélye áram alatt lévő alkatrészek miatt!

- Az elektromos alkatrészek hibás javítása áramütéshez vezethet!
- A javítás megkezdése előtt legalább 60 másodperccel válassza le a készüléket az elektromos hálózatról.
- A javítás után végeztesse a VDE 0701-nek vagy az országspecifikus szabályozásoknak megfelelő vizsgálatot.

Éles peremek miatt fennálló sérülésveszély!

- Viseljen védőkesztyűt.

Zúzódásveszély a javítás, karbantartás, hibaelhárítás és szervizelés során a nehéz és mozgó alkatrészek miatt

- Viseljen védőcipőt.
- Biztosítsa leesés ellen a nehéz alkatrészeket.
- Ne dugja be a testrészeit a mozgó alkatrészek közé.







Sérülhet a készülék biztonsága / működése!



- Kizárólag eredeti pótalkatrészeket használjon.

Elektrosztatikailag érzékeny alkatrészek (ESD-k) károsodásának veszélye!





- Ne érintse meg a modulokat, ideértve a csatlakozásokat és a vezetőket.

Szerszámok és segédanyagok

| Kijelölés | Részletek | Képek |
|--|--|---|
| Segédeszköz [15000155] | Műanyag alkatrészek meglazítására szolgáló szerszám |  |
| Biztonsági Torx T20 csavarhúzó [00340764] | 100°mm, biztonsági csavarokhoz |  |
| Nyomatékkulcs [15000441] | Nyomatékkulcs 20–100 Nm | |
| Lapos csavarhúzó [00340854] | Fej: 3,5 mm x 0,6 mm x 100 mm, Szigetelés: 1000 V AC |  |
| Lapos csavarhúzó [00340855] | Fej: 5,5 mm x 1,0 mm x 125 mm, Szigetelés: 1000 V AC |  |
| Hosszúcsőrű fogó, hajlított kialakítás [00341269] | Hossz: 200 mm |  |
| Oldalcsípő fogó [00342182] | Hossz: 200 mm |  |
| Csillag-Villáskulcs [00340811] | Méret 10°mm, M6 |  |

| Kijelölés | Részletek | Képek |
|-----------------------------------|------------------|---|
| Combination wrench [00340814] | Méret 13°mm, M8 |  |
| Csillag-Villáskulcs [00340817] | Méret 17 mm, M10 |  |
| Csillag-Villáskulcs [15000459] | Méret 16°mm, M10 |  |

4.1 A vezérlőpanel cseréje

| | |
|--|---|
|  | VIGYÁZAT Éles burkolatszélek! Vágási sérülések ▶ Viseljen védőkesztyűt. |
|  | FIGYELMEZTETÉS Megdöntött készülékek elcsúszása! Csonttörés / zúzódási sérülések ▶ Biztosítsa a készülékeket elcsúszás ellen. |
|  | VIGYÁZAT Leeső alkatrészek veszélye a kioldott csavarok miatt! Leeső alkatrészek miatti sérülés. ▶ Biztosítsa az alkatrészt leesés ellen. |
|  | FIGYELEM! Leeső alkatrészek veszélye a kioldott csavarok miatt! A készülék többi részeinek vagy az ügyfél lakásának (pl. padló) károsodása. ▶ Biztosítsa az alkatrészt leesés ellen. |

Követelmény:

- ✓ A készüléket leválasztotta az áramellátásról.
- ✓ A készüléket leválasztotta a vízellátásról.
- ✓ A készülékek szabadon hozzáférhetők.
- ✓ [Eltávolította a mosószer-adagolót.→240](#)

4.1.1 A vezérlőpanel eltávolítása

1. Lazítsa meg a rögzítőelemet (1).
2. Távolítsa el a fedelet (2).

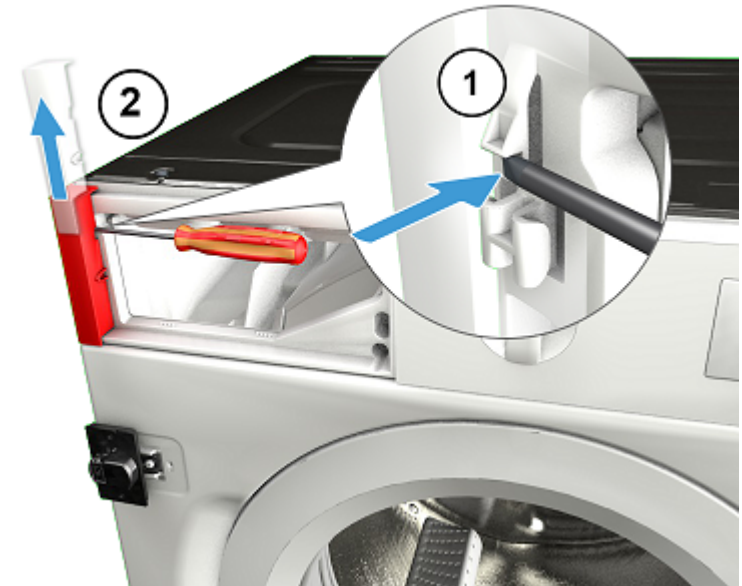

2. Távolítsa el a csavarokat.



3. 1. Lazítsa meg a rögzítőelemeket (1, 2).
2. Húzza a vezérlőpanelt előre (3).

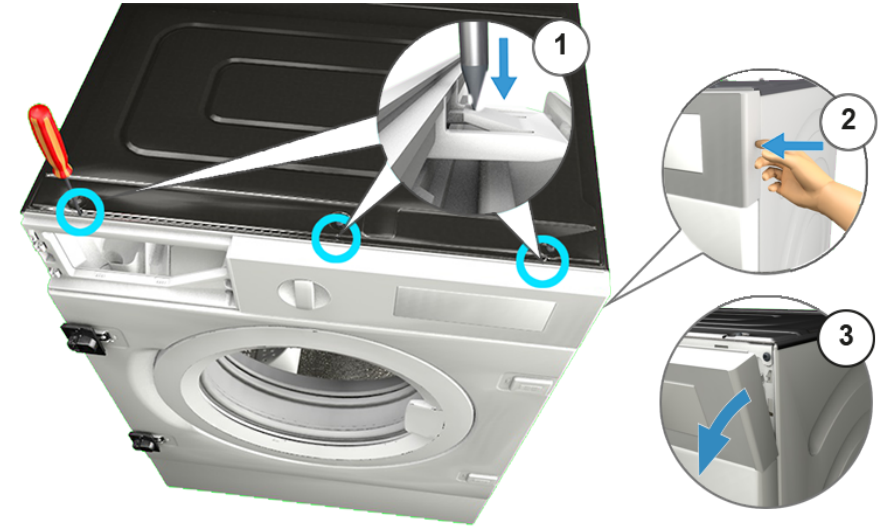

4. Távolítsa el a vezérlőpanelt.

4.1.2 A vezérlőpanel telepítése

- Az elhelyezést fordított sorrendben végezze.

4.2 A mosószer-adagoló cseréje

Követelmény:

- ✔ A készüléket leválasztotta az áramellátásról.
- ✔ A készüléket leválasztotta a vízellátásról.

4.2.1 A mosószer-adagoló eltávolítása

1. Húzza ki a mosószer-adagoló rekeszt.
2. 1. Nyomja le a fiókot (1).
2. Távolítsa el a mosószer-adagoló rekeszt (2).

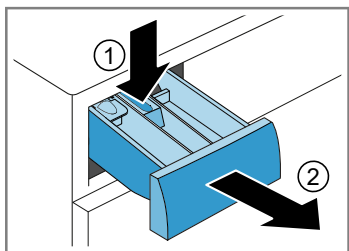

4.2.2 A mosószer-adagoló behelyezése

- ▶ Az elhelyezést fordított sorrendben végezze.

4.3 A mosószer-adagoló fogantyújának cseréje

Követelmény:

- ✔ A készüléket leválasztotta az áramellátásról.
- ✔ A készüléket leválasztotta a vízellátásról.
- ✔ [Eltávolította a mosószer-adagolót.→240](#)

4.3.1 A mosószer-adagoló fogantyújának eltávolítása

1. Lazítsa meg a rögzítőelemeket.

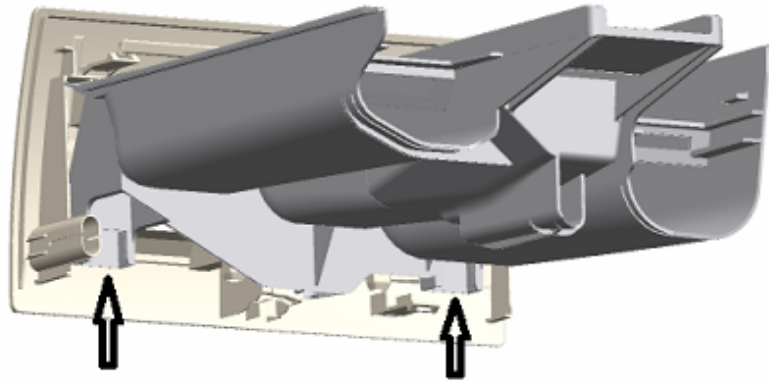

2. Távolítsa el a mosószer-adagoló rekesz fogantyúját.

4.3.2 A mosószer-adagoló fogantyújának behelyezése

- ▶ Az elhelyezést fordított sorrendben végezze.

4.4 Az ajtó cseréje



VIGYÁZAT

Nyitott zsanér!

Ujjak zúzódása/beszorulása

- ▶ Ne nyúljon be a nyitott zsanérba.
- ▶ Viseljen védőkesztyűt.

Követelmény:

- ✔ A készüléket leválasztotta az áramellátásról.
- ✔ A készüléket leválasztotta a vízellátásról.
- ✔ Az ajtó nyitva van.
- ✔ A bútorlapot eltávolították.

4.4.1 Az ajtó eltávolítása

1.



FIGYELEM!

Leeső alkatrészek veszélye a kioldott csavarok miatt!

A készülék többi részeinek vagy az ügyfél lakásának (pl. padló) károsodása.

- ▶ Biztosítsa az alkatrészt leesés ellen.



VIGYÁZAT

Leeső alkatrészek veszélye a kioldott csavarok miatt!

Leeső alkatrészek miatti sérülés.

- ▶ Biztosítsa az alkatrészt leesés ellen.

Távolítsa el a csavarokat (1).

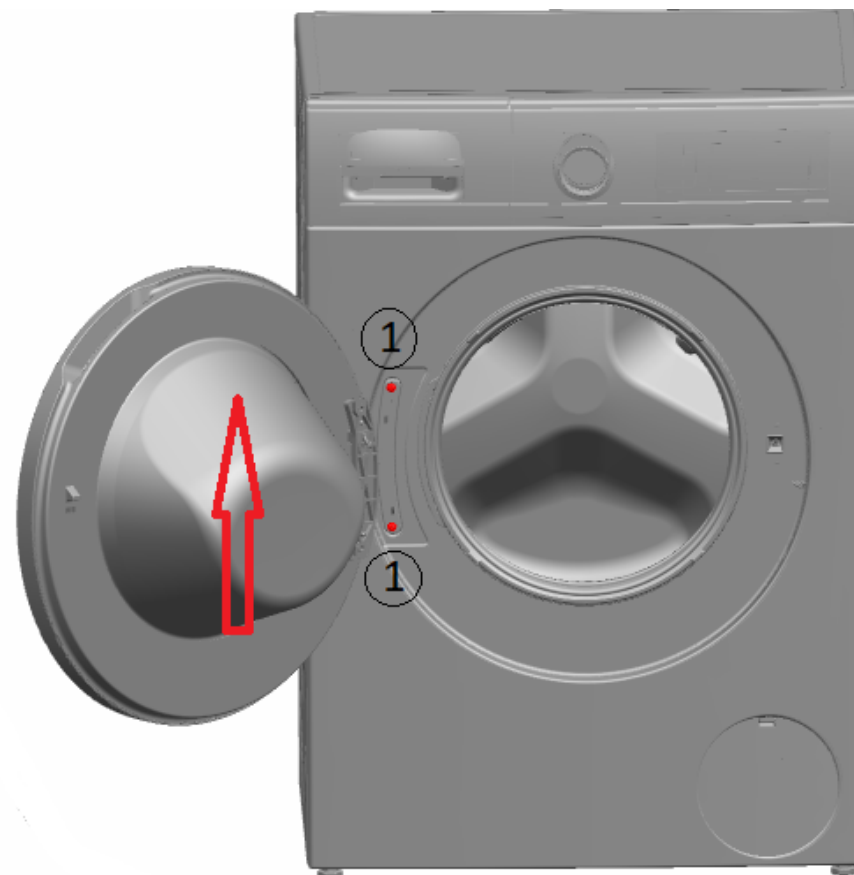

2. Felfelé húzva távolítsa el az ajtót.

4.4.2 Az ajtó felhelyezése

- ▶ Az elhelyezést fordított sorrendben végezze.

4.5 Az ajtó alkatrészeinek cseréje



VIGYÁZAT

Nyitott zsanér!

Ujjak zúzódása/beszorulása

- ▶ Ne nyúljon be a nyitott zsanérba.
- ▶ Viseljen védőkesztyűt.

Követelmény:

- ✓ A készüléket leválasztotta az áramellátásról.
- ✓ A készüléket leválasztotta a vízellátásról.
- ✓ A bútorlapot eltávolították.
- ✓ [Eltávolította az ajtót. → 242](#)

4.5.1 Az ajtó alkatrészeinek eltávolítása

- ▶ Kívülről befelé haladva szerelje szét az ajtót.

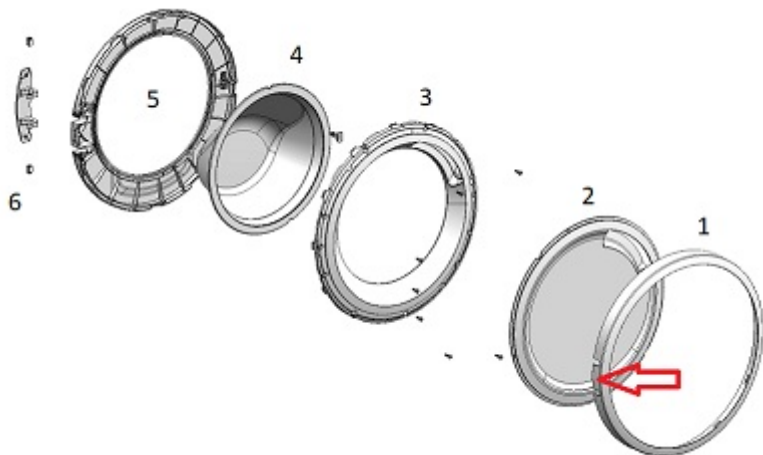

4.5.2 Az ajtó alkatrészeinek felhelyezése

- ▶ Az elhelyezést fordított sorrendben végezze.

4.6 Az ajtózsánér cseréje

| | |
|--|---|
|  | ⚠ VIGYÁZAT |
| | Nyitott zsanér! Ujjak zúzódása/beszorulása <ul style="list-style-type: none">▶ Ne nyúljon be a nyitott zsanérba.▶ Viseljen védőkesztyűt. |

Követelmény:

- ✔ A készüléket leválasztotta az áramellátásról.
- ✔ A készüléket leválasztotta a vízellátásról.

4.6.1 Az ajtózsánér eltávolítása

1. Lazítsa meg a két csavart.
2. Vegye le az ajtót.
3. Kívülről befelé haladva szerelje szét az ajtót.

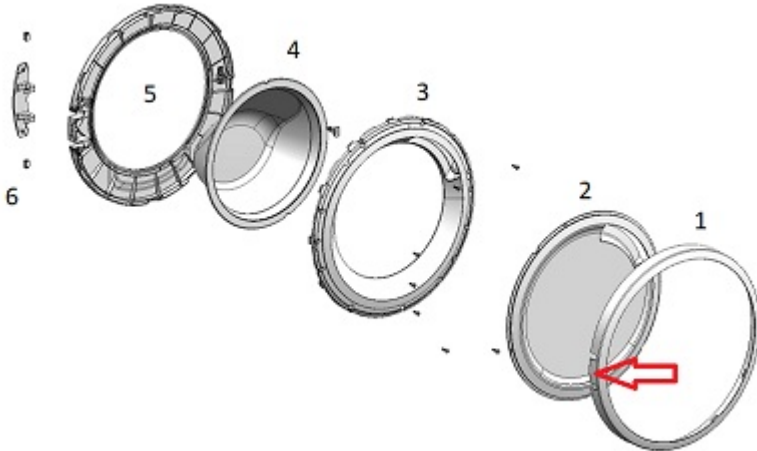



4. Távolítsa el az ajtózsánért.

4.6.2 Az ajtózsánér felhelyezése

- ▶ Az elhelyezést fordított sorrendben végezze.

4.7 A gumitömítés cseréje

| | |
|--|---|
|  | <p style="text-align: center;">⚠ VIGYÁZAT</p> <p>Éles burkolatszélek! Vágási sérülések</p> <ul style="list-style-type: none"> ▶ Viseljen védőkesztyűt. |
|--|---|

| | |
|--|---|
|  | <p style="text-align: center;">⚠ VIGYÁZAT</p> <p>Leeső alkatrészek veszélye a kioldott csavarok miatt! Leeső alkatrészek miatti sérülés.</p> <ul style="list-style-type: none"> ▶ Biztosítsa az alkatrészt leesés ellen. |
|--|---|

| | |
|--|--|
|  | <p style="text-align: center;">FIGYELEM!</p> <p>Leeső alkatrészek veszélye a kioldott csavarok miatt! A készülék többi részeinek vagy az ügyfél lakásának (pl. padló) károsodása.</p> <ul style="list-style-type: none"> ▶ Biztosítsa az alkatrészt leesés ellen. |
|--|--|

Követelmény:

- ✓ A készüléket leválasztotta az áramellátásról.
- ✓ A készüléket leválasztotta a vízellátásról.
- ✓ A készülékek szabadon hozzáférhetők.
- ✓ [Eltávolította a mosószer-adagolót.→240](#)
- ✓ A vezérlőpanelt eltávolították.
- ✓ [Eltávolította az ajtót.→242](#)
- ✓ [Az alsó burkolatot eltávolították.→250](#)

4.7.1 A gumitömítés eltávolítása

1. Távolítsa el a belső dobvilágítás rögzítőjét.



2.

| | |
|---|--|
|  | <p style="text-align: center;">FIGYELEM!</p> <p>Sérült felület kockázata! A helytelen szerszámok használatával megkarcolhatja a készülék felületét.</p> <ul style="list-style-type: none"> ▶ A fesztítőgyűrű eltávolításához kizárólag műanyag szerszámokat használjon. |
|---|--|

Távolítsa el a fesztítőgyűrűt a tömítésből egy műanyag szerszámmal.

3. Vegye ki a tömítést az elülső panelből.
4. Vegye ki a kábelcsatlakozót az ajtózárból.

5. Lazítsa meg a csavarokat a megadott sorrendben.



6. Távolítsa el az előlső panelt.

7. Válassza le a tömlőcsatlakozásokat.

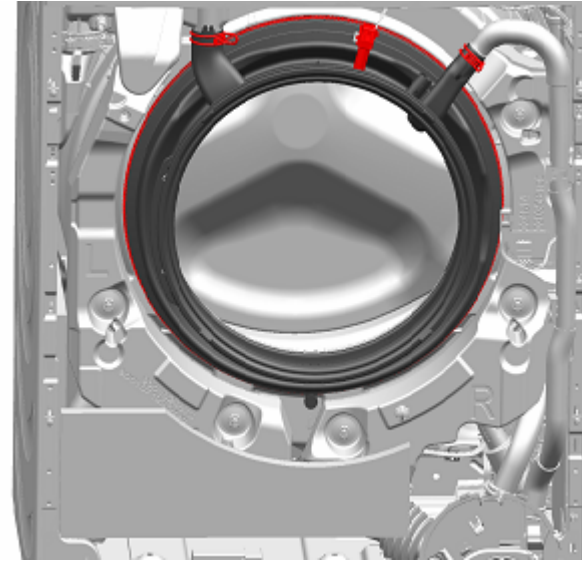

8. Távolítsa el a gumitömítést.

4.7.2 Gumitömítés felhelyezése

- ▶ Az elhelyezést fordított sorrendben végezze.

4.8 Ajtózár cseréje

Gyártóként kötelességünk tartalék alkatrészként ajtózárat biztosítani a vásárlók számára, beleértve a javítási utasításokat is a 2019/2023 EU-rendeletnek megfelelően. Felhívjuk a figyelmét, hogy az ajtózár cseréje után egy képzett elektroműszerésznek elektrotechnikai biztonsági vizsgálatot kell végeznie a készülék üzembe helyezése előtt. A vizsgálatot végző személynek az adott ország törvényei, szabályozásai és szabványai szerint meghatározott képesítéssel kell rendelkeznie.

| | |
|--|---|
|  | ⚠ VESZÉLY Áramütés veszélye áram alatt lévő alkatrészek miatt! Életveszély a nem megfelelő javítás okozta áramütés miatt <ul style="list-style-type: none">▶ Az elektromos alkatrészek javítását kizárólag képzett elektroműszerész végezheti.▶ A javítás után végeztessen a VDE 0701-nek vagy az országspecifikus szabályozásoknak megfelelő vizsgálatot. |
|  | ⚠ VIGYÁZAT Éles burkolatszélék! Vágási sérülések <ul style="list-style-type: none">▶ Viseljen védőkesztyűt. |
|  | ⚠ FIGYELMEZTETÉS Megdöntött készülékek elcsúszása! Csonttörés / zúzódási sérülések <ul style="list-style-type: none">▶ Biztosítsa a készülékeket elcsúszás ellen. |
|  | ⚠ VIGYÁZAT Leeső alkatrészek veszélye a kioldott csavarok miatt! Leeső alkatrészek miatti sérülés. <ul style="list-style-type: none">▶ Biztosítsa az alkatrészt leesés ellen. |
|  | FIGYELEM! Leeső alkatrészek veszélye a kioldott csavarok miatt! A készülék többi részeinek vagy az ügyfél lakásának (pl. padló) károsodása. <ul style="list-style-type: none">▶ Biztosítsa az alkatrészt leesés ellen. |

Követelmény:

- ✓ A készüléket leválasztotta az áramellátásról.

- ✓ A készüléket leválasztotta a vízellátásról.
- ✓ A készülékek szabadon hozzáférhetők.
- ✓ A bútorlapot eltávolították.
- ✓ A vezérlőpanelt eltávolították.
- ✓ [Eltávolította az ajtót. → 242](#)
- ✓ A feszítőgyűrűt eltávolították.
- ✓ Az elülső panelt eltávolították.
- ✓ A gumitömítést eltávolították.

4.8.1 Az ajtózár eltávolítása

1. Válassza le az ajtózár csatlakozóját.
2. Lazítsa meg az ajtózárat.



3. Vegye ki az ajtózárat.

4.8.2 Az ajtózár behelyezése

Az ajtózárnak megfelelő pozícióban kell lennie ahhoz, hogy a vészhelyzeti ajtónyitás működőképes legyen.

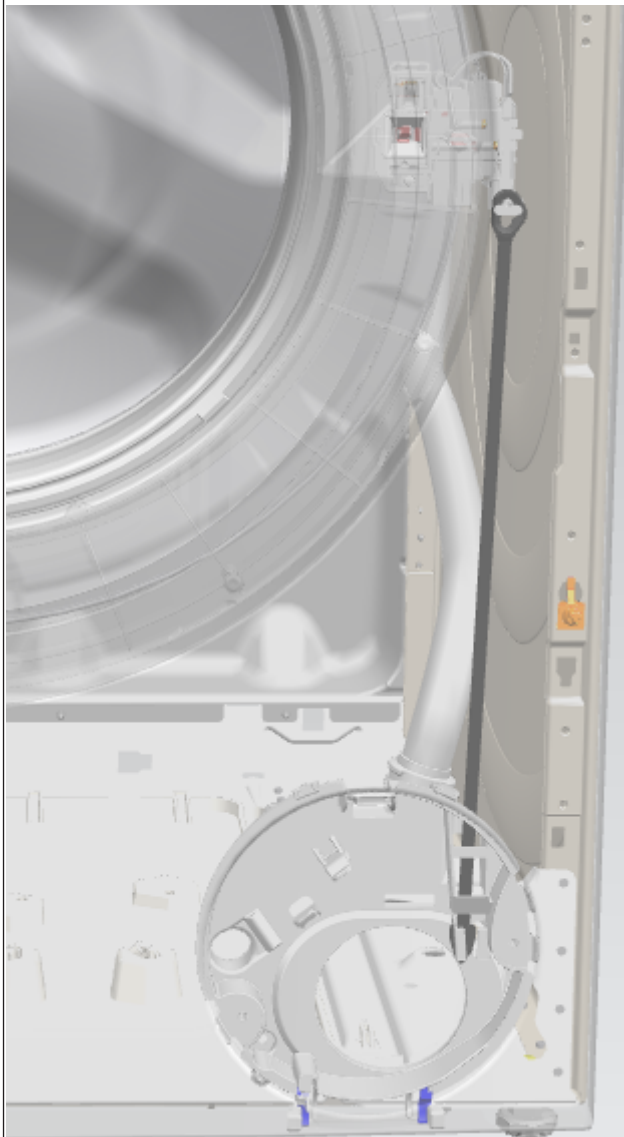

- ▶ Az elhelyezést fordított sorrendben végezze.

4.9 A belső dobvilágítás cseréje



VIGYÁZAT

Éles burkolatszélek!

Vágási sérülések

- ▶ Viseljen védőkesztyűt.



FIGYELMEZTETÉS

Megdöntött készülékek elcsúszása!

Csonttörés / zúzódási sérülések

- ▶ Biztosítsa a készülékeket elcsúszás ellen.



VIGYÁZAT

Leeső alkatrészek veszélye a kioldott csavarok miatt!

Leeső alkatrészek miatti sérülés.

- ▶ Biztosítsa az alkatrészt leesés ellen.



FIGYELEM!

Leeső alkatrészek veszélye a kioldott csavarok miatt!

A készülék többi részeinek vagy az ügyfél lakásának (pl. padló) károsodása.

- ▶ Biztosítsa az alkatrészt leesés ellen.

Követelmény:

- ✓ A készüléket leválasztotta az áramellátásról.
- ✓ A készüléket leválasztotta a vízellátásról.
- ✓ A készülékek szabadon hozzáférhetők.
- ✓ [Eltávolította a mosószer-adagolót.→240](#)
- ✓ A vezérlőpanelt eltávolították.

4.9.1 A belső dobvilágítás eltávolítása

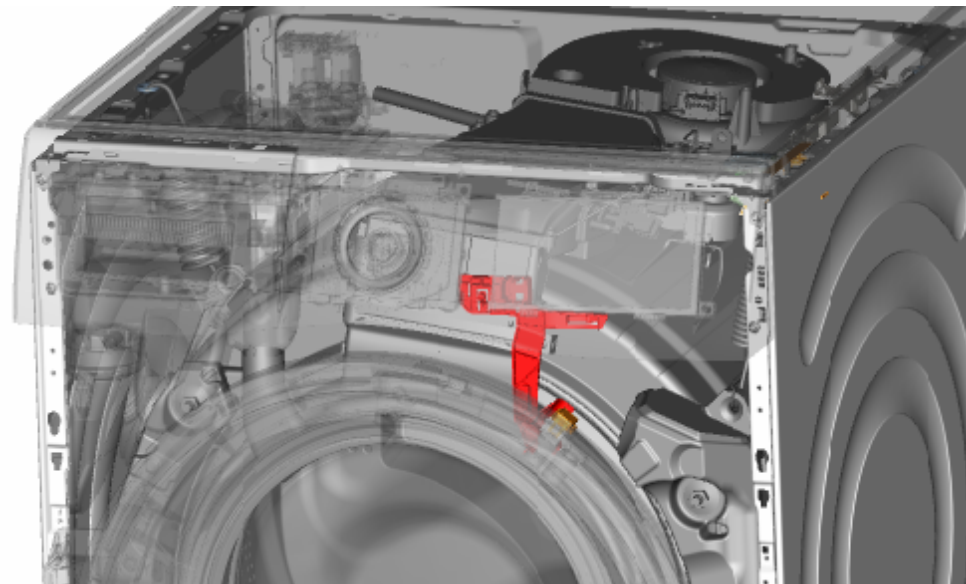

1. Húzza ki a belső dobvilágítás tartóját a készülékből.
2. Válassza le az elektromos csatlakozókat.
3. Távolítsa el a belső dobvilágítást a belső dobvilágítás tartójából.

4.9.2 A belső dobvilágítás telepítése

- ▶ Az elhelyezést fordított sorrendben végezze.

4.10 Az alsó burkolat cseréje



Ábra 1: Alsó rész burkolata

Követelmény:

- ✔ A készüléket leválasztotta az áramellátásról.
- ✔ A készüléket leválasztotta a vízellátásról.
- ✔ A bútorlapot eltávolították.

4.10.1 Alsó burkolat eltávolítása

Követelmény:

- ✔ A készüléket leválasztotta az áramellátásról.
- ✔ A készüléket leválasztotta a vízellátásról.

1. Távolítsa el az alsó burkolatot.

2. Válassza le a tömlőt a tartóról.

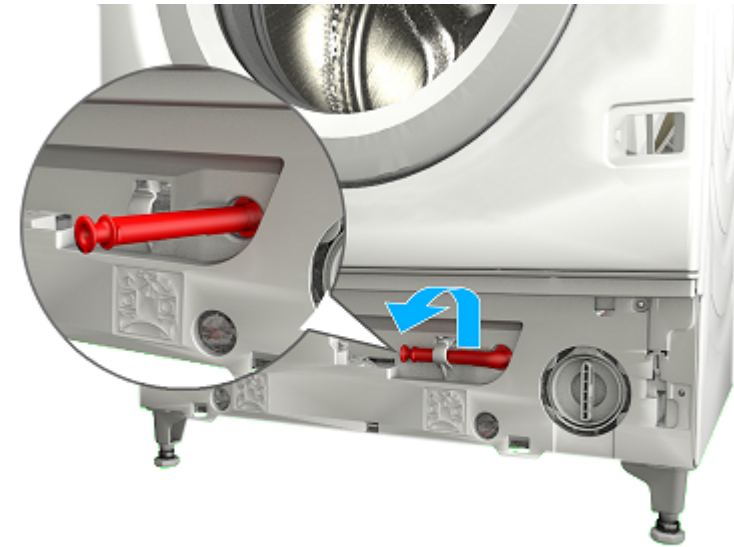

3. 1. Csavarja ki a csavart (1).
2. Nyomja meg a rögzítőpontot, és lefelé irányban távolítsa el (2).

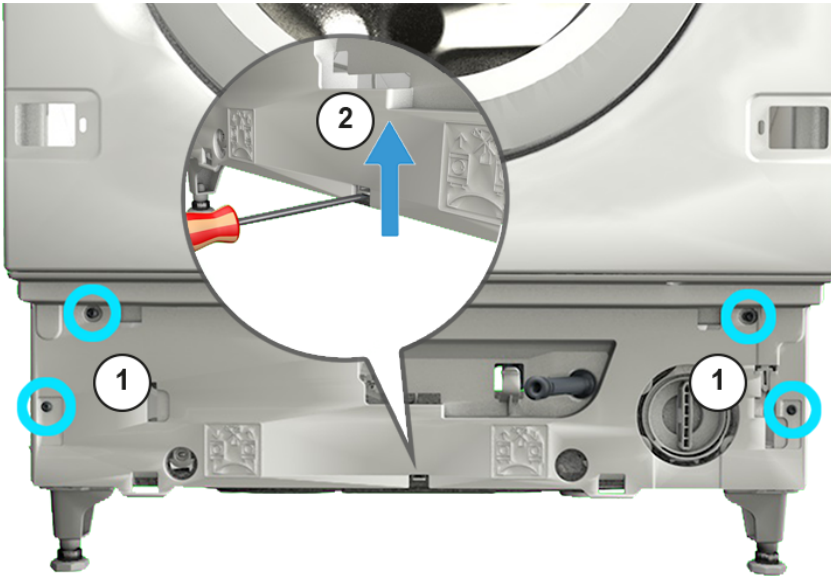

4. Húzza meg az alsó rész burkolatát, és előrefelé távolítsa el.

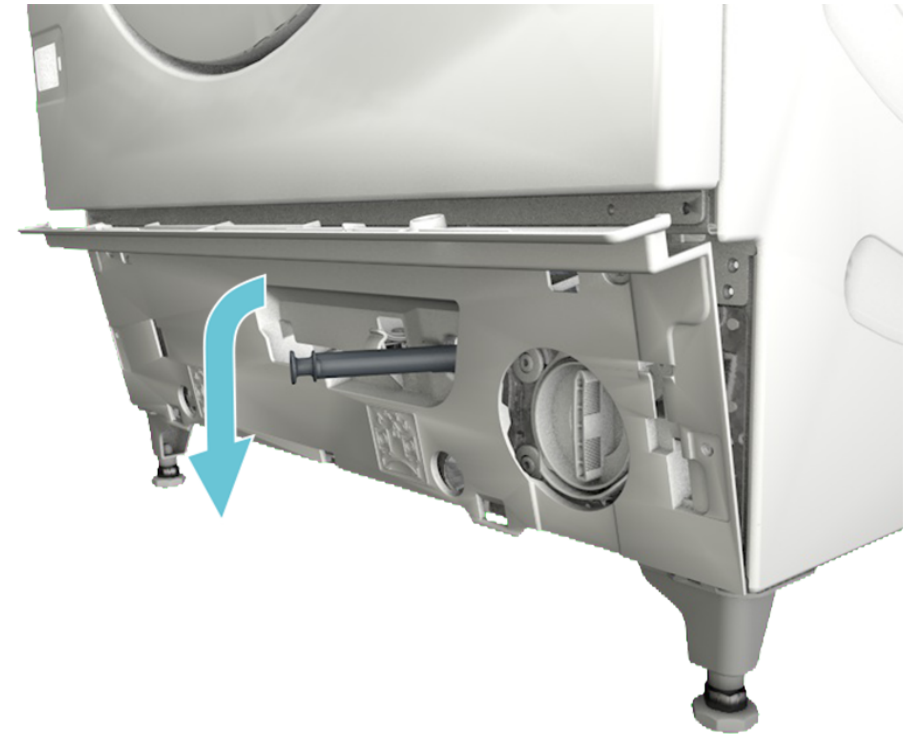

5. Húzza ki a tömlőt a burkolatból.

4.10.2 A burkolat telepítése

- ▶ Az elhelyezést fordított sorrendben végezze.

4.11 Az elülső panel cseréje

| | |
|--|---|
|  | VIGYÁZAT Éles burkolatszélék! Vágási sérülések ▶ Viseljen védőkesztyűt. |
|--|---|

Követelmény:

- ✓ A készüléket leválasztotta az áramellátásról.
- ✓ A készüléket leválasztotta a vízellátásról.
- ✓ A készülékek szabadon hozzáférhetők.
- ✓ [Eltávolította a mosószer-adagolót.→240](#)
- ✓ A bútorlapot eltávolították.
- ✓ [Eltávolította az ajtót.→242](#)
- ✓ A gumitömítést eltávolították.

4.11.1 Az elülső panel eltávolítása

1. Távolítsa el a belső dobvilágítás rögzítőjét.

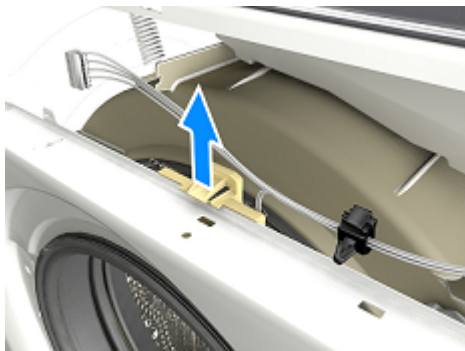

2.

| | |
|---|---|
|  | VIGYÁZAT Leeső alkatrészek veszélye a kioldott csavarok miatt! Leeső alkatrészek miatti sérülés. ▶ Biztosítsa az alkatrészt leesés ellen. |
|---|---|

| | |
|---|--|
|  | FIGYELEM! Leeső alkatrészek veszélye a kioldott csavarok miatt! A készülék többi részeinek vagy az ügyfél lakásának (pl. padló) károsodása. ▶ Biztosítsa az alkatrészt leesés ellen. |
|---|--|

Lazítsa meg a csavarokat a megadott sorrendben.



3. Távolítsa el az elülső panelt.

4.11.2 Az elülső panel telepítése

▶ Az elhelyezést fordított sorrendben végezze.

Consigli di riparazione - Lavatrice

Utilizzo del documento 255

| | | |
|-------|------------------------------|-----|
| 1.1 | Avvertenze importanti | 255 |
| 1.1.1 | Scopo | 255 |
| 1.2 | Spiegazione dei simboli | 255 |
| 1.2.1 | Livelli di pericolo | 255 |
| 1.2.2 | Simboli di pericolo | 255 |
| 1.2.3 | Struttura degli avvertimenti | 256 |
| 1.2.4 | Simboli generici | 256 |

Sicurezza 257

| | | |
|-------|-------------------------------|-----|
| 2.1 | Note generali sulla sicurezza | 257 |
| 2.1.1 | Tutti gli elettrodomestici | 257 |

Strumenti e ausili 258

Riparazione..... 259

| | | |
|-------|--|-----|
| 4.1 | Sostituzione del pannello comandi | 259 |
| 4.1.1 | Smontaggio del pannello comandi | 259 |
| 4.1.2 | Montaggio del pannello comandi | 260 |
| 4.2 | Sostituzione del cassetto del detersivo | 261 |
| 4.2.1 | Smontaggio del cassetto del detersivo | 261 |
| 4.2.2 | Montaggio del cassetto del detersivo | 261 |
| 4.3 | Sostituzione della maniglia del cassetto del detersivo | 262 |
| 4.3.1 | Smontaggio della maniglia del cassetto del detersivo | 262 |
| 4.3.2 | Montaggio della maniglia del cassetto del detersivo | 262 |
| 4.4 | Sostituzione dell'oblò | 263 |
| 4.4.1 | Smontaggio dell'oblò | 263 |
| 4.4.2 | Montaggio dell'oblò | 263 |
| 4.5 | Sostituzione dei componenti dell'oblò | 264 |
| 4.5.1 | Smontaggio dei componenti dell'oblò | 264 |
| 4.5.2 | Montaggio dei componenti dell'oblò | 264 |
| 4.6 | Sostituzione della cerniera dell'oblò | 265 |
| 4.6.1 | Rimozione della cerniera dell'oblò | 265 |
| 4.6.2 | Montaggio della cerniera dell'oblò | 265 |
| 4.7 | Sostituzione della guarnizione dell'oblò | 266 |
| 4.7.1 | Rimozione della guarnizione dell'oblò | 266 |
| 4.7.2 | Installazione della guarnizione dell'oblò | 267 |

| | | |
|--------|--|-----|
| 4.8 | Sostituzione del blocco porta | 268 |
| 4.8.1 | Smontaggio del blocco porta | 268 |
| 4.8.2 | Montaggio del blocco porta | 269 |
| 4.9 | Sostituzione della luce del cestello | 270 |
| 4.9.1 | Smontaggio della luce del cestello | 270 |
| 4.9.2 | Montaggio della luce del cestello | 270 |
| 4.10 | Sostituzione della copertura inferiore | 271 |
| 4.10.1 | Smontaggio della copertura inferiore | 271 |
| 4.10.2 | Montaggio della copertura | 272 |
| 4.11 | Sostituzione del pannello frontale | 273 |
| 4.11.1 | Smontaggio del pannello frontale | 273 |
| 4.11.2 | Montaggio del pannello frontale | 274 |

i Utilizzo del documento

1.1 Avvertenze importanti

1.1.1 Scopo

Queste istruzioni di riparazione spiegano ai clienti come riparare da soli gli elettrodomestici in conformità alle regole sull'Ecodesign vigenti (al 03/2021).

Contengono informazioni sulla sostituzione di pezzi di ricambio specifici e sulle avvertenze e i rischi correlati.

In caso di domande, contattare l'assistenza tecnica. Il mancato rispetto di tali istruzioni da parte dei clienti ci esonera da qualsiasi responsabilità.

1.2 Spiegazione dei simboli

1.2.1 Livelli di pericolo

I livelli di avvertimento corrispondono a un simbolo accompagnato da una parola di allerta. La parola di allerta identifica il livello di pericolo.





| Livello di avvertimento | Significato |
|--|---|
|  PERICOLO | Ignorare questo messaggio di avvertimento comporta rischio di morte o ferite gravi. |
|  AVVERTENZA | Ignorare questo messaggio di avvertimento può comportare rischio di morte o ferite gravi. |
|  ATTENZIONE | Ignorare questo messaggio di avvertimento può comportare ferite di minore gravità. |
|  ATTENZIONE! | Ignorare questo messaggio di avvertimento può comportare danni materiali. |

Tabella 1: Livelli di pericolo

1.2.2 Simboli di pericolo

I simboli di pericolo sono illustrazioni che specificano la tipologia di rischio.

Nella presente documentazione vengono utilizzati i seguenti simboli di pericolo:

| Simbolo di pericolo | Significato |
|---|------------------------------------|
|  | Messaggio di avvertimento generico |
|  | Pericolo di scossa elettrica |
|  | Pericolo di esplosione |
|  | Rischio di ferite da taglio |

Utilizzo del documento





| Simbolo di pericolo | Significato |
|--|---|
|  | Pericolo di schiacciamento |
|  | Pericolo derivante da superfici calde |
|  | Pericolo derivante da forti campi magnetici |
|  | Pericolo derivante da radiazioni non ionizzanti |

Tabella 2: Simboli di pericolo

1.2.3 Struttura degli avvertimenti

Gli avvertimenti presenti in questo manuale hanno una forma e una struttura standardizzati.

| | |
|--|---|
|  | <div style="background-color: red; color: white; padding: 2px; text-align: center;"> PERICOLO</div> <p>Tipo e origine del pericolo! Possibili conseguenze in caso di pericolo/avvertimento ignorato.</p> <ul style="list-style-type: none"> ▸ Misure e divieti volti a prevenire il pericolo. |
|--|---|

L'esempio seguente mostra un avvertimento con rischio di folgorazione dovuto a componenti sotto tensione. È riportata la misura di precauzione per evitare il pericolo.

| | |
|--|--|
|  | <div style="background-color: red; color: white; padding: 2px; text-align: center;"> PERICOLO</div> <p>Rischio di scossa elettrica dovuto a componenti sotto tensione! Morte per folgorazione</p> <ul style="list-style-type: none"> ▸ Scollegare l'apparecchio dall'alimentazione per almeno 60 secondi prima di iniziare la riparazione. |
|--|--|

1.2.4 Simboli generici

Nel presente manuale vengono utilizzati i seguenti simboli generici:



| Simbolo generico | Significato |
|---|--|
|  | Identificazione di un suggerimento speciale (testo e/o grafica) |
|  | Identificazione di un suggerimento semplice (solo testo) |
|  | Identificazione di un link per un video tutorial |
|  | Identificazione degli strumenti necessari |
|  | Identificazione delle condizioni preve necessarie |
|  | Identificazione di una condizione (se ..., allora ...) |
|  | Identificazione di un risultato |
| [Avvio] | Identificazione di un tasto o di un pulsante |
| [00123456] | Identificazione di un codice articolo |
| Stato | Identificazione di un testo/finestra visualizzati (sul display dell'apparecchio) |

Tabella 3: Simboli generici

2.1 Note generali sulla sicurezza

2.1.1 Tutti gli elettrodomestici

Rischio di scosse elettriche dovute a componenti sotto tensione!

- La riparazione non conforme dei componenti elettrici può causare scosse elettriche!
- Scollegare l'apparecchio dall'alimentazione per almeno 60 secondi prima di iniziare il lavoro.
- Ultimata la riparazione, occorre eseguire un test di sicurezza conforme alla norma VDE 0701 o alle norme specifiche del Paese.

Rischio di lesioni causate da bordi taglienti!

- Indossare guanti di protezione.

Rischio di schiacciamento dovuto a componenti pesanti e in movimento durante la riparazione, la manutenzione, la ricerca dei guasti e l'assistenza

- Indossare calzature antinfortunistiche.
- Fissare i componenti pesanti per impedire che cadano.
- Non inserire parti del corpo nei componenti in movimento.







Rischio per il funzionamento o la sicurezza dell'apparecchio!

- Utilizzare solo ricambi originali.

Rischio di danneggiamento di componenti sensibili a carica elettrostatica (ESD)!

- Non toccare i moduli, inclusi i collegamenti e le piste conduttive.

Strumenti e ausili

| Designazione | Dettagli | Immagini |
|---|---|--|
| Strumento ausiliario [15000155] | Utensile per allentare i componenti in plastica |  |
| Cacciavite Torx T20 con foro [00340764] | 100 mm, per viti con perno di sicurezza |  |
| Chiave dinamometrica [15000441] | Chiave dinamometrica 20 - 100 Nm | |
| Cacciavite con punta piatta [00340854] | Lama 3,5 mm x 0,6 mm x 100 mm, isolamento di protezione 1000 V AC |  |
| Cacciavite con punta piatta [00340855] | Lama 5,5 mm x 1,0 mm x 125 mm, isolamento di protezione 1000 V AC |  |
| Pinze a becco tondo, struttura angolare [00341269] | Lunghezza 200 mm |  |
| Pinze per taglio laterale [00342182] | Lunghezza: 200 mm |  |

| Designazione | Dettagli | Immagini |
|----------------------------------|------------------------------------|---|
| Chiave combinata [00340811] | Dimensione della chiave 10°mm, M6 |  |
| Combination wrench [00340814] | Dimensione della chiave 13°mm, M8 |  |
| Chiave combinata [00340817] | Dimensione della chiave 17 mm, M10 |  |
| Chiave combinata [15000459] | Dimensione della chiave 16°mm, M10 |  |

4.1 Sostituzione del pannello comandi



ATTENZIONE

Alloggiamento con spigoli vivi!
Ferite da taglio
▶ Indossare guanti di protezione.



AVVERTENZA

Gli apparecchi inclinati possono scivolare!
Fratture / lesioni da schiacciamento
▶ Fissare gli apparecchi in modo che non scivolino.



ATTENZIONE

Rischio di caduta di componenti a causa di viti allentate!
Lesioni provocate dalla caduta di componenti.
▶ Fissare i componenti in modo che non cadano.



ATTENZIONE!

Rischio di caduta di componenti a causa di viti allentate!
Danni a altre parti dell'apparecchio o all'abitazione del cliente, ad es. parte inferiore.
▶ Fissare i componenti in modo che non cadano.

Prerequisiti:

- ✓ L'apparecchio è scollegato dalla rete elettrica.
- ✓ L'apparecchio è scollegato dalla rete idrica.
- ✓ L'apparecchio è liberamente accessibile.
- ✓ [Il cassetto del detersivo è stato rimosso. → 261](#)

4.1.1 Smontaggio del pannello comandi

1. Sganciare l'elemento di blocco (1).
2. Smontare la copertura (2).

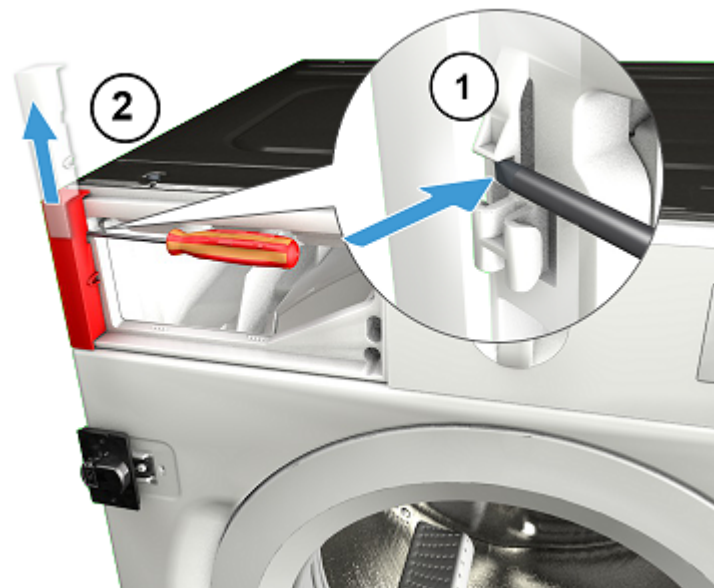

Riparazione

2. Rimuovere le viti.



3. 1. Sganciare gli elementi di blocco (1, 2).
2. Tirare in avanti il pannello comandi (3).

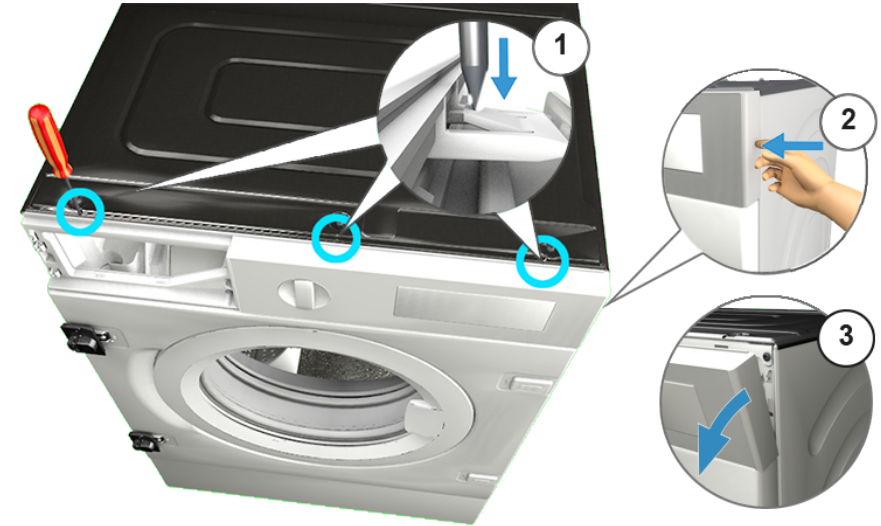

4. Smontare il pannello comandi.

4.1.2 Montaggio del pannello comandi

► Per il montaggio, seguire la procedura sopra descritta in senso opposto.

4.2 Sostituzione del cassetto del detersivo

Prerequisiti:

- ✓ L'apparecchio è scollegato dalla rete elettrica.
- ✓ L'apparecchio è scollegato dalla rete idrica.

4.2.1 Smontaggio del cassetto del detersivo

1. Estrarre il cassetto del detersivo.
2.
 1. Premere sulla linguetta (1).
 2. Rimuovere il cassetto del detersivo (2).

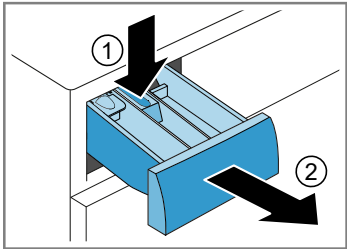

4.2.2 Montaggio del cassetto del detersivo

- ▶ Per il montaggio, seguire la procedura sopra descritta in senso opposto.

4.3 Sostituzione della maniglia del cassetto del detersivo

Prerequisiti:

- ✓ L'apparecchio è scollegato dalla rete elettrica.
- ✓ L'apparecchio è scollegato dalla rete idrica.
- ✓ [Il cassetto del detersivo è stato rimosso.→261](#)

4.3.1 Smontaggio della maniglia del cassetto del detersivo

1. Sganciare gli elementi di blocco.

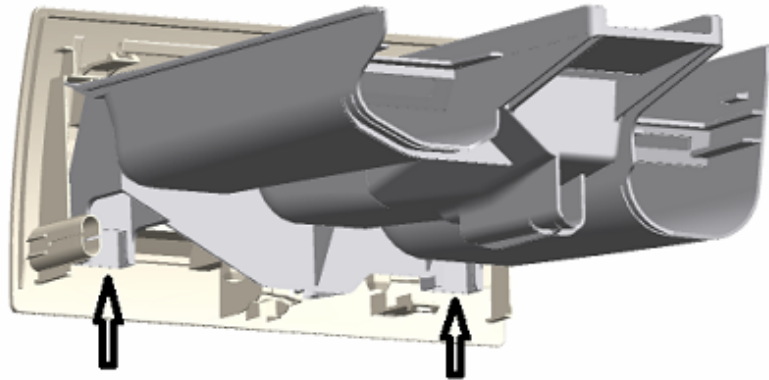

2. Rimuovere la maniglia del cassetto del detersivo.

4.3.2 Montaggio della maniglia del cassetto del detersivo

- ▶ Per il montaggio, seguire la procedura sopra descritta in senso opposto.

4.4 Sostituzione dell'oblò



ATTENZIONE

Zona della cerniera aperta!

Rischio di schiacciamento delle dita / di rimanere incastrati

- ▶ Non inserire le dita nella zona della cerniera.
- ▶ Indossare guanti di protezione.

Prerequisiti:

- ✔ L'apparecchio è scollegato dalla rete elettrica.
- ✔ L'apparecchio è scollegato dalla rete idrica.
- ✔ L'oblò è aperto.
- ✔ Il pannello mobile è stato smontato.

4.4.1 Smontaggio dell'oblò

1.



ATTENZIONE!

Rischio di caduta di componenti a causa di viti allentate!

Danni a altre parti dell'apparecchio o all'abitazione del cliente, ad es. parte inferiore.

- ▶ Fissare i componenti in modo che non cadano.



ATTENZIONE

Rischio di caduta di componenti a causa di viti allentate!

Lesioni provocate dalla caduta di componenti.

- ▶ Fissare i componenti in modo che non cadano.

Rimuovere le viti (1).

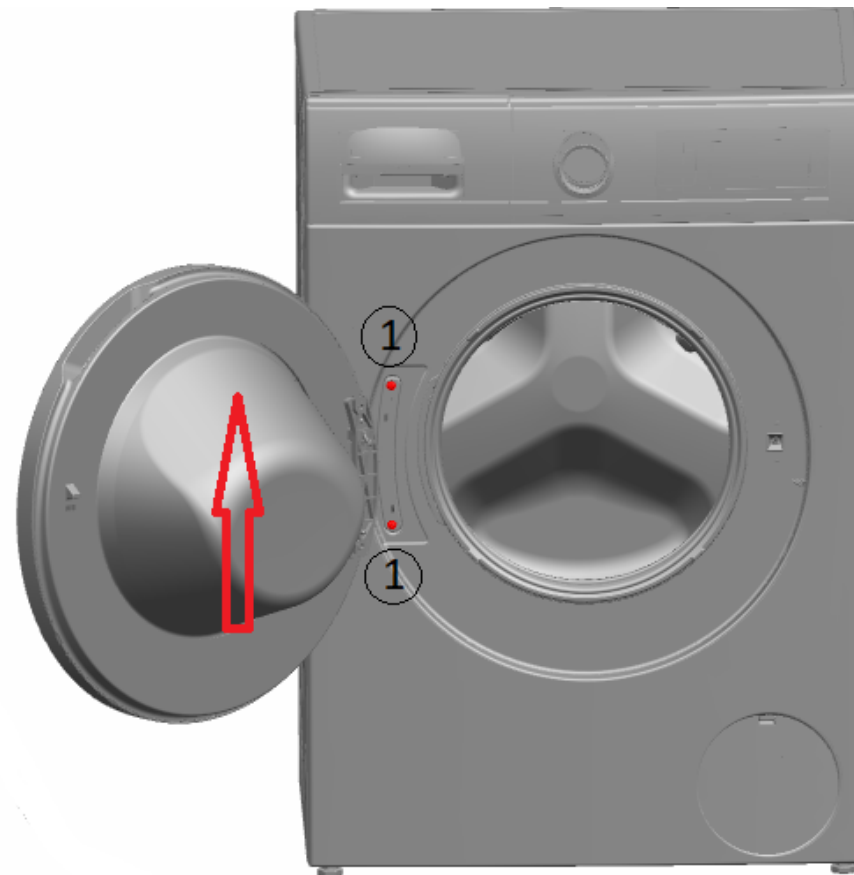

2. Smontare l'oblò sollevandolo.

4.4.2 Montaggio dell'oblò

- ▶ Per il montaggio, seguire la procedura sopra descritta in senso opposto.

4.5 Sostituzione dei componenti dell'oblò

| | |
|--|---|
|  | ⚠ ATTENZIONE |
| | Zona della cerniera aperta! Rischio di schiacciamento delle dita / di rimanere incastrati <ul style="list-style-type: none">▶ Non inserire le dita nella zona della cerniera.▶ Indossare guanti di protezione. |

Prerequisiti:

- ✓ L'apparecchio è scollegato dalla rete elettrica.
- ✓ L'apparecchio è scollegato dalla rete idrica.
- ✓ Il pannello mobile è stato smontato.
- ✓ [L'oblò è stato smontato. → 263](#)

4.5.1 Smontaggio dei componenti dell'oblò

- ▶ Smontare l'oblò procedendo dall'esterno verso l'interno.

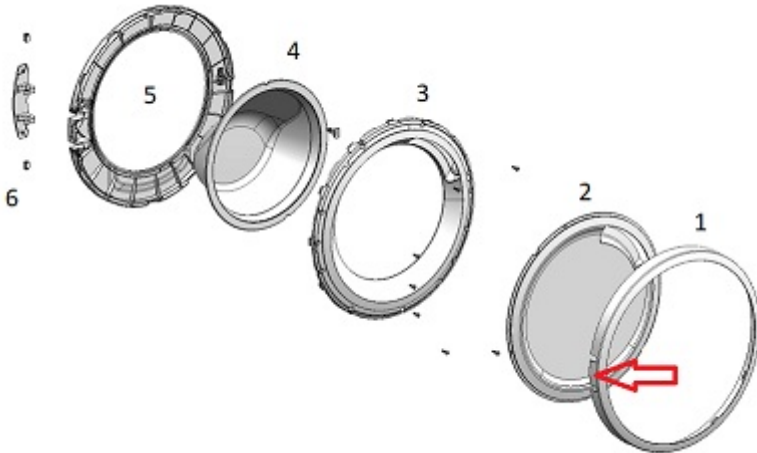

4.5.2 Montaggio dei componenti dell'oblò

- ▶ Per il montaggio, seguire la procedura sopra descritta in senso opposto.

4.6 Sostituzione della cerniera dell'oblò



ATTENZIONE

Zona della cerniera aperta!

Rischio di schiacciamento delle dita / di rimanere incastrati

- ▶ Non inserire le dita nella zona della cerniera.
- ▶ Indossare guanti di protezione.

Prerequisiti:

- ✔ L'apparecchio è scollegato dalla rete elettrica.
- ✔ L'apparecchio è scollegato dalla rete idrica.

4.6.1 Rimozione della cerniera dell'oblò

1. Rimuovere le due viti.
2. Smontare l'oblò.
3. Smontare l'oblò procedendo dall'esterno verso l'interno.

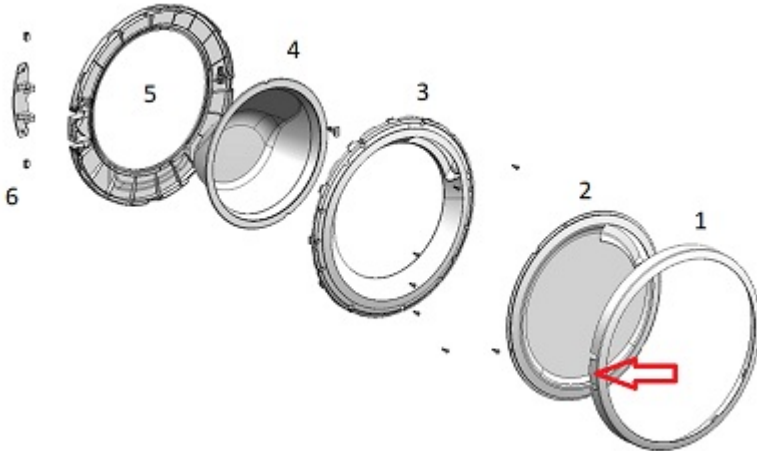



4. Smontare la cerniera dell'oblò.

4.6.2 Montaggio della cerniera dell'oblò

- ▶ Per il montaggio, seguire la procedura sopra descritta in senso opposto.

4.7 Sostituzione della guarnizione dell'oblò

| | |
|--|--|
|  | ATTENZIONE Alloggiamento con spigoli vivi! Ferite da taglio ▶ Indossare guanti di protezione. |
|--|--|

| | |
|--|---|
|  | ATTENZIONE Rischio di caduta di componenti a causa di viti allentate! Lesioni provocate dalla caduta di componenti. ▶ Fissare i componenti in modo che non cadano. |
|--|---|

| | |
|--|---|
|  | ATTENZIONE! Rischio di caduta di componenti a causa di viti allentate! Danni a altre parti dell'apparecchio o all'abitazione del cliente, ad es. parte inferiore. ▶ Fissare i componenti in modo che non cadano. |
|--|---|

Prerequisiti:

- ✓ L'apparecchio è scollegato dalla rete elettrica.
- ✓ L'apparecchio è scollegato dalla rete idrica.
- ✓ L'apparecchio è liberamente accessibile.
- ✓ [Il cassetto del detersivo è stato rimosso.→261](#)
- ✓ Il pannello comandi è stato smontato.
- ✓ [L'oblò è stato smontato.→263](#)
- ✓ [La copertura inferiore è stata rimossa.→271](#)

4.7.1 Rimozione della guarnizione dell'oblò

1. Allentare il fermo sulla luce del cestello.



2.

| | |
|---|---|
|  | ATTENZIONE! Rischio di danneggiare la superficie! La superficie dell'apparecchio potrebbe graffiarsi se si utilizzano attrezzi non adatti. ▶ Utilizzare solo attrezzi di plastica per sostituire l'anello a molla. |
|---|---|

Rimuovere l'anello a molla dalla guarnizione con un attrezzo di plastica.

3. Smontare la guarnizione dell'oblò dal pannello frontale.
4. Allentare il connettore del cavo dalla chiusura di sicurezza.

Riparazione

5. Allentare le viti nella sequenza indicata.



6. Rimuovere il pannello frontale.

7. Rimuovere il collegamento di tutti i tubi flessibili.

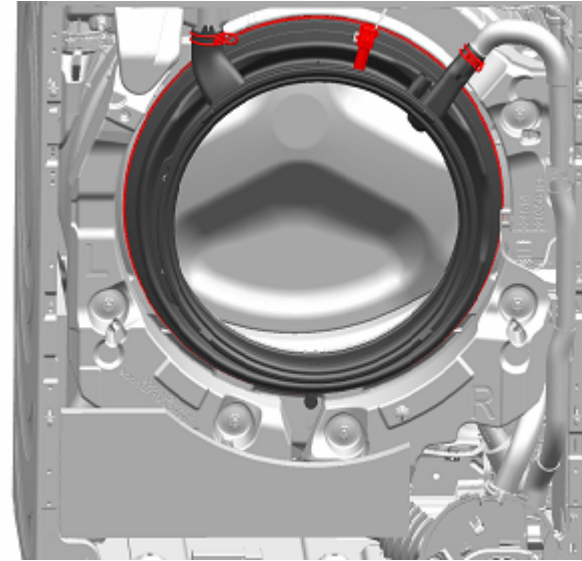

8. Rimuovere la guarnizione dell'oblò.

4.7.2 Installazione della guarnizione dell'oblò

► Per il montaggio, seguire la procedura sopra descritta in senso opposto.

4.8 Sostituzione del blocco porta

In qualità di società costruttrice, siamo tenuti a fornire ai consumatori una chiusura di sicurezza di ricambio incluse le istruzioni di riparazione in conformità al Regolamento (UE) 2019/2023. Tuttavia, desideriamo puntualizzare che, in seguito alla sostituzione della chiusura di sicurezza, un elettricista qualificato dovrà eseguire un test di sicurezza elettrotecnica prima di mettere in funzione l'apparecchio. La qualifica di tale incaricato deve essere verificata in conformità alle leggi, alle normative e alle disposizioni specifiche del Paese.

| | |
|--|--|
|  | PERICOLO |
| | Rischio di scosse elettriche dovute a componenti sotto tensione! Pericolo di morte dovuto a scosse elettriche in caso di riparazione non conforme <ul style="list-style-type: none">▶ Le parti elettriche devono essere riparate da elettricisti qualificati.▶ Ultimata la riparazione, occorre eseguire un test di sicurezza conforme alla norma VDE 0701 o alle norme specifiche del Paese. |

| | |
|--|--|
|  | ATTENZIONE |
| | Alloggiamento con spigoli vivi! Ferite da taglio <ul style="list-style-type: none">▶ Indossare guanti di protezione. |

| | |
|---|--|
|  | AVVERTENZA |
| | Gli apparecchi inclinati possono scivolare! Fratture / lesioni da schiacciamento <ul style="list-style-type: none">▶ Fissare gli apparecchi in modo che non scivolino. |

| | |
|--|---|
|  | ATTENZIONE |
| | Rischio di caduta di componenti a causa di viti allentate! Lesioni provocate dalla caduta di componenti. <ul style="list-style-type: none">▶ Fissare i componenti in modo che non cadano. |

| | |
|--|--|
|  | ATTENZIONE! |
| | Rischio di caduta di componenti a causa di viti allentate! Danni a altre parti dell'apparecchio o all'abitazione del cliente, ad es. parte inferiore. <ul style="list-style-type: none">▶ Fissare i componenti in modo che non cadano. |

Prerequisiti:

- ✓ L'apparecchio è scollegato dalla rete elettrica.
- ✓ L'apparecchio è scollegato dalla rete idrica.
- ✓ L'apparecchio è liberamente accessibile.
- ✓ Il pannello mobile è stato smontato.
- ✓ Il pannello comandi è stato smontato.
- ✓ [L'oblò è stato smontato. →263](#)
- ✓ L'anello a molla è stato smontato.
- ✓ Il pannello frontale è stato smontato.
- ✓ La guarnizione dell'oblò è stata smontata.

4.8.1 Smontaggio del blocco porta

1. Scollegare la spina del blocco porta.
2. Smontare il blocco porta.



3. Rimuovere il blocco porta.

4.8.2 Montaggio del blocco porta

Il blocco porta deve trovarsi in posizione corretta per garantire l'apertura di emergenza dell'oblò dell'apparecchio.

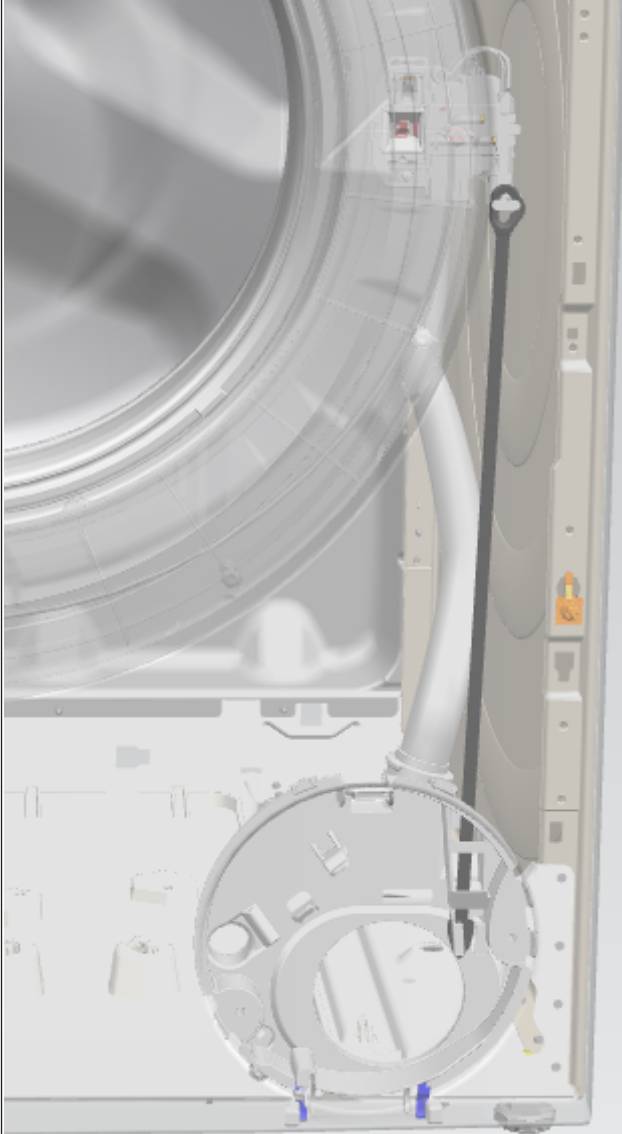



- ▶ Per il montaggio, seguire la procedura sopra descritta in senso opposto.

4.9 Sostituzione della luce del cestello

| | |
|--|--|
|  | ATTENZIONE Alloggiamento con spigoli vivi! Ferite da taglio ▶ Indossare guanti di protezione. |
|--|--|

| | |
|--|--|
|  | AVVERTENZA Gli apparecchi inclinati possono scivolare! Fratture / lesioni da schiacciamento ▶ Fissare gli apparecchi in modo che non scivolino. |
|--|--|

| | |
|--|---|
|  | ATTENZIONE Rischio di caduta di componenti a causa di viti allentate! Lesioni provocate dalla caduta di componenti. ▶ Fissare i componenti in modo che non cadano. |
|--|---|

| | |
|--|---|
|  | ATTENZIONE! Rischio di caduta di componenti a causa di viti allentate! Danni a altre parti dell'apparecchio o all'abitazione del cliente, ad es. parte inferiore. ▶ Fissare i componenti in modo che non cadano. |
|--|---|

Prerequisiti:

- ✓ L'apparecchio è scollegato dalla rete elettrica.
- ✓ L'apparecchio è scollegato dalla rete idrica.
- ✓ L'apparecchio è liberamente accessibile.
- ✓ [Il cassetto del detersivo è stato rimosso. → 261](#)
- ✓ Il pannello comandi è stato smontato.

4.9.1 Smontaggio della luce del cestello

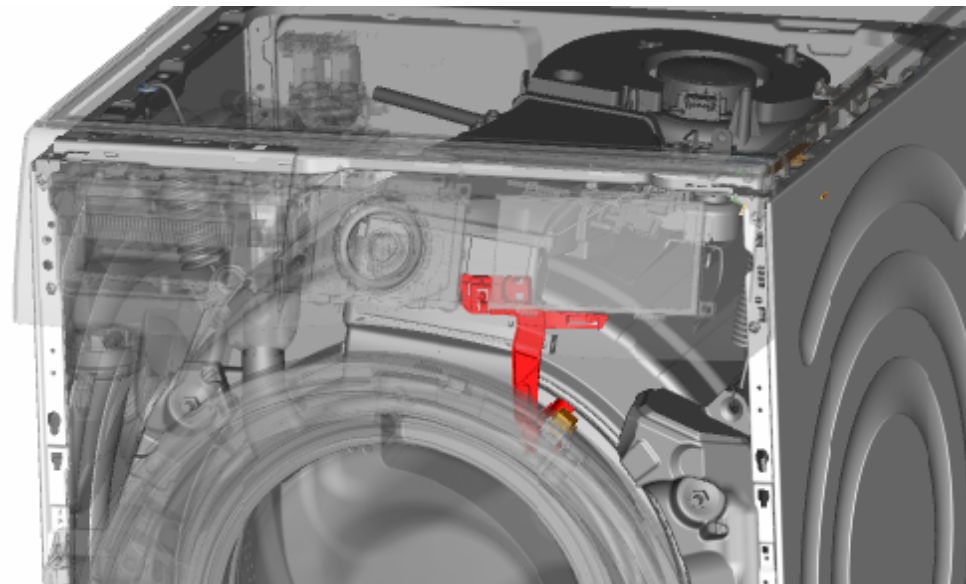

1. Estrarre dall'apparecchio il supporto della luce del cestello.
2. Staccare i collegamenti elettrici.
3. Rimuovere la luce del cestello dal suo supporto.

4.9.2 Montaggio della luce del cestello

- ▶ Per il montaggio, seguire la procedura sopra descritta in senso opposto.

4.10 Sostituzione della copertura inferiore



Fig. 1: Copertura del gruppo inferiore

Prerequisiti:

- ✓ L'apparecchio è scollegato dalla rete elettrica.
- ✓ L'apparecchio è scollegato dalla rete idrica.
- ✓ Il pannello mobile è stato smontato.

4.10.1 Smontaggio della copertura inferiore

Prerequisiti:

- ✓ L'apparecchio è scollegato dalla rete elettrica.
- ✓ L'apparecchio è scollegato dalla rete idrica.

1. Smontare la copertura inferiore.

2. Staccare il tubo flessibile dal supporto.



Riparazione

3. 1. Allentare la vite (1).
2. Premere sul punto di fermo e rimuovere tirando verso il basso (2).

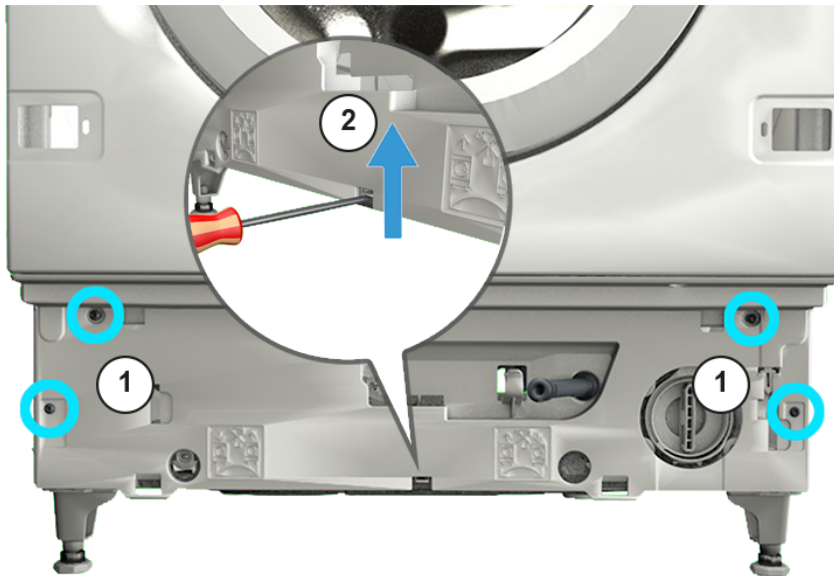

4. Rimuovere la copertura del gruppo inferiore tirandola in avanti.

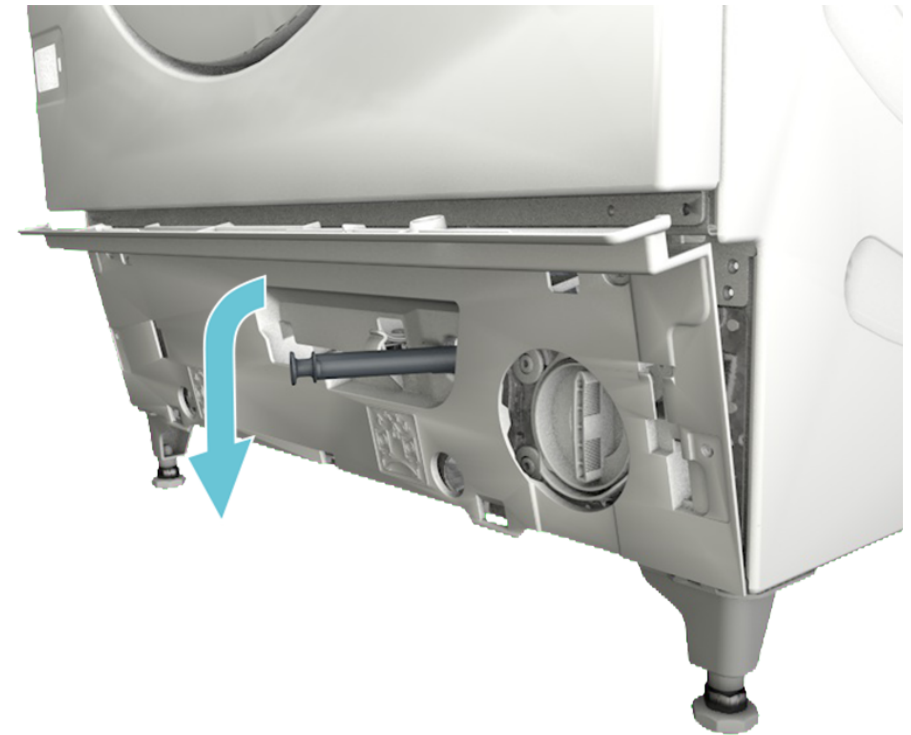

5. Estrarre il tubo flessibile dalla copertura.

4.10.2 Montaggio della copertura

- Per il montaggio, seguire la procedura sopra descritta in senso opposto.

4.11 Sostituzione del pannello frontale



ATTENZIONE

Alloggiamento con spigoli vivi!

Ferite da taglio

- ▶ Indossare guanti di protezione.

Prerequisiti:

- ✓ L'apparecchio è scollegato dalla rete elettrica.
- ✓ L'apparecchio è scollegato dalla rete idrica.
- ✓ L'apparecchio è liberamente accessibile.
- ✓ [Il cassetto del detersivo è stato rimosso. → 261](#)
- ✓ Il pannello mobile è stato smontato.
- ✓ [L'oblò è stato smontato. → 263](#)
- ✓ La guarnizione dell'oblò è stata smontata.

4.11.1 Smontaggio del pannello frontale

1. Allentare il fermo sulla luce del cestello.

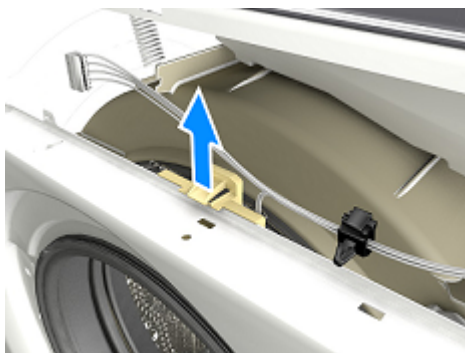

2.



ATTENZIONE

Rischio di caduta di componenti a causa di viti allentate!

Lesioni provocate dalla caduta di componenti.

- ▶ Fissare i componenti in modo che non cadano.



ATTENZIONE!

Rischio di caduta di componenti a causa di viti allentate!

Danni a altre parti dell'apparecchio o all'abitazione del cliente, ad es. parte inferiore.

- ▶ Fissare i componenti in modo che non cadano.

Allentare le viti nella sequenza indicata.







3. Rimuovere il pannello frontale.

4.11.2 Montaggio del pannello frontale

- ▶ Per il montaggio, seguire la procedura sopra descritta in senso opposto.

Informācija par remontu - Veļas mazgājamā mašīna

| | | | |
|--|------------|--|-----|
|  Par šo dokumentu | 276 | 4.8 Durtiņu slēga nomaiņa..... | 289 |
| 1.1 Būtiska informācija | 276 | 4.8.1 Durtiņu slēga noņemšana | 289 |
| 1.1.1 Mērķis | 276 | 4.8.2 Durtiņu slēga uzstādīšana | 290 |
| 1.2 Simbolu skaidrojums..... | 276 | 4.9 Bunduļa lampiņas nomaiņa..... | 291 |
| 1.2.1 Bīstamības līmeņi | 276 | 4.9.1 Bunduļa lampiņas izņemšana..... | 291 |
| 1.2.2 Bīstamības simboli | 276 | 4.9.2 Bunduļa lampiņas uzstādīšana | 291 |
| 1.2.3 Brīdinājumu struktūra | 277 | 4.10 Apakšējā vāka nomaiņa | 292 |
| 1.2.4 Vispārīgie simboli..... | 277 | 4.10.1 Apakšējā vāka noņemšana | 292 |
|  Drošība | 278 | 4.10.2 Vāka uzstādīšana | 293 |
| 2.1 Vispārējie drošības norādījumi | 278 | 4.11 Priekšējā paneļa nomaiņa | 294 |
| 2.1.1 Visām mājsaimniecības ierīcēm | 278 | 4.11.1 Priekšējā paneļa noņemšana | 294 |
|  Piederumi un palīgļīdzekļi | 279 | 4.11.2 Priekšējā paneļa uzstādīšana..... | 295 |
|  Remonts | 280 | | |
| 4.1 Fascijas paneļa nomaiņa | 280 | | |
| 4.1.1 Fascijas paneļa noņemšana | 280 | | |
| 4.1.2 Fascijas paneļa uzstādīšana | 281 | | |
| 4.2 Mazgāšanas līdzekļa atvilktnes nomaiņa..... | 282 | | |
| 4.2.1 Mazgāšanas līdzekļa atvilktnes izņemšana..... | 282 | | |
| 4.2.2 Mazgāšanas līdzekļa atvilktnes uzstādīšana..... | 282 | | |
| 4.3 Mazgāšanas līdzekļa atvilktnes roktura nomaiņa | 283 | | |
| 4.3.1 Mazgāšanas līdzekļa atvilktnes roktura izņemšana | 283 | | |
| 4.3.2 Mazgāšanas līdzekļa atvilktnes roktura uzstādīšana | 283 | | |
| 4.4 Durtiņu nomaiņa | 284 | | |
| 4.4.1 Durtiņu noņemšana | 284 | | |
| 4.4.2 Durtiņu uzstādīšana | 284 | | |
| 4.5 Durtiņu detaļu nomaiņa | 285 | | |
| 4.5.1 Durtiņu daļu noņemšana..... | 285 | | |
| 4.5.2 Durtiņu daļu uzstādīšana | 285 | | |
| 4.6 Durtiņu eņģu nomaiņa..... | 286 | | |
| 4.6.1 Durtiņu eņģu noņemšana | 286 | | |
| 4.6.2 Durtiņu eņģes uzstādīšana | 286 | | |
| 4.7 Durtiņu blīves nomaiņa | 287 | | |
| 4.7.1 Durtiņu blīves noņemšana | 287 | | |
| 4.7.2 Durtiņu blīvējuma uzstādīšana | 288 | | |

i Par šo dokumentu

1.1 Būtiska informācija

1.1.1 Mērķis

Šie labošanas ieteikumi ir paredzēti patērētājam, lai patstāvīgi labotu ierīces, saskaņā ar piemērojamo Ekodizaina regulu (sākot no 03.2021.).





Ir sniegta informācija, kā nomainīt noteiktas rezerves daļas, un brīdinājumi, kā arī ir aprakstīti riski.

Ja ir jautājumi, sazinieties ar mūsu klientu apkalpošanas dienestu. Mēs atbildam par zaudējumiem tikai tad, ja šie labošanas ieteikumi ir pienācīgi ievēroti.

1.2 Simbolu skaidrojums

1.2.1 Bīstamības līmeņi

Brīdinājuma līmeņus veido simbols un signālvārds. Signālvārds apzīmē bīstamības pakāpi.





| Brīdinājuma līmenis | Nozīme |
|--|---|
|  BĪSTAMI | Brīdinājuma paziņojuma neievērošanas rezultātā iestāsies nāve vai radīsies smagas traumas. |
|  BRĪDINĀJUMS | Brīdinājuma paziņojuma neievērošanas rezultātā var iestāties nāve vai rasties smagas traumas. |
|  ESJET PIESARDŽĪGI | Brīdinājuma paziņojuma neievērošanas rezultātā var rasties nelielas traumas. |
|  UZMANĪBU! | Brīdinājuma paziņojuma neievērošanas rezultātā var rasties kaitējums īpašumam. |

Tabula 1: Bīstamības līmeņi



1.2.2 Bīstamības simboli

Bīstamības simboli ir simboliski apzīmējumi, kas sniedz norādes par bīstamības veidu.

Šajā dokumentā ir izmantoti šādi bīstamības simboli:

| Bīstamības simbols | Nozīme |
|---|--|
|  | Vispārējs brīdinājuma paziņojums |
|  | Elektriskā sprieguma radīts apdraudējums |
|  | Sprādzienbīstamības risks |
|  | Griezumu bīstamība |
|  | Saspiešanas bīstamība |

i Par šo dokumentu

| Bīstamības simbols | Nozīme |
|--|---|
|  | Karstu virsmu radīta bīstamība |
|  | Spēcīgu magnētisko lauku radīta bīstamība |
|  | Nejonizējoša starojuma radīta bīstamība |

Tabula 2: Bīstamības simboli

1.2.3 Brīdinājumu struktūra

Šajā dokumentā sniegtajiem brīdinājumiem ir standartizēts noformējums un standartizēta struktūra.



| | |
|--|--|
|  | <p>⚠ BĪSTAMI</p> <p>Bīstamības veids un avots! Iespējamās sekas, kas rodas, neievērojot bīstamības paziņojumu / brīdinājumu.</p> <ul style="list-style-type: none"> ▶ Bīstamības novēršanas pasākumi un aizliegumi. |
|--|--|





Nākamajā piemērā ir parādīts brīdinājums, kas apzīmē elektrotrieciena risku, ko rada spriegumaktīvas detaļas. Ir norādīts bīstamības novēršanas pasākums.

| | |
|--|---|
|  | <p>⚠ BĪSTAMI</p> <p>Elektrotrieciena risks, ko rada spriegumaktīvas detaļas! Nāvējošs elektrotrieciens</p> <ul style="list-style-type: none"> ▶ Atvienojiet iekārtas no strāvas padeves vismaz 60 sekundes pirms labošanas sākšanas. |
|--|---|

1.2.4 Vispārīgie simboli

Šajā dokumentā ir izmantoti šādi vispārīgie simboli:

| Visp. simbols | Nozīme |
|--|---|
|  | Īpašu ieteikumu apzīmējums (teksts un/ vai grafika) |
|  | Vienkāršu ieteikumu apzīmējums (tikai teksts) |

| Visp. simbols | Nozīme |
|---|---|
|  | Video pamācības saites apzīmējums |
|  | Nepieciešamo rīku apzīmējums |
|  | Nepieciešamo priekšnosacījumu apzīmējums |
|  | Nosacījuma apzīmējums (ja ..., tad ...) |
|  | Rezultāta apzīmējums |
| [Sākt] | Taustiņa vai pogas apzīmējums |
| [00123456] | Materiāla numura apzīmējums |
| Statuss | Attēlotā teksta / loga apzīmējums (iekārtas displejā) |

Tabula 3: Vispārīgie simboli

2.1 Vispārējie drošības norādījumi

2.1.1 Visām mājsaimniecības ierīcēm

Elektrotrieciena risks spriegumaktīvu daļu dēļ!

- Ja remonts, kas skar elektriskās daļas, ir veikts kļūdaini, pastāv elektrotrieciena risks!
- Ierīcei ir jābūt atvienotai no tīkla vismaz 60 sekundes, pirms sāk darbu.
- Pēc remonta ierīces drošība ir jāpārbauda atbilstīgi noteikumiem VDE 0701 vai valsts noteikumiem.

Savainojumu risks asu malu dēļ!

- Valkājiet aizsargcimdus.

Saspiešanas risks labošanas, uzturēšanas, traucējumu novēršanas un apkopes laikā, ko rada smagas un kustīgas detaļas

- Valkājiet aizsargapavus.
- Nostipriniet smagas detaļas, lai tās nenokristu.
- Neievietojiet ķermeņa daļas kustīgās detaļās.







Ierīces drošības / darbības traucējuma risks!





- Izmantojiet tikai oriģinālās rezerves daļas.

Pret elektrostatisko izlādi jutīgu daļu (ESDS) bojājuma risks!

- Neaiztieciet moduļus, ieskaitot savienojumus un vadojumu.

Piederumi un palīglīdzekļi

| Apzīmējums | Sīkāka informācija | Attēli |
|--|---|--|
| Papildu instruments [15000155] | Instrumenti plastmasas detaļu atvienošanai |  |
| Skrūvgriezis Torx T20 ar urbumu [00340764] | 100 mm, skrūvēm ar drošības tapiņu |  |
| Momentatslēga [15000441] | Momentatslēga: 20–100 Nm | |
| Plakans skrūvgriezis [00340854] | Izmērs: 3,5 mm x 0,6 mm x 100 mm, aizsargizolācija: 1000 V maiņstrāva |  |
| Plakans skrūvgriezis [00340855] | Izmērs: 5,5 mm x 1,0 mm x 125 mm, aizsargizolācija: 1000 V maiņstrāva |  |
| Asknaibles, izliektas [00341269] | Garums: 200 mm |  |
| Sānknaibles [00342182] | Garums: 200 mm |  |

| Apzīmējums | Sīkāka informācija | Attēli |
|--|-----------------------------|---|
| Kombinētā uzgriežņu atslēga [00340811] | Atslēgas platums 10°mm, M6 |  |
| Combination wrench [00340814] | Atslēgas platums 13°mm, M8 |  |
| Kombinētā uzgriežņu atslēga [00340817] | Atslēgas platums 17 mm, M10 |  |
| Kombinētā uzgriežņu atslēga [15000459] | Atslēgas platums 16°mm, M10 |  |

4.1 Fascijas paneļa nomaiņa



⚠ ESIET PIESARDZĪGI

Asas korpusa malas!
Griezumu traumas
▶ Valkājiet aizsargcimdus.



⚠ BRĪDINĀJUMS

Sasvērušos ierīču paslīdēšana!
Kaulu lūzumi / saspiešanas traumas
▶ Nostipriniet ierīces, lai tās neslīdētu.



⚠ ESIET PIESARDZĪGI

Krītošu detaļu risks, ko izraisa vaļīgās skrūves!
Krītošu detaļu izraisītas traumas.
▶ Nostipriniet detaļu, lai tā nenokristu.



UZMANĪBU!

Krītošu detaļu risks, ko izraisa vaļīgās skrūves!
Citu ierīces detaļu bojājumi vai bojājumi, kas rodas klienta mājās, piem., apakšpuse.
▶ Nostipriniet detaļu, lai tā nenokristu.

Prasība:

- ✓ Ierīcei ir jābūt atvienotai no strāvas padeves.
- ✓ Ierīcei ir jābūt atvienotai no ūdens padeves.
- ✓ Ierīcei var netraucēti piekļūt.
- ✓ [Izņemta mazgāšanas līdzekļa atvilktnē. → 282](#)

4.1.1 Fascijas paneļa noņemšana

1. Atvienojiet stiprinājuma elementu (1).
2. Noņemiet vāku (2).

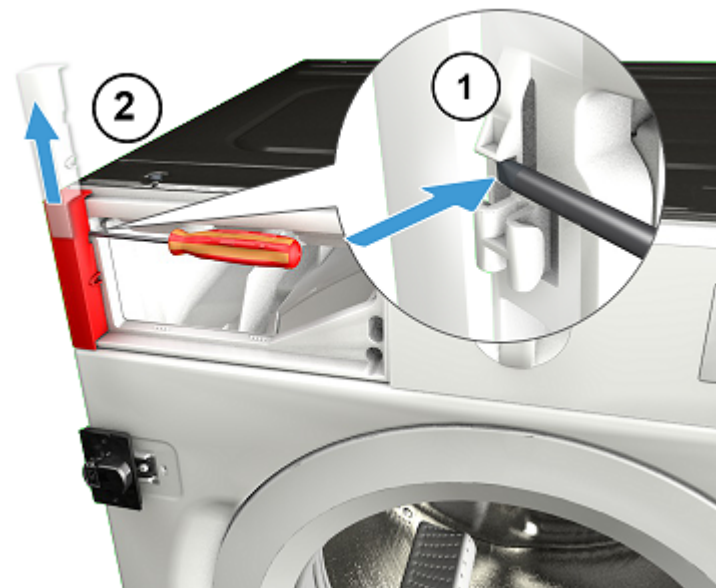

2. Izskrūvējiet skrūves.



3. 1. Atvienojiet stiprinājuma elementus (1, 2).
2. Pavelciet fascijas paneli uz priekšpusi (3).

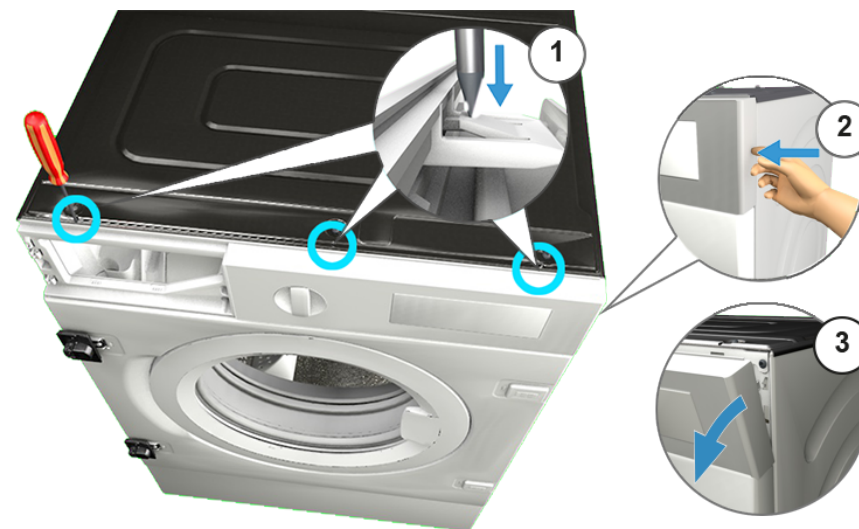

4. Noņemiet fascijas paneli.

4.1.2 Fascijas paneļa uzstādīšana

- Uzstādiet apgrieztā kārtībā.

4.2 Mazgāšanas līdzekļa atvilktnes nomaiņa

Prasība:

- ✓ Ierīcei ir jābūt atvienotai no strāvas padeves.
- ✓ Ierīcei ir jābūt atvienotai no ūdens padeves.

4.2.1 Mazgāšanas līdzekļa atvilktnes izņemšana

1. Izvelciet mazgāšanas līdzekļa atvilktni.
2. 1. Nospiediet ieliktni lejup (1).
2. Izņemiet mazgāšanas līdzekļa atvilktni (2).

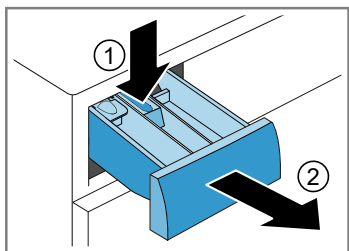

4.2.2 Mazgāšanas līdzekļa atvilktnes uzstādīšana

- ▶ Uzstādiet apgrieztā kārtībā.

4.3 Mazgāšanas līdzekļa atvilktnes roktura nomainīšana

Prasība:

- ✓ Ierīcei ir jābūt atvienotai no strāvas padeves.
- ✓ Ierīcei ir jābūt atvienotai no ūdens padeves.
- ✓ [Izņemta mazgāšanas līdzekļa atvilktnē.](#) →282

4.3.1 Mazgāšanas līdzekļa atvilktnes roktura izņemšana

1. Atvienojiet stiprinājuma elementus.

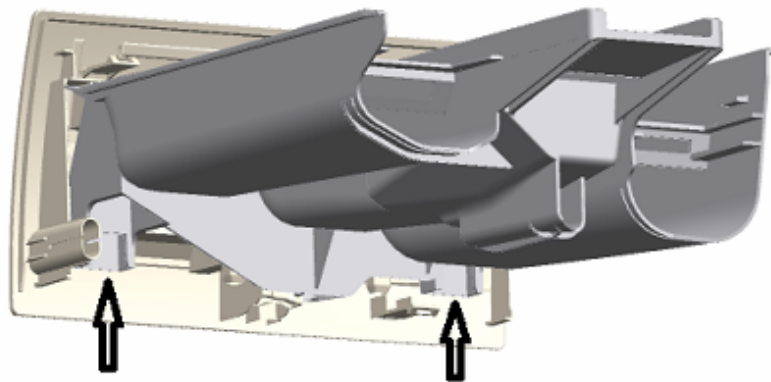

2. Noņemiet mazgāšanas līdzekļa atvilktnes rokturi.

4.3.2 Mazgāšanas līdzekļa atvilktnes roktura uzstādīšana

- ▶ Uzstādiet apgrieztā kārtībā.

4.4 Durtiņu nomaiņa



⚠ ESIET PIESARDZĪGI

Atveriet eņģu nodalījumu!

Pirkstu saspiešana / iesprūšana

- ▶ Neievietojiet rokas eņģu nodalījumā.
- ▶ Valkājiet aizsargcimdus.

Prasība:

- ✔ Ierīcei ir jābūt atvienotai no strāvas padeves.
- ✔ Ierīcei ir jābūt atvienotai no ūdens padeves.
- ✔ Atvērtas durtiņas.
- ✔ Noņemts mēbeļu panelis.

4.4.1 Durtiņu noņemšana

1.



UZMANĪBU!

Krītošu detaļu risks, ko izraisa vaļīgas skrūves!

Citu ierīces detaļu bojājumi vai bojājumi, kas rodas klienta mājās, piem., apakšpuse.

- ▶ Nostipriniet detaļu, lai tā nenokristu.



⚠ ESIET PIESARDZĪGI

Krītošu detaļu risks, ko izraisa vaļīgas skrūves!

Krītošu detaļu izraisītas traumas.

- ▶ Nostipriniet detaļu, lai tā nenokristu.

Izskrūvējiet skrūves (1).

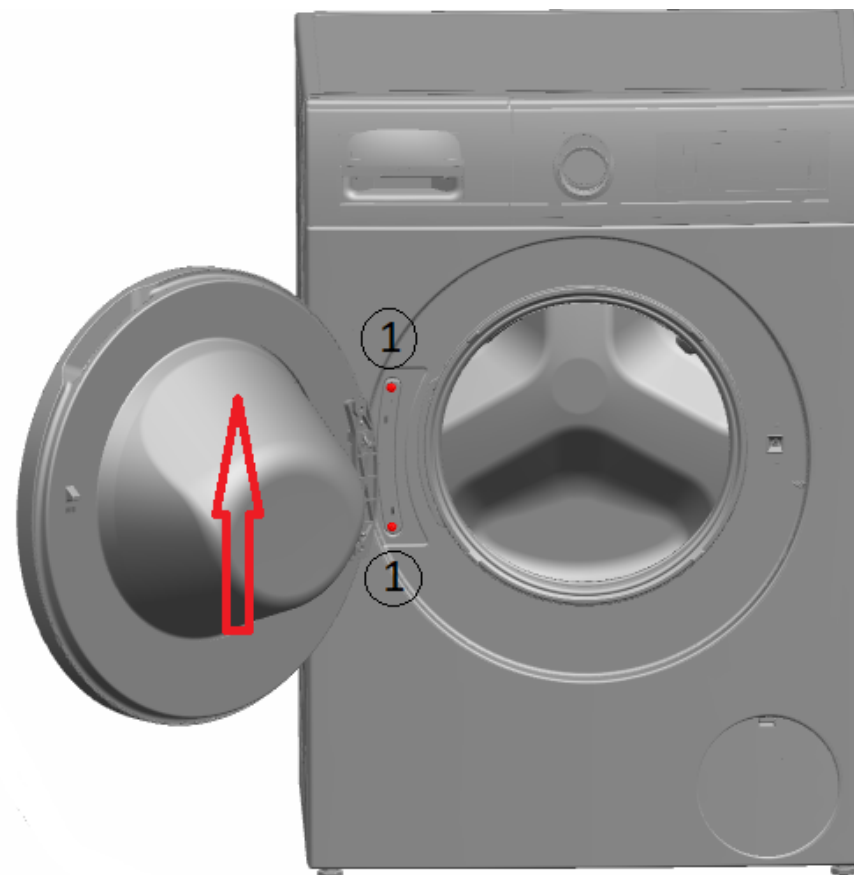

2. Virziet durtiņas augšup.

4.4.2 Durtiņu uzstādīšana

- ▶ Uzstādiet apgrieztā kārtībā.

4.5 Durtiņu detaļu nomaīņa



⚠ ESIET PIESARDZĪGI

Atveriet eņģu nodalījumu!

Pirkstu saspiešana / iesprūšana

- ▶ Neievietojiet rokas eņģu nodalījumā.
- ▶ Valkājiet aizsargcimdus.

Prasība:

- ✓ Ierīcei ir jābūt atvienotai no strāvas padeves.
- ✓ Ierīcei ir jābūt atvienotai no ūdens padeves.
- ✓ Noņemts mēbeļu panelis.
- ✓ [Durtiņas ir noņemtas.→284](#)

4.5.1 Durtiņu daļu noņemšana

- ▶ Izjauciet durtiņas no ārpuses uz iekšpusi.

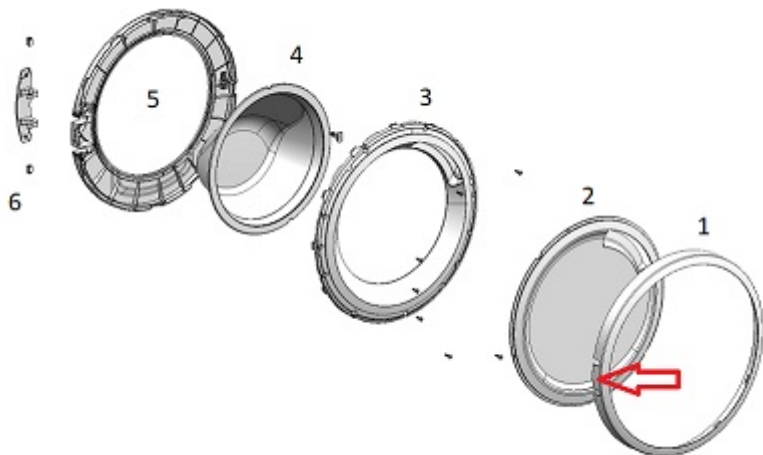

4.5.2 Durtiņu daļu uzstādīšana

- ▶ Uzstādiet apgrieztā kārtībā.

4.6 Durtiņu eņģu nomaīņa



⚠ ESIET PIESARDZĪGI

Atveriet eņģu nodalījumu!

Pirkstu saspiešana / iesprūšana

- ▶ Neievietojiet rokas eņģu nodalījumā.
- ▶ Valkājiet aizsargcimdus.

Prasība:

- ✓ Ierīcei ir jābūt atvienotai no strāvas padeves.
- ✓ Ierīcei ir jābūt atvienotai no ūdens padeves.

4.6.1 Durtiņu eņģu noņemšana

1. Atskrūvējiet divas skrūves.
2. Noņemiet durtiņas.
3. Izjauciet durtiņas no ārpuses uz iekšpusi.

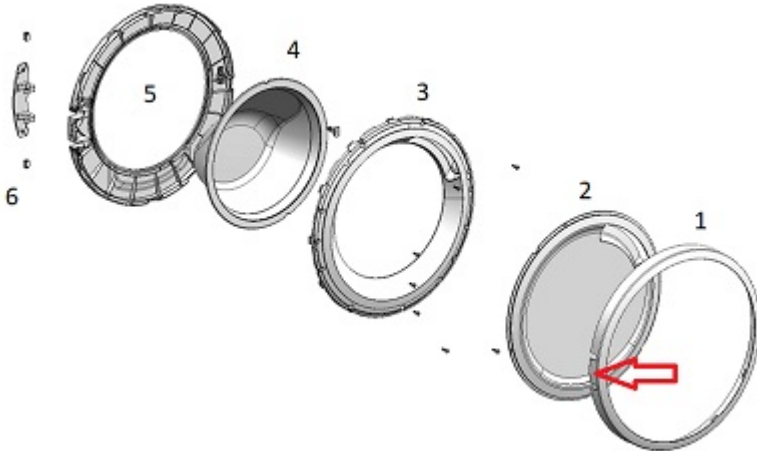

4. Noņemiet durtiņu eņģi.

4.6.2 Durtiņu eņģes uzstādīšana

- ▶ Uzstādiet apgrieztā kārtībā.

4.7 Durtiņu blīves nomaiņa



⚠ ESIET PIESARDZĪGI

Asas korpusa malas!
Griezumu traumas
▶ Valkājiet aizsargcimdus.



⚠ ESIET PIESARDZĪGI

Krītošu detaļu risks, ko izraisa vaļīgās skrūves!
Krītošu detaļu izraisītas traumas.
▶ Nostipriniet detaļu, lai tā nenokristu.



UZMANĪBU!

Krītošu detaļu risks, ko izraisa vaļīgās skrūves!
Citu ierīces detaļu bojājumi vai bojājumi, kas rodas klienta mājās, piem., apakšpuse.
▶ Nostipriniet detaļu, lai tā nenokristu.

Prasība:

- ✓ Ierīcei ir jābūt atvienotai no strāvas padeves.
- ✓ Ierīcei ir jābūt atvienotai no ūdens padeves.
- ✓ Ierīcei var netraucēti piekļūt.
- ✓ [Izņemta mazgāšanas līdzekļa atvilktnē.→282](#)
- ✓ Fascijas panelis ir noņemts.
- ✓ [Durtiņas ir noņemtas.→284](#)
- ✓ [Noņemts apakšējais vāks.→292](#)

4.7.1 Durtiņu blīves noņemšana

1. Atlaidiet vaļīgāk bunduļa lampiņas aizturi.



- 2.



UZMANĪBU!

Bojātu virsmu risks!

Lietojot neatbilstošus instrumentus, ierīces virsmai var rasties skrāpējumi.
▶ Izmantojiet tikai plastmasas instrumentus, lai nomainītu spriegotāja gredzenu.

Ar plastmasas instrumentu noņemiet spriegotāja gredzenu no blīvslēga.

3. Noņemiet durvju blīvi no priekšējā paneļa.
4. Atvienojiet vada savienotāju no durvju slēga.

5. Atskrūvējiet skrūves norādītajā kārtībā.



6. Noņemiet priekšējo paneli.

7. Atvienojiet visus cauruļu savienojumus.

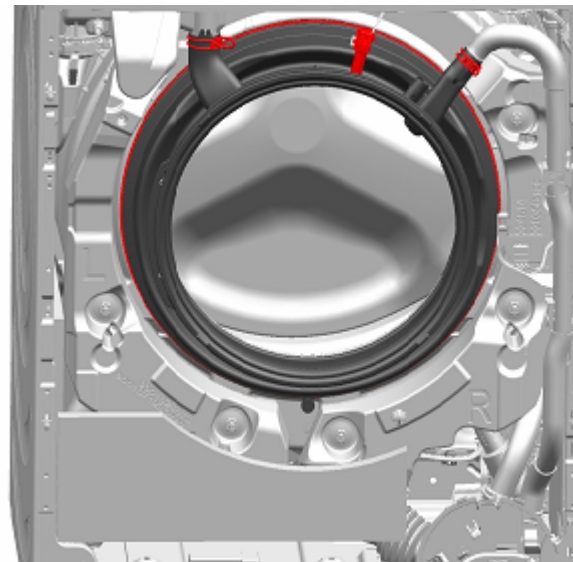

8. Noņemiet durtiņu blīvējumu.

4.7.2 Durtiņu blīvējuma uzstādīšana

- ▶ Uzstādiet apgrieztā kārtībā.

4.8 Durtiņu slēga nomaiņa

Atbilstīgi Regulai (ES) 2019/2023 mums kā ražotājam ir jānodrošina patērētājiem rezerves durvju slēdzene, ieskaitot remonta instrukciju. Tomēr vēlamies norādīt, ka pēc durvju slēdzenes maiņas kvalificētam elektriķim ir jāpārbauda ierīces elektrodrošība, pirms to sāk darbināt. Elektriķim ir jāvar uzrādīt savu kvalifikāciju atbilstīgi valsts tiesību aktiem, noteikumiem un prasībām.

| | |
|--|---|
|  | <p style="text-align: center;">⚠ BĪSTAMI</p> <p>Elektrotrieciena risks spriegumaktīvu daļu dēļ! Dzīvības apdraudējums nepareiza remonta izraisīta elektrotrieciena dēļ</p> <ul style="list-style-type: none"> ▶ Elektriskās daļas ir jāremontē kvalificētam elektriķim. ▶ Pēc remonta ierīces drošība ir jāpārbauda atbilstīgi noteikumiem VDE 0701 vai valsts noteikumiem. |
|  | <p style="text-align: center;">⚠ ESIET PIESARDŽĪGI</p> <p>Asas korpusa malas! Griezumu traumas</p> <ul style="list-style-type: none"> ▶ Valkājiet aizsargcimdus. |
|  | <p style="text-align: center;">⚠ BRĪDINĀJUMS</p> <p>Sasvērušos ierīču paslīdēšana! Kaulu lūzumi / saspiešanas traumas</p> <ul style="list-style-type: none"> ▶ Nostipriniet ierīces, lai tās neslīdētu. |
|  | <p style="text-align: center;">⚠ ESIET PIESARDŽĪGI</p> <p>Krītošu detaļu risks, ko izraisa vaļīgas skrūves! Krītošu detaļu izraisītas traumas.</p> <ul style="list-style-type: none"> ▶ Nostipriniet detaļu, lai tā nenokristu. |
|  | <p style="text-align: center;">UZMANĪBU!</p> <p>Krītošu detaļu risks, ko izraisa vaļīgas skrūves! Citu ierīces detaļu bojājumi vai bojājumi, kas rodas klienta mājās, piem., apakšpuse.</p> <ul style="list-style-type: none"> ▶ Nostipriniet detaļu, lai tā nenokristu. |

Prasība:

- ✓ Ierīcei ir jābūt atvienotai no strāvas padeves.
- ✓ Ierīcei ir jābūt atvienotai no ūdens padeves.

- ✓ Ierīcei var netraucēti piekļūt.
- ✓ Noņemts mēbeļu panelis.
- ✓ Fascijas panelis ir noņemts.
- ✓ [Durtiņas ir noņemtas. → 284](#)
- ✓ Spriegotāja gredzens ir noņemts.
- ✓ Priekšējais panelis ir noņemts.
- ✓ Durtiņu blīvējums ir noņemts.

4.8.1 Durtiņu slēga noņemšana

1. Atvienojiet durtiņu slēga spraudni.
2. Atbrīvojiet durtiņu slēgu.



3. Noņemiet durtiņu slēgu.

4.8.2 Durtiņu slēga uzstādīšana

Durtiņu slēgam ir jāatrodas pareizajā pozīcijā, lai nodrošinātu, ka iespējama ierīces durtiņu atvēršana ārkārtas situācijā.



- ▶ Uzstādiet apgrieztā kārtībā.

4.9 Bunduļa lampiņas nomaiņa



⚠ ESIET PIESARDZĪGI

Asas korpusa malas!
Griezumu traumas
▶ Valkājiet aizsargcimdus.



⚠ BRĪDINĀJUMS

Sasvērušos ierīču paslīdēšana!
Kaulu lūzumi / saspiešanas traumas
▶ Nostipriniet ierīces, lai tās neslīdētu.



⚠ ESIET PIESARDZĪGI

Krītošu detaļu risks, ko izraisa vaļīgās skrūves!
Krītošu detaļu izraisītas traumas.
▶ Nostipriniet detaļu, lai tā nenokristu.



UZMANĪBU!

Krītošu detaļu risks, ko izraisa vaļīgās skrūves!
Citu ierīces detaļu bojājumi vai bojājumi, kas rodas klienta mājās, piem., apakšpuse.
▶ Nostipriniet detaļu, lai tā nenokristu.

Prasība:

- ✓ Ierīcei ir jābūt atvienotai no strāvas padeves.
- ✓ Ierīcei ir jābūt atvienotai no ūdens padeves.
- ✓ Ierīcei var netraucēti piekļūt.
- ✓ [Izņemta mazgāšanas līdzekļa atvilktnē. → 282](#)
- ✓ Fascijas panelis ir noņemts.

4.9.1 Bunduļa lampiņas izņemšana

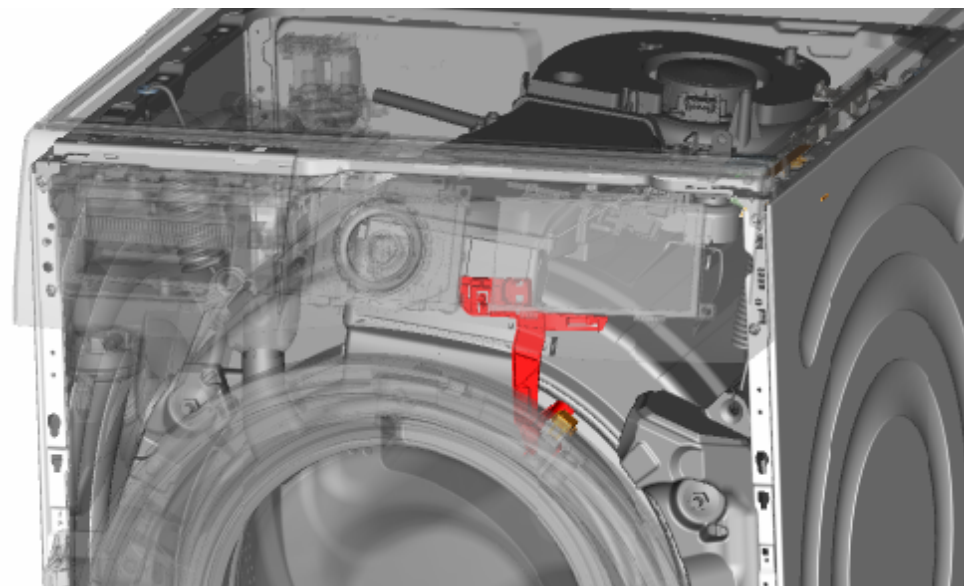

1. Izvelciet bunduļa lampiņas turētāju no ierīces.
2. Atvienojiet elektrosavienojumus.
3. Izņemiet bunduļa lampiņu no bunduļa lampiņas turētāja.

4.9.2 Bunduļa lampiņas uzstādīšana

- ▶ Uzstādiet apgrieztā kārtībā.

4.10 Apakšējā vāka nomaiņa



Att. 1: Apakšējā grupējuma nomaiņa

Prasība:

- ✓ Ierīcei ir jābūt atvienotai no strāvas padeves.
- ✓ Ierīcei ir jābūt atvienotai no ūdens padeves.
- ✓ Noņemts mēbeļu panelis.

4.10.1 Apakšējā vāka noņemšana

Prasība:

- ✓ Ierīcei ir jābūt atvienotai no strāvas padeves.
- ✓ Ierīcei ir jābūt atvienotai no ūdens padeves.

1. Noņemiet apakšējo vāku.

2. Atvienojiet caurulīti no turētāja.



🔧 Remonts

3. 1. Atskrūvējiet skrūvi (1).
2. Nospiediet stiprinājuma punktu un noņemiet, virzot lejup (2).

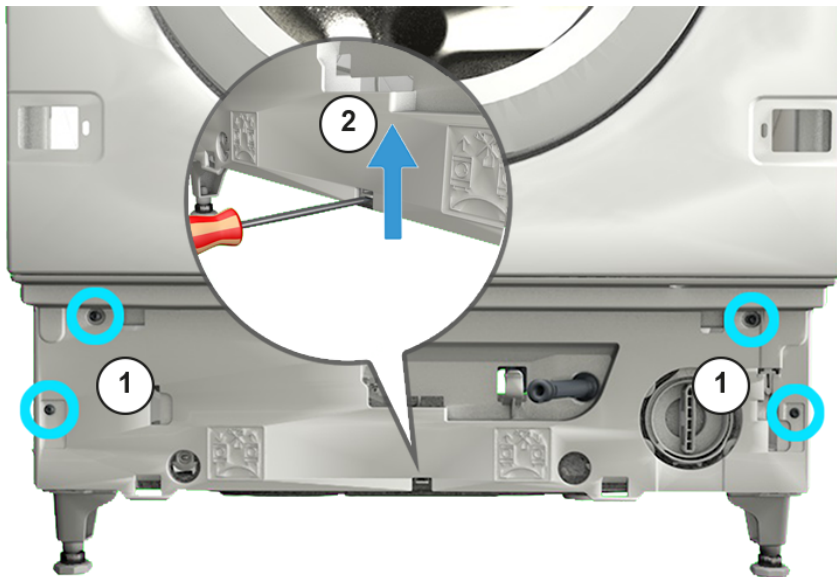

4. Pavelciet grupējuma vāku lejup un noņemiet, virzot uz priekšu.



5. Izvelciet caurulīti no vāka.

4.10.2 Vāka uzstādīšana

- ▶ Uzstādiet apgrieztā kārtībā.

4.11 Priekšējā paneļa nomainīšana



⚠ ESIET PIESARDZĪGI

Asas korpusa malas!

- Griezumu traumas
- ▶ Valkājiet aizsargcimdus.

Prasība:

- ✓ Ierīcei ir jābūt atvienotai no strāvas padeves.
- ✓ Ierīcei ir jābūt atvienotai no ūdens padeves.
- ✓ Ierīcei var netraucēti piekļūt.
- ✓ [Izņemta mazgāšanas līdzekļa atvilktnē. → 282](#)
- ✓ Noņemts mēbeļu panelis.
- ✓ [Durtiņas ir noņemtas. → 284](#)
- ✓ Durtiņu blīvējums ir noņemts.

4.11.1 Priekšējā paneļa noņemšana

1. Atlaidiet vaļīgāk bunduļa lampiņas aizzīduri.

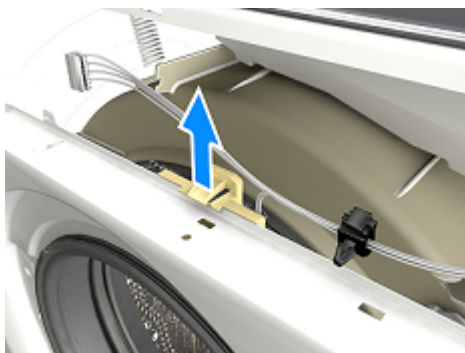

2.



⚠ ESIET PIESARDZĪGI

Krītošu detaļu risks, ko izraisa vaļīgas skrūves!

- Krītošu detaļu izraisītas traumas.
- ▶ Nostipriniet detaļu, lai tā nenokristu.



UZMANĪBU!

Krītošu detaļu risks, ko izraisa vaļīgas skrūves!

- Citu ierīces detaļu bojājumi vai bojājumi, kas rodas klienta mājās, piem., apakšpuse.
- ▶ Nostipriniet detaļu, lai tā nenokristu.

Atskrūvējiet skrūves norādītajā kārtībā.







3. Noņemiet priekšējo paneli.

4.11.2 Priekšējā paneļa uzstādīšana

▶ Uzstādiet apgriezta kārtībā.

Informacija apie remontą - Skalbyklė

| | |
|--|------------|
|  Dėl šio dokumento | 297 |
| 1.1 Svarbi informacija | 297 |
| 1.1.1 Paskirtis | 297 |
| 1.2 Simbolių paaiškinimas | 297 |
| 1.2.1 Pavojaus lygiai | 297 |
| 1.2.2 Pavojaus simboliai | 297 |
| 1.2.3 Įspėjimų struktūra | 298 |
| 1.2.4 Bendrieji simboliai | 298 |
|  Sauga | 299 |
| 2.1 Bendrosios saugos instrukcijos..... | 299 |
| 2.1.1 Visi buitiniai prietaisai | 299 |
|  Įrankiai ir pagalbinės priemonės | 300 |
|  Remontas | 301 |
| 4.1 Antjuostės keitimas..... | 301 |
| 4.1.1 Antjuostės nuėmimas | 301 |
| 4.1.2 Antjuostės uždėjimas | 302 |
| 4.2 Skalbiklio stalčiaus keitimas | 303 |
| 4.2.1 Skalbiklio stalčiaus išėmimas | 303 |
| 4.2.2 Skalbiklio stalčiaus įdėjimas..... | 303 |
| 4.3 Skalbiklio stalčiaus dangtelio keitimas..... | 304 |
| 4.3.1 Skalbiklio stalčiaus dangtelio nuėmimas | 304 |
| 4.3.2 Skalbiklio stalčiaus dangtelio uždėjimas | 304 |
| 4.4 Durelių keitimas..... | 305 |
| 4.4.1 Durelių nuėmimas | 305 |
| 4.4.2 Durelių uždėjimas | 305 |
| 4.5 Durelių konstrukcinių dalių keitimas | 306 |
| 4.5.1 Durelių konstrukcinių dalių nuėmimas..... | 306 |
| 4.5.2 Durelių konstrukcinių dalių uždėjimas | 306 |
| 4.6 Durelių vyro keitimas..... | 307 |
| 4.6.1 Durelių vyro nuėmimas | 307 |
| 4.6.2 Durelių vyro uždėjimas | 307 |
| 4.7 Durelių sandariklio keitimas..... | 308 |
| 4.7.1 Durelių sandariklio nuėmimas | 308 |
| 4.7.2 Durelių sandariklio uždėjimas | 309 |

| | |
|---|-----|
| 4.8 Durelių užrakto keitimas | 310 |
| 4.8.1 Durelių užrakto nuėmimas..... | 310 |
| 4.8.2 Durelių užrakto sumontavimas | 311 |
| 4.9 Būgno apšvietimo keitimas | 312 |
| 4.9.1 Būgno apšvietimo nuėmimas..... | 312 |
| 4.9.2 Būgno apšvietimo sumontavimas | 312 |
| 4.10 Apatinio dangčio keitimas | 313 |
| 4.10.1 Apatinio dangčio nuėmimas | 313 |
| 4.10.2 Dangčio uždėjimas | 314 |
| 4.11 Priekinio skydo keitimas | 315 |
| 4.11.1 Priekinio skydo nuėmimas..... | 315 |
| 4.11.2 Priekinio skydo uždėjimas | 316 |

i Dėl šio dokumento

1.1 Svarbi informacija

1.1.1 Paskirtis

Šios remonto nuorodos padeda naudotojui pataisyti prietaisus patiems pagal galiojantį ekologinio projektavimo reglamentą (2021 m. kovo mėn. redakcija).



Jose pateikta informacija, kaip pakeisti tam tikras atsargines dalis, įskaitant ir įspėjimus bei riziką.

Jei kiltų klausimų, kreipkitės į mūsų klientų aptarnavimo tarnybą. Mes atsakysime už žalą tik tuo atveju, jei bus tinkamai laikomasi remonto nuorodų.

1.2 Simbolių paaiškinimas

1.2.1 Pavojaus lygiai

Įspėjimo lygiai susideda iš simbolio ir signalinio žodžio. Signalinis žodis nurodo pavojaus sunkumą.





| Įspėjimo lygis | Reikšmė |
|--|--|
|  PAVOJUS | Nepaisant įspėjamojo pranešimo, ištinka mirtis arba sunkūs sužalojimai. |
|  ĮSPĖJIMAS | Nepaisant įspėjamojo pranešimo, gali ištikti mirtis arba sunkūs sužalojimai. |
|  PERSPĖJIMAS | Nepaisant įspėjamojo pranešimo, galimi nedideli sužalojimai. |
|  DĖMESIO! | Nepaisant įspėjamojo pranešimo, gali būti sugadintas turtas. |

Lentelė 1: Pavojaus lygiai



1.2.2 Pavojaus simboliai

Pavojaus simboliai yra simboliniai atvaizdai, nurodantys pavojaus rūšį.

Šiame: dokumente naudojami tokie pavojaus simboliai

| Pavojaus simbolis | Reikšmė |
|---|--------------------------------|
|  | Bendras įspėjamasis pranešimas |
|  | Pavojinga elektros įtampa |
|  | Sprogimo pavojus |
|  | Įpjovimo pavojus |
|  | Prispaudimo pavojus |

i Dėl šio dokumento

| Pavojaus simbolis | Reikšmė |
|--|---|
|  | Pavojus dėl karštų paviršių |
|  | Pavojus dėl stipraus magnetinio lauko |
|  | Pavojus dėl nejonizuojančiosios spinduliuotės |

Lentelė 2: Pavojaus simboliai

1.2.3 Įspėjimų struktūra

Šiame dokumente pateikiami įspėjimai yra standartizuotos išvaizdos ir standartizuotos struktūros.



| | |
|--|---|
|  | <p>⚠ PAVOJUS</p> <p>Pavojaus tipas ir šaltinis! Galimos pasekmės, jei nepaisoma pavojaus / įspėjimo.</p> <ul style="list-style-type: none"> ▶ Priemonės ir draudimai pavojui išvengti. |
|--|---|





Šiame pavyzdyje parodytas įspėjimas, įspėjantis apie elektros smūgį dėl dalių su įtampa. Paminėta priemonė, kaip išvengti pavojaus.

| | |
|---|---|
|  | <p>⚠ PAVOJUS</p> <p>Elektros smūgio pavojus dėl dalių, kuriose yra įtampa! Mirtis dėl elektros smūgio</p> <ul style="list-style-type: none"> ▶ Prieš pradėdami remontą, ne mažiau kaip prieš 60 sekundžių atjunkite prietaisus nuo elektros tiekimo. |
|---|---|

1.2.4 Bendrieji simboliai

Šiame dokumente naudojami tokie bendrieji simboliai:

| Bendr. simbolis | Reikšmė |
|--|--|
|  | Žymi specialų patarimą (tekstas ir (arba) grafika) |
|  | Žymi paprastą patarimą (tik tekstas) |
|  | Žymi nuorodą į vaizdo pamoką |

| Bendr. simbolis | Reikšmė |
|---|---|
|  | Žymi reikalingus įrankius |
|  | Žymi reikalingas prielaidas |
|  | Žymi sąlygą (jei ..., tai ...) |
|  | Žymi rezultatą |
| [Paleisti] | Žymi klavišą arba ekrano mygtuką |
| [00123456] | Žymi dalies numerį |
| Būsena | Žymi rodomą tekstą / langą (prietaiso ekrane) |

Lentelė 3: Bendrieji simboliai

2.1 Bendrosios saugos instrukcijos

2.1.1 Visi būtiniai prietaisai

Elektros smūgio pavojus dėl dalių, kuriose yra įtampa!

- Elektrinių konstrukcinių dalių remonto klaidos gali sukelti elektros smūgį!
- Prieš pradėdami dirbti, ne mažiau kaip prieš 60 sekundžių atjunkite prietaisą nuo maitinimo.
- Po remonto pasirūpinkite, kad būtų atliktas saugos bandymas pagal VDE 0701 arba šalyje galiojančius reglamentus.

Pavojus susižeisti į aštrias briaunas!

- Mūvėkite apsaugines pirštines.

Prispaudimo rizika remonto, einamosios techninės priežiūros, sutrikimų šalinimo ir techninės priežiūros metu dėl sunkių ir judančių konstrukcinių dalių

- Avėkite apsauginius batus.
- Apsaugokite sunkias konstrukcines dalis, kad jos nenukristų.
- Neartinkite kūno dalių prie judančių konstrukcinių dalių.







Rizika prietaiso saugai / veikimui!





- Naudokite tik originalias atsargines dalis.

Elektrostatškai jautrių konstrukcinių dalių (ESD) pažeidimo rizika!

- Nelieskite modulių, o taip pat ir jų jungčių bei laidininkų kelių.

Įrankiai ir pagalbinės priemonės

| Paskyrimas | Išsami informacija | Vaizdai |
|---|--|--|
| Pagalbinis įrankis [15000155] | Įrankis plastikinėms dalims atpalaiduoti |  |
| „Torx T20“ atsuktuvą su kiauryme [00340764] | 100 mm, varžtams su saugos kaiščiu |  |
| Dinamometrinis veržliaraktis [15000441] | Dinamometrinis veržliaraktis 20–100 Nm | |
| Atsuktuvą su įpjova [00340854] | Mentė 3,5 mm x 0,6 mm x 100 mm, apsauginė izoliacija 1000 V AC |  |
| Atsuktuvą su įpjova [00340855] | Mentė 5,5 mm x 1,0 mm x 125 mm, apsauginė izoliacija 1000 V AC |  |
| Adatinės replės, kampinės [00341269] | Ilgis 200 mm |  |
| Šonu pjaunančios replės [00342182] | Ilgis: 200 mm |  |

| Paskyrimas | Išsami informacija | Vaizdai |
|--------------------------------------|--------------------------------------|---|
| Kombinuotas veržliaraktis [00340811] | Rakto plotis 10 ^o mm, M6 |  |
| Combination wrench [00340814] | Rakto plotis 13 ^o mm, M8 |  |
| Kombinuotas veržliaraktis [00340817] | Rakto plotis 17 mm, M10 |  |
| Kombinuotas veržliaraktis [15000459] | Rakto plotis 16 ^o mm, M10 |  |

4.1 Antjuostės keitimas



⚠ PERSPĖJIMAS

Aštrios korpuso briaunos!

Galima įsijauti

- ▶ Mūvėkite apsaugines pirštines.



⚠ ĮSPĖJIMAS

Paverstų prietaisų slydimas!

Galimi kaulų lūžiai ir prispaudimai

- ▶ Apsaugokite prietaisus, kad jie nepaslystų.



⚠ PERSPĖJIMAS

Pavojus, kad atpalaidavus varžtus dalys nukris!

Krentančios dalys gali sužeisti.

- ▶ Apsaugokite konstrukcinę dalį, kad ji nenukristų.



DĖMESIO!

Pavojus, kad atpalaidavus varžtus dalys nukris!

Gali būti sugadintos kitos prietaiso dalys arba kliento namai, pvz., grindys.

- ▶ Apsaugokite konstrukcinę dalį, kad ji nenukristų.

Reikalavimas.

- ✓ Prietaisas atjungtas nuo maitinimo šaltinio.
- ✓ Prietaisas atjungtas nuo vandens tiekimo.
- ✓ Prietaisai yra laisvai prieinami.
- ✓ [Išimtas skalbiklio stalčius.→303](#)

4.1.1 Antjuostės nuėmimas

1. Atpalaiduokite spraudę (1).
2. Nuimkite dangtelį (2).

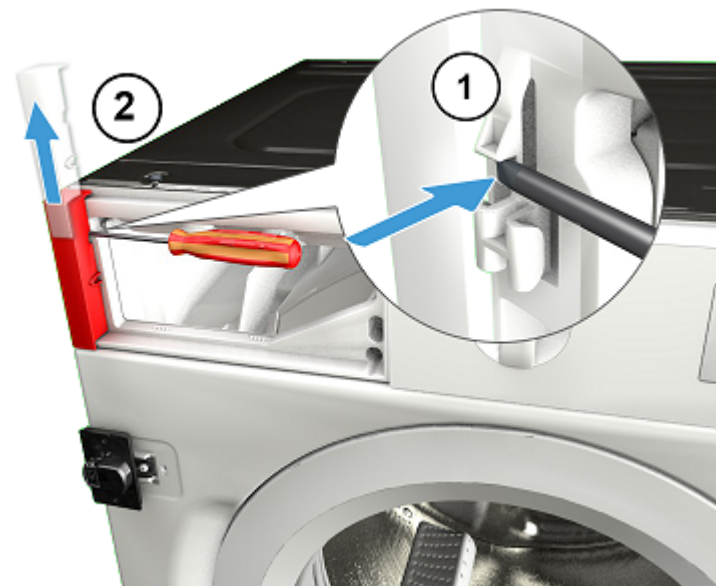

2. Išsukite varžtus.



3. 1. Atpalaiduokite spraudes (1, 2).
2. Patraukite antjuostę pirmyn (3).

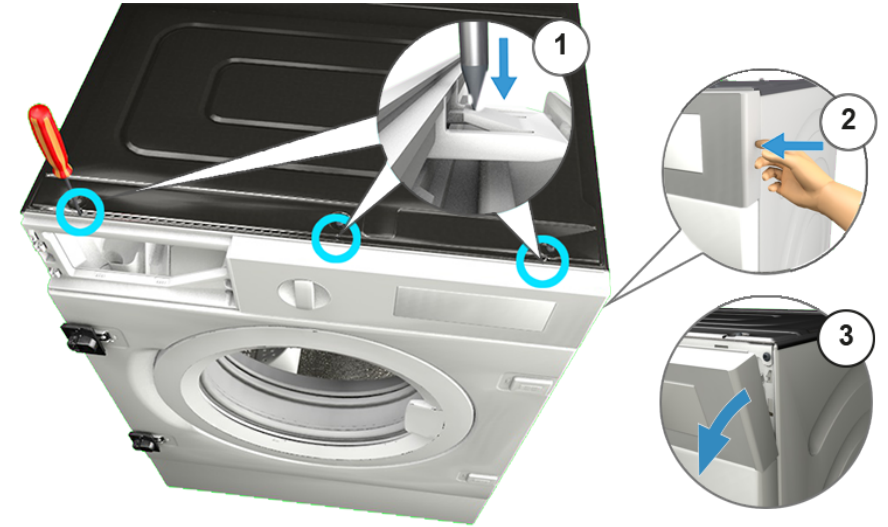

4. Nuimkite antjuostę.

4.1.2 Antjuostės uždėjimas

► Uždėkite atvirkščia eilės tvarka.

4.2 Skalbiklio stalčiaus keitimas

Reikalavimas.

- ✓ Prietaisas atjungtas nuo maitinimo šaltinio.
- ✓ Prietaisas atjungtas nuo vandens tiekimo.

4.2.1 Skalbiklio stalčiaus išėmimas

1. Ištraukite skalbiklio stalčių.
2. 1. Paspauskite įdėklą (1) žemyn.
2. Išimkite skalbiklio stalčių (2).

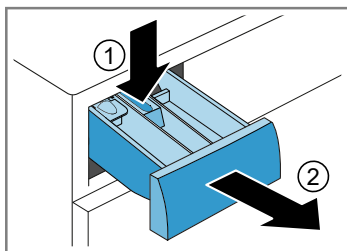

4.2.2 Skalbiklio stalčiaus įdėjimas

- ▶ Uždėkite atvirkščia eilės tvarka.

4.3 Skalbiklio stalčiaus dangtelio keitimas

Reikalavimas.

- ✔ Prietaisas atjungtas nuo maitinimo šaltinio.
- ✔ Prietaisas atjungtas nuo vandens tiekimo.
- ✔ [Išimtas skalbiklio stalčius.→303](#)

4.3.1 Skalbiklio stalčiaus dangtelio nuėmimas

1. Atpalaiduokite spraudes.

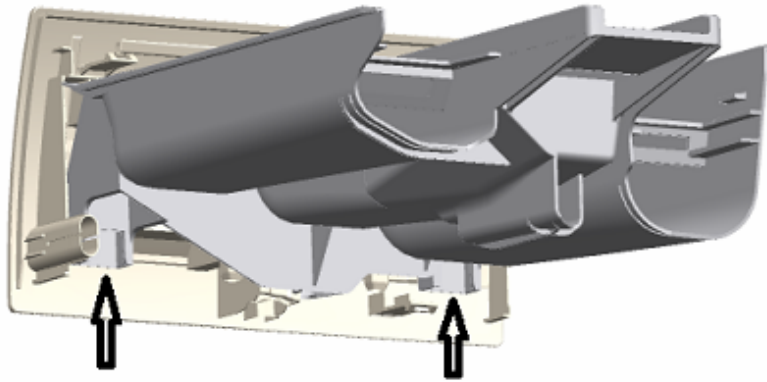

2. Nuimkite skalbiklio stalčiaus dangtelį.

4.3.2 Skalbiklio stalčiaus dangtelio uždėjimas

- ▶ Uždėkite atvirkščia eilės tvarka.

4.4 Durelių keitimas



⚠️ PERSPĖJIMAS

Atvira vyrių sritis!

Galima prispausti / prisiverti pirštus

- ▶ Nekiškite rankų į vyrių sritį.
- ▶ Mūvėkite apsaugines pirštines.

Reikalavimas.

- ✔ Prietaisas atjungtas nuo maitinimo šaltinio.
- ✔ Prietaisas atjungtas nuo vandens tiekimo.
- ✔ Durelės atidarytos.
- ✔ Baldinė plokštė nuimta.

4.4.1 Durelių nuėmimas

1.



DĖMESIO!

Pavojus, kad atpalaidavus varžtus dalys nukris!

Gali būti sugadintos kitos prietaiso dalys arba kliento namai, pvz., grindys.

- ▶ Apsaugokite konstrukcinę dalį, kad ji nenukristų.



⚠️ PERSPĖJIMAS

Pavojus, kad atpalaidavus varžtus dalys nukris!

Krentančios dalys gali sužeisti.

- ▶ Apsaugokite konstrukcinę dalį, kad ji nenukristų.

Išsukite varžtus (1).

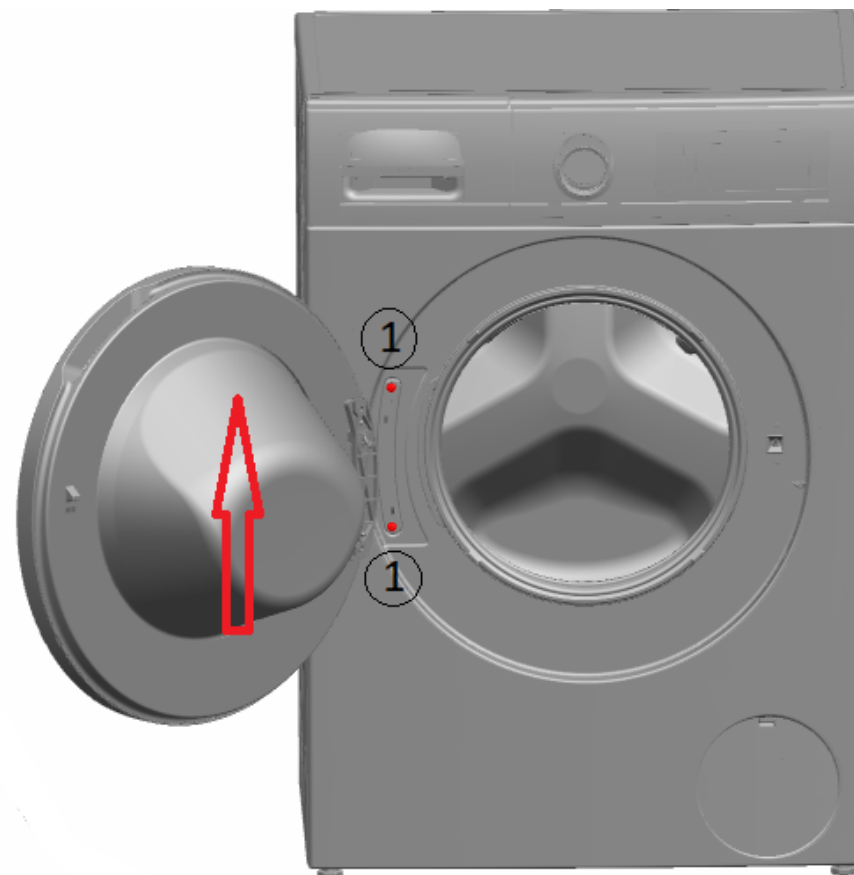

2. Nuimkite dureles, keldami aukštyn.

4.4.2 Durelių uždėjimas

- ▶ Uždėkite atvirkščia eilės tvarka.

4.5 Durelių konstrukcinių dalių keitimas



⚠ PERSPĖJIMAS

Atvira vyrių sritis!

Galima prisispausti / prisiverti pirštus

- ▶ Nekiškite rankų į vyrių sritį.
- ▶ Mūvėkite apsaugines pirštines.

Reikalavimas.

- ✔ Prietaisas atjungtas nuo maitinimo šaltinio.
- ✔ Prietaisas atjungtas nuo vandens tiekimo.
- ✔ Baldinė plokštė nuimta.
- ✔ [Durelės nuimtos.→305](#)

4.5.1 Durelių konstrukcinių dalių nuėmimas

- ▶ Išardykite dureles nuo išorės vidaus link.

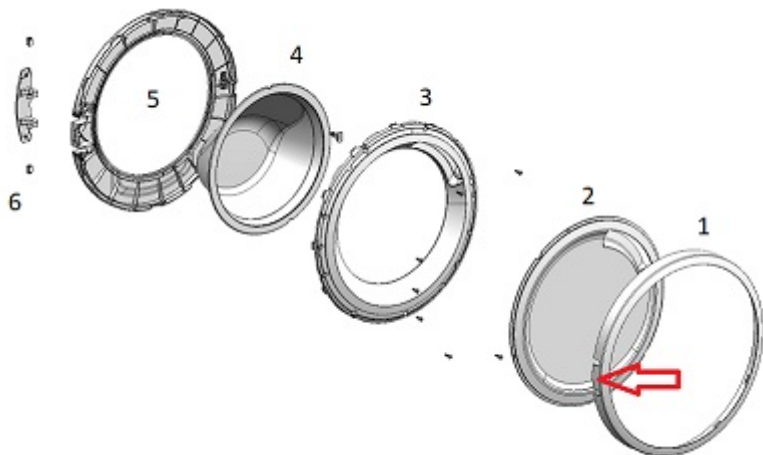

4.5.2 Durelių konstrukcinių dalių uždėjimas

- ▶ Uždėkite atvirkščia eilės tvarka.

4.6 Durelių vyrio keitimas



⚠ PERSPĖJIMAS

Atvira vyrių sritis!

Galima prisispausti / prisiverti pirštus

- ▶ Nekiškite rankų į vyrių sritį.
- ▶ Mūvėkite apsaugines pirštines.

Reikalavimas.

- ✔ Prietaisas atjungtas nuo maitinimo šaltinio.
- ✔ Prietaisas atjungtas nuo vandens tiekimo.

4.6.1 Durelių vyrio nuėmimas

1. Atpalaiduokite du varžtus.
2. Nuimkite dureles.
3. Išardykite dureles nuo išorės vidaus link.

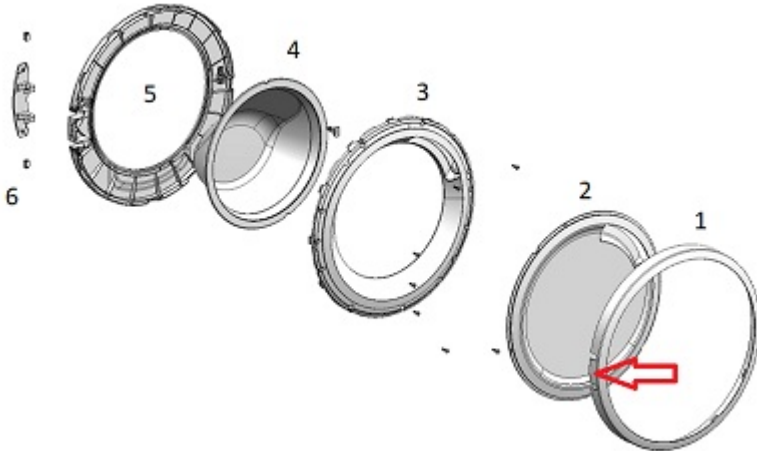



4. Nuimkite durelių vyrį.

4.6.2 Durelių vyrio uždėjimas

- ▶ Uždėkite atvirkščia eilės tvarka.

4.7 Durelių sandariklio keitimas

| | |
|--|---|
|  | ⚠ PERSPĖJIMAS Aštrios korpuso briaunos! Galima įsijauti ▶ Mūvėkite apsaugines pirštines. |
|--|---|

| | |
|--|---|
|  | ⚠ PERSPĖJIMAS Pavojus, kad atpalaidavus varžtus dalys nukris! Krentančios dalys gali sužeisti. ▶ Apsaugokite konstrukcinę dalį, kad ji nenukristų. |
|--|---|

| | |
|--|---|
|  | DĖMESIO! Pavojus, kad atpalaidavus varžtus dalys nukris! Gali būti sugadintos kitos prietaiso dalys arba kliento namai, pvz., grindys. ▶ Apsaugokite konstrukcinę dalį, kad ji nenukristų. |
|--|---|

Reikalavimas.

- ✓ Prietaisas atjungtas nuo maitinimo šaltinio.
- ✓ Prietaisas atjungtas nuo vandens tiekimo.
- ✓ Prietaisai yra laisvai prieinami.
- ✓ [Išimtas skalbiklio stalčius.→303](#)
- ✓ Antjuostė nuimta.
- ✓ [Durelės nuimtos.→305](#)
- ✓ [Apatinis dangtis nuimtas.→313](#)

4.7.1 Durelių sandariklio nuėmimas

1. Atpalaiduokite būgno apšvietimo laikiklį.



2.

| | |
|---|---|
|  | DĖMESIO! Pavojus sugadinti paviršius! Naudojant netinkamus įrankius galima subraižyti prietaiso paviršių. ▶ Norėdami pakeisti veržiamąjį žiedą, naudokite tik plastikinius įrankius. |
|---|---|

Plastikiniu įrankiu nuimkite veržiamąjį žiedą nuo tarpinės.

3. Atpalaiduokite durų sandariklį nuo priekinio skydo.
4. Atjunkite nuo durelių užrakto kabelių jungtį.

5. Nurodyta tvarka atpalaiduokite varžtus.



6. Nuimkite priekinį skydą.

7. Atjunkite visas žarnų jungtis.

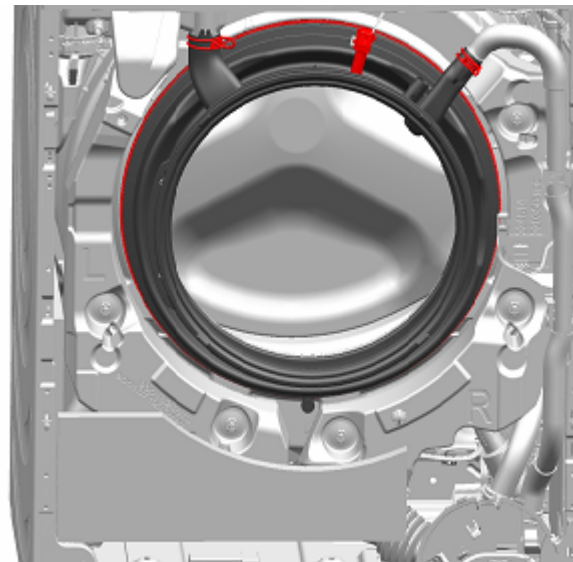

8. Nuimkite durelių sandariklį.

4.7.2 Durelių sandariklio uždėjimas

- ▶ Uždėkite atvirkščia eilės tvarka.

4.8 Durelių užrakto keitimas

Kaip gamintojas, esame įsipareigoję klientams pateikti atsarginį durų užraktą, įskaitant remonto instrukcijas, pagal Reglamentą (ES) 2019/2023. Tačiau norime atkreipti dėmesį, kad pakeitus durų užraktą, prieš pradėdant naudoti prietaisą, kvalifikuotas elektrikas privalo atlikti elektrotechninės saugos bandymą. Šis asmuo turi būti kvalifikuotas pagal šalyje galiojančius įstatymus, reglamentus ir standartus.

| | |
|--|--|
|  | ⚠ PAVOJUS Elektros smūgio pavojus dėl dalių, kuriose yra įtampa! Pavojus gyvybei dėl elektros smūgio netinkamo remonto atveju <ul style="list-style-type: none">▶ Elektrinės dalis remontuoti turi kvalifikuoti elektrikai.▶ Po remonto pasirūpinkite, kad būtų atliktas saugos bandymas pagal VDE 0701 arba šalyje galiojančius reglamentus. |
|--|--|

| | |
|--|--|
|  | ⚠ PERSPĖJIMAS Aštrios korpuso briaunos! Galima įsijauti <ul style="list-style-type: none">▶ Mūvėkite apsaugines pirštines. |
|--|--|

| | |
|--|--|
|  | ⚠ ĮSPĖJIMAS Paverstų prietaisų slydimas! Galimi kaulų lūžiai ir prispaudimai <ul style="list-style-type: none">▶ Apsaugokite prietaisus, kad jie nepaslystų. |
|--|--|

| | |
|---|--|
|  | ⚠ PERSPĖJIMAS Pavojus, kad atpalaidavus varžtus dalys nukris! Krentančios dalys gali sužeisti. <ul style="list-style-type: none">▶ Apsaugokite konstrukcinę dalį, kad ji nenukristų. |
|---|--|

| | |
|--|--|
|  | DĖMESIO! Pavojus, kad atpalaidavus varžtus dalys nukris! Gali būti sugadintos kitos prietaiso dalys arba kliento namai, pvz., grindys. <ul style="list-style-type: none">▶ Apsaugokite konstrukcinę dalį, kad ji nenukristų. |
|--|--|

Reikalavimas.

- ✓ Prietaisas atjungtas nuo maitinimo šaltinio.
- ✓ Prietaisas atjungtas nuo vandens tiekimo.

- ✓ Prietaisai yra laisvai prieinami.
- ✓ Baldinė plokštė nuimta.
- ✓ Antjuostė nuimta.
- ✓ [Durelės nuimtos. → 305](#)
- ✓ Veržiamasis žiedas nuimtas.
- ✓ Priekinis skydas nuimtas.
- ✓ Durelių sandariklis nuimtas.

4.8.1 Durelių užrakto nuėmimas

1. Atjunkite durelių užrakto kištuką.
2. Atpalaiduokite durelių užraktą.



3. Nuimkite durelių užraktą.

4.8.2 Durelių užrakto sumontavimas

Kad būtų užtikrinta prietaiso avarinio durelių atidarymo funkcija, durelių užraktas turi būti teisingoje padėtyje.

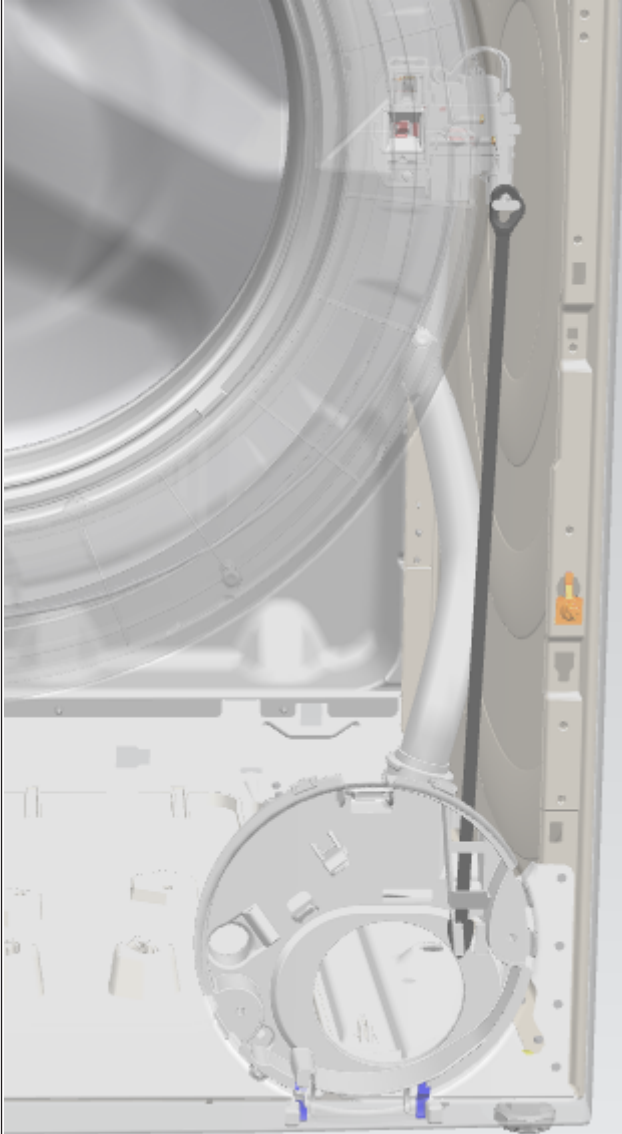

- ▶ Uždėkite atvirkščia eilės tvarka.

4.9 Būgno apšvietimo keitimas



⚠ PERSPĖJIMAS

Aštrios korpuso briaunos!

Galima įsipjauti

- ▶ Mūvėkite apsaugines pirštines.



⚠ ĮSPĖJIMAS

Paverstų prietaisų slydimas!

Galimi kaulų lūžiai ir prispaudimai

- ▶ Apsaugokite prietaisus, kad jie nepaslystų.



⚠ PERSPĖJIMAS

Pavojus, kad atpalaidavus varžtus dalys nukris!

Krentančios dalys gali sužeisti.

- ▶ Apsaugokite konstrukcinę dalį, kad ji nenukristų.



DĖMESIO!

Pavojus, kad atpalaidavus varžtus dalys nukris!

Gali būti sugadintos kitos prietaiso dalys arba kliento namai, pvz., grindys.

- ▶ Apsaugokite konstrukcinę dalį, kad ji nenukristų.

Reikalavimas.

- ✔ Prietaisas atjungtas nuo maitinimo šaltinio.
- ✔ Prietaisas atjungtas nuo vandens tiekimo.
- ✔ Prietaisai yra laisvai prieinami.
- ✔ [Išimtas skalbiklio stalčius.→303](#)
- ✔ Antjuostė nuimta.

4.9.1 Būgno apšvietimo nuėmimas

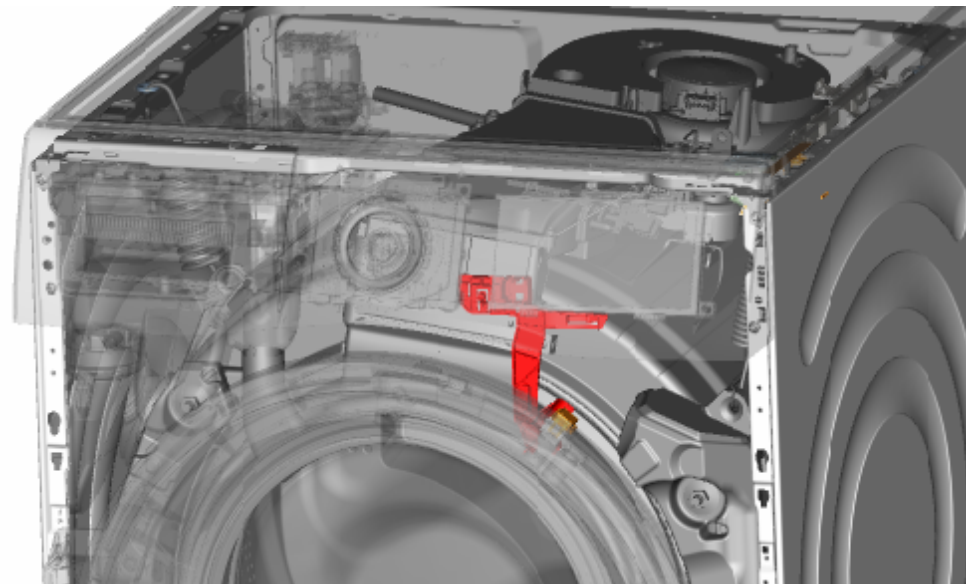

1. Ištraukite būgno apšvietimo laikiklį iš prietaiso.
2. Atjunkite elektros jungtis.
3. Nuimkite būgno apšvietimą nuo apšvietimo laikiklio.

4.9.2 Būgno apšvietimo sumontavimas

- ▶ Uždėkite atvirkščia eilės tvarka.

4.10 Apatinio dangčio keitimas



Pav. 1: Apatinės grupės dangtis

Reikalavimas.

- ✔ Prietaisas atjungtas nuo maitinimo šaltinio.
- ✔ Prietaisas atjungtas nuo vandens tiekimo.
- ✔ Baldinė plokštė nuimta.

4.10.1 Apatinio dangčio nuėmimas

Reikalavimas.

- ✔ Prietaisas atjungtas nuo maitinimo šaltinio.
- ✔ Prietaisas atjungtas nuo vandens tiekimo.

1. Nuimkite apatinį dangtį.

2. Nuimkite žarną nuo laikiklio.

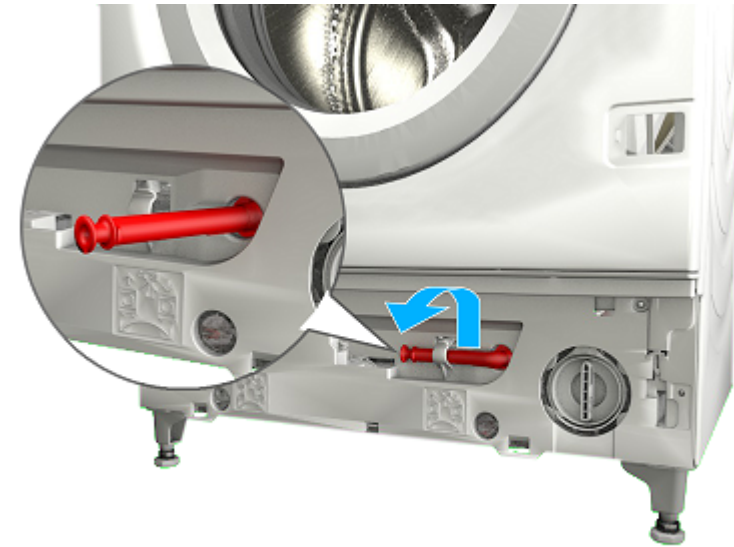

Remontas

3. 1. Išsukite varžtą (1).
2. Paspauskite fiksavimo tašką ir nuimkite žemyn (2).

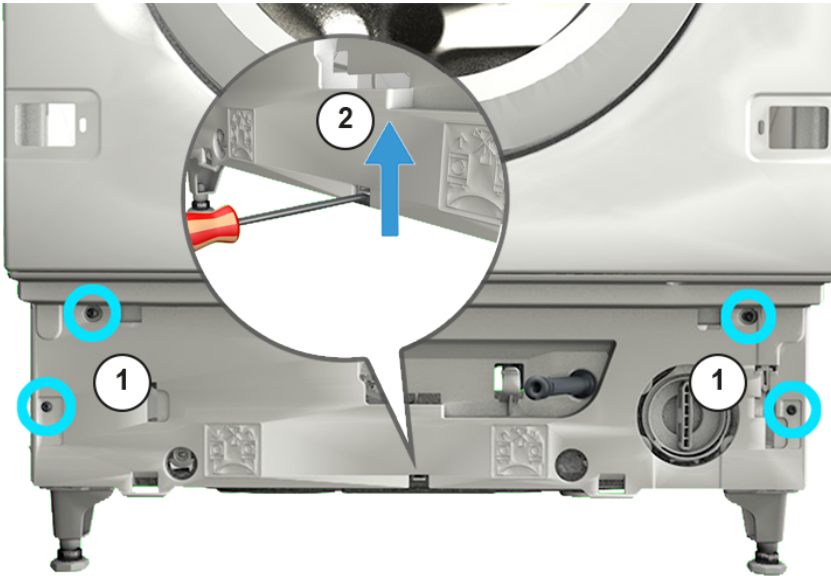

4. Patraukite apatinės grupės dangtį ir nuimkite jį pirmyn.

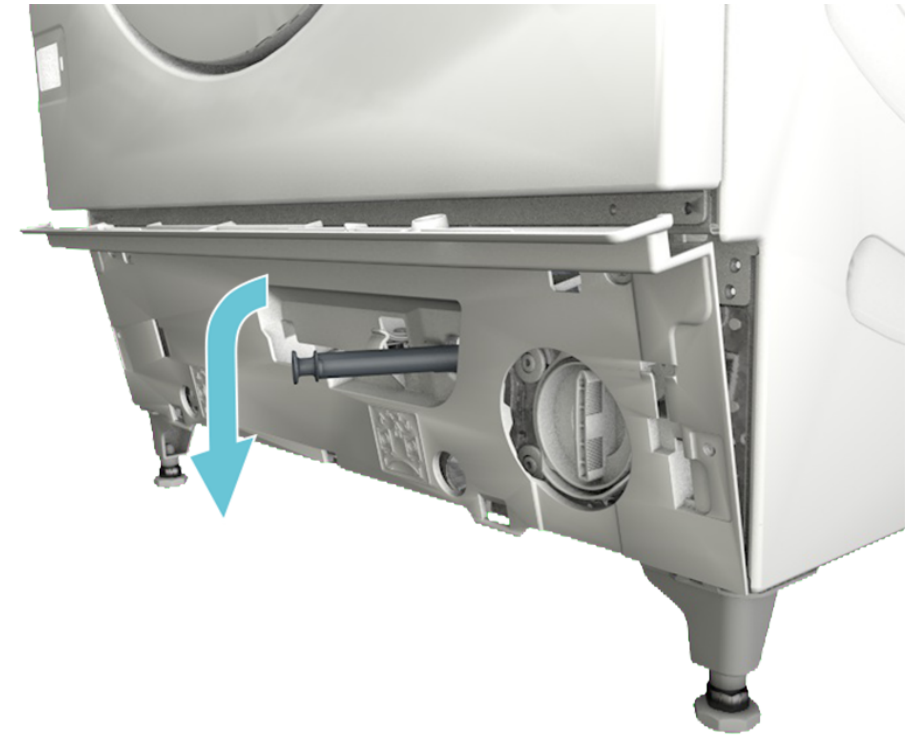

5. Ištraukite iš dangčio žarną.

4.10.2 Dangčio uždėjimas

- Uždėkite atvirkščia eilės tvarka.

4.11 Priekinio skydo keitimas



⚠ PERSPĖJIMAS

Aštrios korpuso briaunos!

Galima įsijauti

- ▶ Mūvėkite apsaugines pirštines.

Reikalavimas.

- ✔ Prietaisas atjungtas nuo maitinimo šaltinio.
- ✔ Prietaisas atjungtas nuo vandens tiekimo.
- ✔ Prietaisai yra laisvai prieinami.
- ✔ Išimtas skalbiklio stalčius. → 303
- ✔ Baldinė plokštė nuimta.
- ✔ Durelės nuimtos. → 305
- ✔ Durelių sandariklis nuimtas.

4.11.1 Priekinio skydo nuėmimas

1. Atpalaiduokite būgno apšvietimo laikiklį.

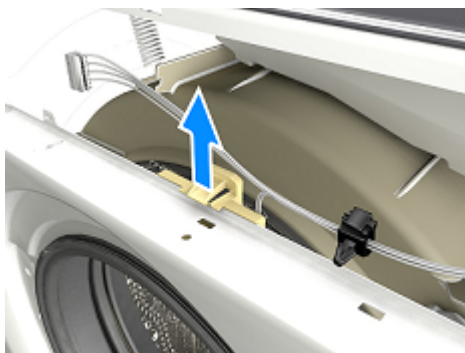

2.



⚠ PERSPĖJIMAS

Pavojus, kad atpalaidavus varžtus dalys nukris!

Krentančios dalys gali sužeisti.

- ▶ Apsaugokite konstrukcinę dalį, kad ji nenukristų.



DĖMESIO!

Pavojus, kad atpalaidavus varžtus dalys nukris!

Gali būti sugadintos kitos prietaiso dalys arba kliento namai, pvz., grindys.

- ▶ Apsaugokite konstrukcinę dalį, kad ji nenukristų.

Nurodyta tvarka atpalaiduokite varžtus.



3. Nuimkite priekinį skydą.

4.11.2 Priekinio skydo uždėjimas

- ▶ Uždėkite atvirkščia eilės tvarka.

Reparasjonstips - Vaskemaskin

| | |
|---|------------|
|  Om dette dokumentet | 318 |
| 1.1 Viktig informasjon | 318 |
| 1.1.1 Formål..... | 318 |
| 1.2 Forklaring av symboler..... | 318 |
| 1.2.1 Farenivåer | 318 |
| 1.2.2 Faresymboler..... | 318 |
| 1.2.3 Advarslenes struktur | 319 |
| 1.2.4 Generelle symboler | 319 |
|  Sikkerhet | 320 |
| 2.1 Generelle sikkerhetsinstruksjoner | 320 |
| 2.1.1 Alle husholdningsapparater | 320 |
|  Verktøy og hjelpemidler | 321 |
|  Reparasjon | 322 |
| 4.1 Utskiftning av instrumentpanel..... | 322 |
| 4.1.1 Demontering av instrumentpanel..... | 322 |
| 4.1.2 Montering av instrumentpanel | 323 |
| 4.2 Utskiftning av vaskemiddelskuff..... | 324 |
| 4.2.1 Demontering av vaskemiddelskuff..... | 324 |
| 4.2.2 Montering av vaskemiddelskuff | 324 |
| 4.3 Utskiftning av håndtak på vaskemiddelskuff | 325 |
| 4.3.1 Demontering av håndtak på vaskemiddelskuff | 325 |
| 4.3.2 Montering av håndtak på vaskemiddelskuff..... | 325 |
| 4.4 Utskiftning av dør | 326 |
| 4.4.1 Demontering av dør | 326 |
| 4.4.2 Montering av dør..... | 326 |
| 4.5 Utskiftning av dørkomponenter | 327 |
| 4.5.1 Demontering av dørkomponenter | 327 |
| 4.5.2 Montering av dørkomponenter | 327 |
| 4.6 Utskiftning av dørhengsel..... | 328 |
| 4.6.1 Demontering av dørhengsel..... | 328 |
| 4.6.2 Montering av dørhengsel | 328 |
| 4.7 Utskiftning av dørpakning..... | 329 |
| 4.7.1 Demontering av dørpakning..... | 329 |
| 4.7.2 Montering av dørpakning | 330 |

| | |
|--|-----|
| 4.8 Utskiftning av dørlås..... | 331 |
| 4.8.1 Demontering av dørlås..... | 331 |
| 4.8.2 Montering av dørlås | 332 |
| 4.9 Utskiftning av lampe i trommel | 333 |
| 4.9.1 Demontering av lampe i trommel | 333 |
| 4.9.2 Montering av lampe i trommel | 333 |
| 4.10 Utskiftning av nedre deksel..... | 334 |
| 4.10.1 Demontering av nedre deksel..... | 334 |
| 4.10.2 Montering av deksel..... | 335 |
| 4.11 Utskiftning av frontpanel | 336 |
| 4.11.1 Demontering av frontpanel | 336 |
| 4.11.2 Montering av frontpanel | 337 |

i Om dette dokumentet

1.1 Viktig informasjon

1.1.1 Formål

Disse tipsene om reparasjon skal hjelpe kunden til selv å kunne reparere apparater i samsvar med gjeldende regulering av øko-design (med gyldighet 03/2021).





De inneholder informasjon om hvordan definerte reservedeler skiftes, inklusive advarsler og risikoer.

Kontakt vår kundeservice dersom du har spørsmål. Vi påtar oss kun ansvar for skader dersom tipsene om reparasjon er korrekt fulgt.

1.2 Forklaring av symboler

1.2.1 Farenivåer

Advarslene som viser farenivå, består av et symbol og et signalord. Signalordet viser hvor alvorlig faren er.





| Advarsel som viser farenivå | Betydning |
|---|---|
|  | Dersom advarselen ignoreres, vil det føre til død eller alvorlige personskader. |
|  | Dersom advarselen ignoreres, kan det føre til død eller alvorlige personskader. |
|  | Dersom advarselen ignoreres, kan det føre til mindre personskader. |
|  | Dersom advarselen ignoreres, kan det føre til materiell skade. |

Tabell 1: Farenivåer



1.2.2 Faresymboler

Faresymboler er symbolske fremstillinger som gir en indikasjon av hvilken type fare det dreier seg om.

Følgende faresymboler brukes i dette dokumentet:

| Faresymbol | Betydning |
|---|-------------------------|
|  | Generell advarsel |
|  | Fare for elektrisk støt |
|  | Eksplisjonsfare |
|  | Fare for å skjære seg |
|  | Klemfare |



i Om dette dokumentet

| Faresymbol | Betydning |
|--|------------------------------------|
|  | Fare på grunn av varme overflater |
|  | Fare på grunn av sterkt magnetfelt |
|  | Fare fra ikke-ioniserende stråling |



Tabell 2: Faresymboler

1.2.3 Advarslenes struktur

Advarslene i dette dokumentet har standardisert utseende og standardisert struktur.



| | |
|--|--|
|  | <div style="background-color: red; color: white; padding: 2px; text-align: center;">  FARE </div> <p>Faretype og kilde til fare! Mulige konsekvenser dersom fare/advarsel ignoreres.</p> <ul style="list-style-type: none"> ▶ Tiltak og forbud for å forebygge fare. |
|--|--|





Eksemplet nedenfor viser en advarsel mot elektrisk støt på grunn av strømførende deler. Tiltaket for å unngå faren er angitt.

| | |
|---|--|
|  | <div style="background-color: red; color: white; padding: 2px; text-align: center;">  FARE </div> <p>Fare for elektrisk støt på grunn av strømførende deler! Død på grunn av drepende elektrisk støt</p> <ul style="list-style-type: none"> ▶ Koble apparatene fra strømforsyningen i minst 60 sekunder før reparasjonene startes. |
|---|--|

1.2.4 Generelle symboler

Følgende generelle symboler brukes i dette dokumentet:

| Gen. symbol | Betydning |
|--|---|
|  | Identifisering av et spesielt tips (tekst og/eller grafikk) |
|  | Identifisering av et enkelt tips (kun tekst) |
|  | Identifisering av en lenke til en opplæringsvideo |

| Gen. symbol | Betydning |
|---|---|
|  | Identifisering av nødvendig verktøy |
|  | Identifisering av nødvendige forutsetninger |
|  | Identifisering av en betingelse (hvis ..., så ...) |
|  | Identifisering av et resultat |
| [Start] | Identifisering av en tast eller knapp |
| [00123456] | Identifisering av et materialnummer |
| Status | Identifisering av vist tekst/vindu (i apparatets display) |

Tabell 3: Generelle symboler

2.1 Generelle sikkerhetsinstruksjoner

2.1.1 Alle husholdningsapparater

Fare for elektrisk støt på grunn av strømførende deler!

- Feil ved reparasjoner hvor elektriske komponenter er involvert, kan føre til elektrisk støt!
- Koble apparatet fra strømmettet i minst 60 sekunder før arbeidet startes.
- Etter reparasjonen må du sørge for at det utføres en sikkerhetstest iht. VDE 0701 eller gjeldende forskrifter i det respektive land.

Fare for personskade på grunn av skarpe kanter!

- Bruk vernehansker.

Fare for å knuse legemsdeler under reparasjoner, vedlikehold, feilsøking og service på grunn av tunge og bevegelige komponenter

- Bruk vernesko.
- Sikre tunge komponenter for å hindre at de faller ned.
- Ikke stikk kroppsdelene inn i bevegelige komponenter.







Fare for apparatets sikkerhet/funksjon!





- Bruk kun originale reservedeler.

Fare for skade på deler som er følsomme overfor elektrostatisk utlading (ESD)!

- Ikke berør modulene, inklusive tilkoblinger og ledere.

Verktøy og hjelpemidler

| Betegnelse | Detaljer | Bilder |
|---|--|--|
| Hjelpeverktøy [15000155] | Verktøy for å løsne plastdeler |  |
| Torx T20-skrutrekker med borehull [00340764] | 100 mm, for skruer med splint |  |
| Momentnøkkel [15000441] | Momentnøkkel 20 - 100 Nm | |
| Flat skrutrekker [00340854] | Blad 3,5 mm x 0,6 mm x 100 mm, beskyttende isolasjon 1000 V AC |  |
| Flat skrutrekker [00340855] | Blad 5,5 mm x 1,0 mm x 125 mm, beskyttende isolasjon 1000 V AC |  |
| Spisstang, vinkelmonster [00341269] | Lengde 200 mm |  |
| Avbitertang [00342182] | Lengde: 200 mm |  |

| Betegnelse | Detaljer | Bilder |
|----------------------------------|------------------------------------|---|
| Fastnøkkel [00340811] | Størrelse på fastnøkkel 10°mm, M6 |  |
| Combination wrench [00340814] | Størrelse på fastnøkkel 13°mm, M8 |  |
| Fastnøkkel [00340817] | Størrelse på fastnøkkel 17 mm, M10 |  |
| Fastnøkkel [15000459] | Størrelse på fastnøkkel 16°mm, M10 |  |

4.1 Utskiftning av instrumentpanel

| | |
|--|--|
|  | ⚠ FORSIKTIG Skarpe kanter på hus! Kuttskader ▶ Bruk vernehansker. |
|--|--|

| | |
|--|---|
|  | ⚠ ADVARSEL Tiltede apparater kan skli ut! Beinbrudd/klemskader ▶ Sikre apparatene mot å skli ut. |
|--|---|

| | |
|--|---|
|  | ⚠ FORSIKTIG Fare for at deler kan falle ned på grunn av løsnede skruer! Personskade på grunn av fallende deler. ▶ Sikre komponenten så den ikke kan falle ned. |
|--|---|

| | |
|--|---|
|  | OBS! Fare for at deler kan falle ned på grunn av løsnede skruer! Skade på andre deler på apparatet eller i kundens hjem, f.eks. gulv. ▶ Sikre komponenten så den ikke kan falle ned. |
|--|---|

Forutsetning:

- ✔ Apparatet kobles fra strømforsyningen.
- ✔ Apparatet kobles fra vannforsyningen.
- ✔ Apparatet er fritt tilgjengelig.
- ✔ [Vaskemiddelskuffen er tatt ut. → 324](#)

4.1.1 Demontering av instrumentpanel

1. Løsne låselementet (1).
2. Ta av dekslet (2).

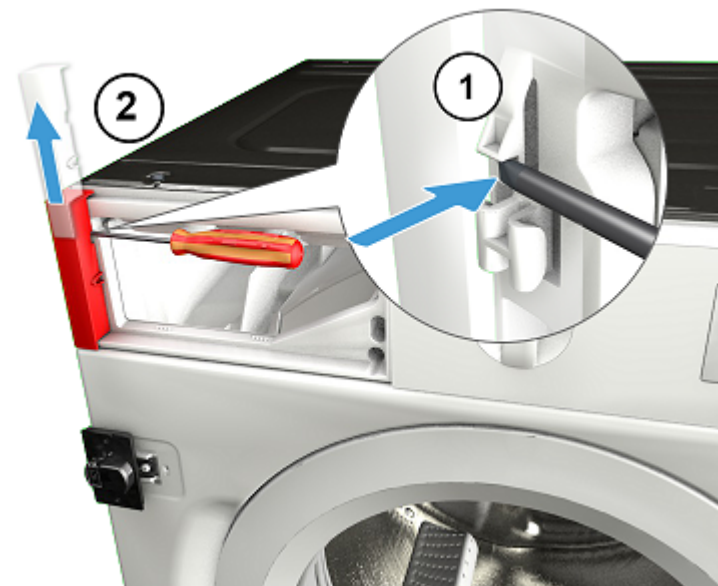

Reparasjon

2. Fjern skruene.



3. 1. Løsne låselementene (1, 2).
2. Trekk instrumentpanelet mot forsiden (3).

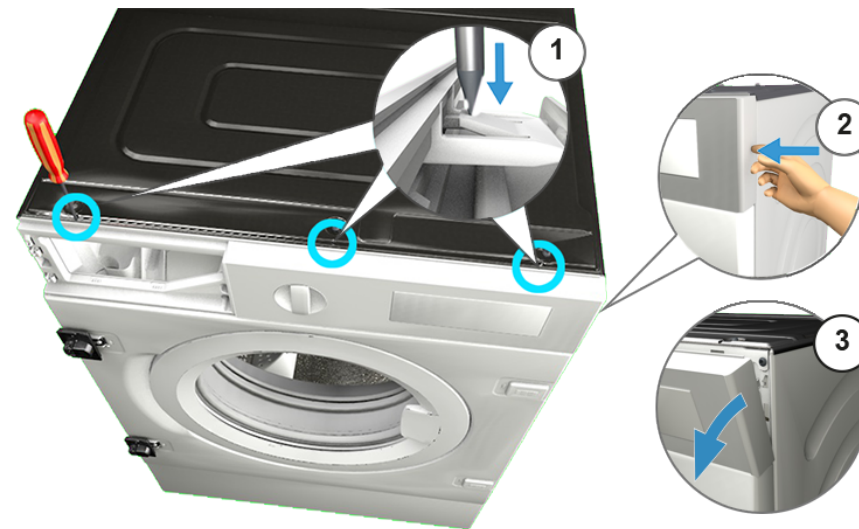

4. Demonter instrumentpanelet.

4.1.2 Montering av instrumentpanel

► Monteres i motsatt rekkefølge.

4.2 Utskiftning av vaskemiddelskuff

Forutsetning:

- ✓ Apparatet kobles fra strømforsyningen.
- ✓ Apparatet kobles fra vannforsyningen.

4.2.1 Demontering av vaskemiddelskuff

1. Trekk ut vaskemiddelskuffen.
2. 1. Trykk innsatsen ned (1).
2. Ta ut vaskemiddelskuffen (2).

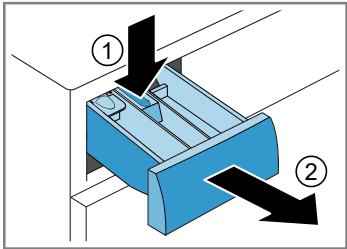

4.2.2 Montering av vaskemiddelskuff

- ▶ Monteres i motsatt rekkefølge.

4.3 Utskiftning av håndtak på vaskemiddelskuff

Forutsetning:

- ✓ Apparatet kobles fra strømforsyningen.
- ✓ Apparatet kobles fra vannforsyningen.
- ✓ [Vaskemiddelskuffen er tatt ut. →324](#)

4.3.1 Demontering av håndtak på vaskemiddelskuff

1. Løsne låselementene.

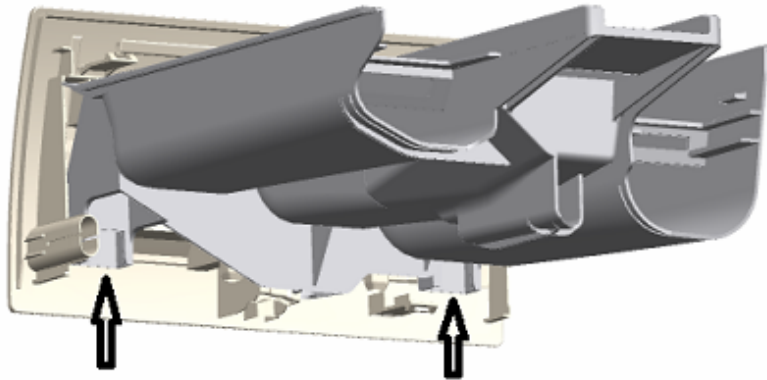

2. Demonter håndtaket på vaskemiddelskuffen.

4.3.2 Montering av håndtak på vaskemiddelskuff

- ▶ Monteres i motsatt rekkefølge.

4.4 Utskiftning av dør



⚠️ FORSIKTIG

Åpent hengsleområde!

- Fare for å knuse/sette fast fingre
- ▶ Ikke grip inn i hengsleområdet.
 - ▶ Bruk vernehansker.

Forutsetning:

- ✔ Apparatet kobles fra strømforsyningen.
- ✔ Apparatet kobles fra vannforsyningen.
- ✔ Døren er åpen.
- ✔ Møbelfronten er fjernet.

4.4.1 Demontering av dør

1.



OBS!

- Fare for at deler kan falle ned på grunn av løsnede skruer!**
Skade på andre deler på apparatet eller i kundens hjem, f.eks. gulv.
- ▶ Sikre komponenten så den ikke kan falle ned.



⚠️ FORSIKTIG

- Fare for at deler kan falle ned på grunn av løsnede skruer!**
Personskade på grunn av fallende deler.
- ▶ Sikre komponenten så den ikke kan falle ned.

Fjern skruene (1).

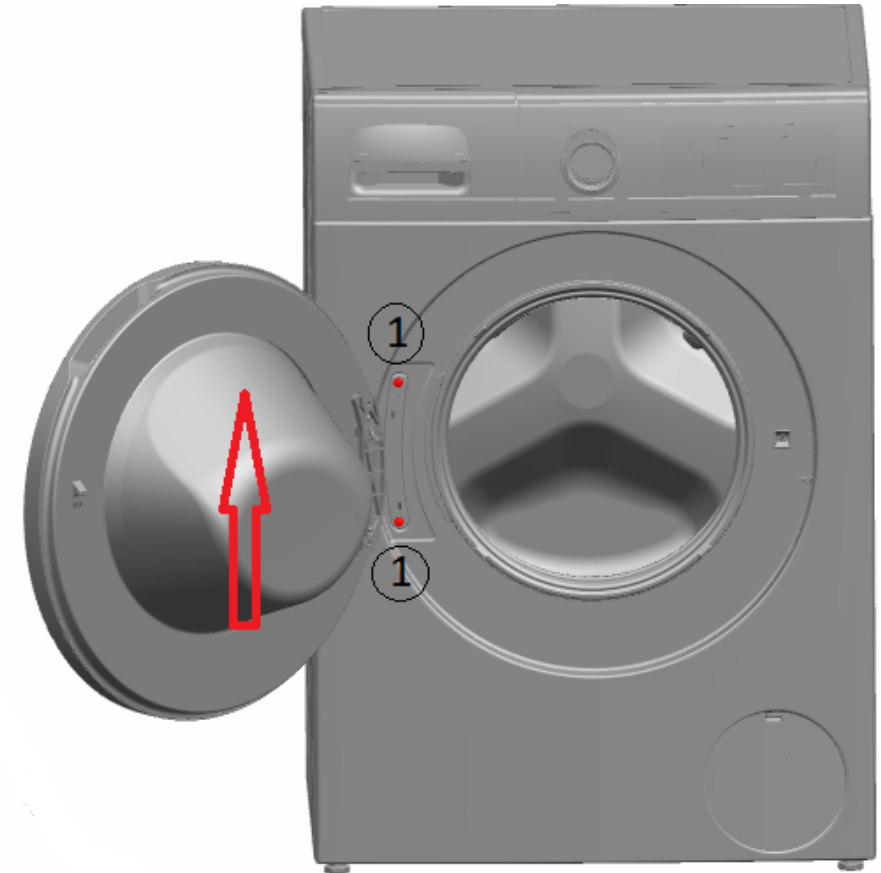

2. Ta ut døren mot oppsiden.

4.4.2 Montering av dør

- ▶ Monteres i motsatt rekkefølge.

4.5 Utskiftning av dørkomponenter



⚠ FORSIKTIG

Åpent hengsleområde!

Fare for å knuse/sette fast fingre

- ▶ Ikke grip inn i hengsleområdet.
- ▶ Bruk vernehansker.

Forutsetning:

- ✓ Apparatet kobles fra strømforsyningen.
- ✓ Apparatet kobles fra vannforsyningen.
- ✓ Møbelfronten er fjernet.
- ✓ [Døren er demontert.](#)→326

4.5.1 Demontering av dørkomponenter

- ▶ Ta døren fra hverandre fra utsiden til innsiden.

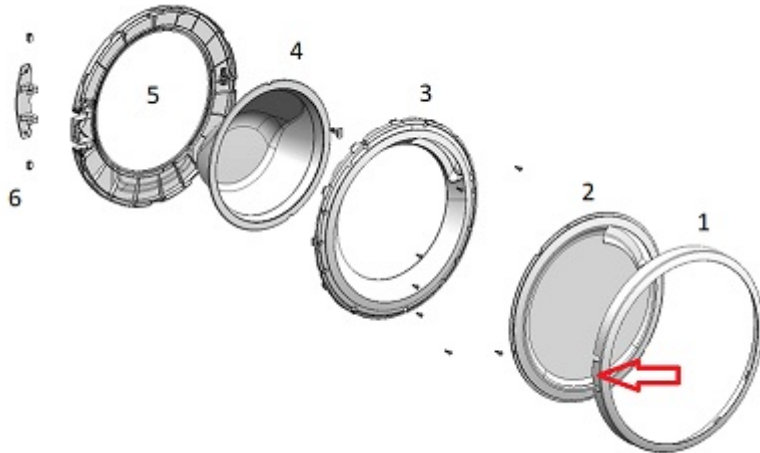

4.5.2 Montering av dørkomponenter

- ▶ Monteres i motsatt rekkefølge.

4.6 Utskiftning av dørhengsel



⚠ FORSIKTIG

Åpent hengsleområde!

Fare for å knuse/sette fast fingre

- ▶ Ikke grip inn i hengsleområdet.
- ▶ Bruk vernehansker.

Forutsetning:

- ✔ Apparatet kobles fra strømforsyningen.
- ✔ Apparatet kobles fra vannforsyningen.

4.6.1 Demontering av dørhengsel

1. Løsne to skruer.
2. Demonter døren.
3. Ta døren fra hverandre fra utsiden til innsiden.

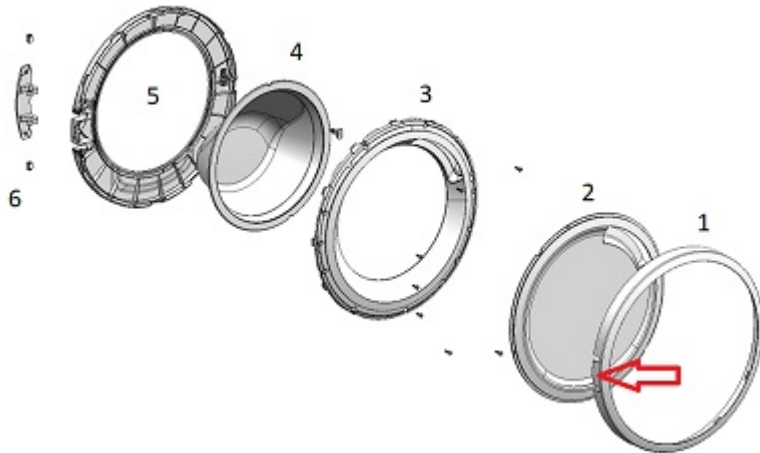



4. Demonter dørhengslen.

4.6.2 Montering av dørhengsel

- ▶ Monteres i motsatt rekkefølge.

4.7 Utskiftning av dørpakning

| | |
|--|--|
|  | ⚠ FORSIKTIG Skarpe kanter på hus! Kuttskader ▶ Bruk vernehansker. |
|--|--|

| | |
|--|---|
|  | ⚠ FORSIKTIG Fare for at deler kan falle ned på grunn av løsnede skruer! Personskade på grunn av fallende deler. ▶ Sikre komponenten så den ikke kan falle ned. |
|--|---|

| | |
|--|---|
|  | OBS! Fare for at deler kan falle ned på grunn av løsnede skruer! Skade på andre deler på apparatet eller i kundens hjem, f.eks. gulv. ▶ Sikre komponenten så den ikke kan falle ned. |
|--|---|

Forutsetning:

- ✔ Apparatet kobles fra strømforsyningen.
- ✔ Apparatet kobles fra vannforsyningen.
- ✔ Apparatet er fritt tilgjengelig.
- ✔ [Vaskemiddelskuffen er tatt ut.→324](#)
- ✔ Instrumentpanelet er demontert.
- ✔ [Døren er demontert.→326](#)
- ✔ [Nedre deksel er demontert.→334](#)

4.7.1 Demontering av dørpakning

1. Løsne holderen på trommellampen.



2.

| | |
|---|--|
|  | OBS! Fare for skader på overflaten! Apparatets overflate kan få riper ved bruk av feil verktøy. ▶ Bruk bare plastverktøy når du skal skifte ut strammeringen. |
|---|--|

Fjern strammeringen fra pakningen med et plastverktøy.

3. Løsne dørpakningen fra frontpanelet.
4. Løsne kabelkontakten fra dørlåsen.

Reparasjon

5. Løsne skruene i vist rekkefølge.



6. Demonter frontpanelet.

7. Koble fra alle slangekoblingene.

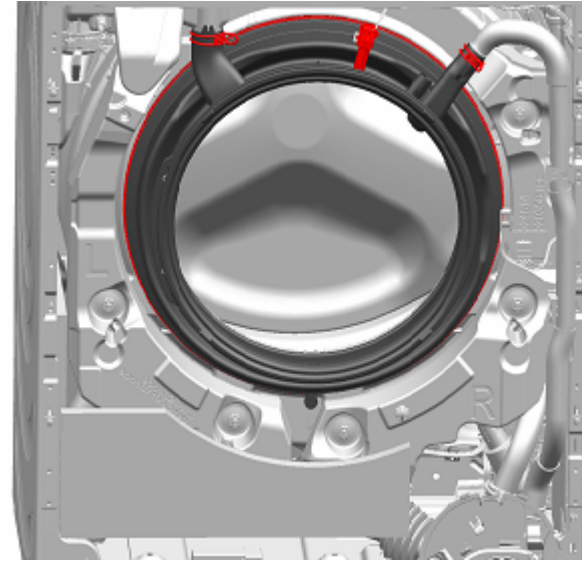





8. Demonter dørpakningen.

4.7.2 Montering av dørpakning

► Monteres i motsatt rekkefølge.

4.8 Utskiftning av dørlås

Egenskap av produsent er vi forpliktet til å stille til rådighet for forbrukerne reserve- delen dørlås inkl. reparasjonsveiledning i samsvar med direktiv (EU) 2019/2023. Men vi vil gjøre oppmerksom på at det etter utskiftning av en dørlås må utføres en elektroteknisk sikkerhetstest av en kvalifisert elektriker før apparatet tas i bruk. Denne personen må kunne dokumentere at hun/han er kvalifisert i henhold til gjeldende lover, forskrifter og standarder i det respektive land.

| | |
|--|--|
|  | <p>FARE</p> <p>Fare for elektrisk støt på grunn av strømførende deler! Livsfare på grunn av elektrisk støt ved feil reparasjon</p> <ul style="list-style-type: none">▶ Elektriske deler skal repareres av kvalifiserte elektrikere.▶ Etter reparasjonen må du sørge for at det utføres en sikkerhets- test iht. VDE 0701 eller gjeldende forskrifter i det respektive land. |
|  | <p>FORSIKTIG</p> <p>Skarpe kanter på hus! Kuttskader</p> <ul style="list-style-type: none">▶ Bruk vernehansker. |
|  | <p>ADVARSEL</p> <p>Tiltede apparater kan skli ut! Beinbrudd/klemskader</p> <ul style="list-style-type: none">▶ Sikre apparatene mot å skli ut. |
|  | <p>FORSIKTIG</p> <p>Fare for at deler kan falle ned på grunn av løsnede skruer! Personskade på grunn av fallende deler.</p> <ul style="list-style-type: none">▶ Sikre komponenten så den ikke kan falle ned. |
|  | <p>OBS!</p> <p>Fare for at deler kan falle ned på grunn av løsnede skruer! Skade på andre deler på apparatet eller i kundens hjem, f.eks. gulv.</p> <ul style="list-style-type: none">▶ Sikre komponenten så den ikke kan falle ned. |

Forutsetning:

- ✓ Apparatet kobles fra strømforsyningen.
- ✓ Apparatet kobles fra vannforsyningen.

- ✓ Apparatet er fritt tilgjengelig.
- ✓ Møbelfronten er fjernet.
- ✓ Instrumentpanelet er demontert.
- ✓ [Døren er demontert. → 326](#)
- ✓ Stramringen er demontert.
- ✓ Frontpanelet er demontert.
- ✓ Dørpakningen er demontert.

4.8.1 Demontering av dørlås

1. Koble fra dørens låseplugg.
2. Løsne dørlåsen.



3. Demonter dørlåsen.

4.8.2 Montering av dørlås

Dørlåsen må være i korrekt posisjon for å sikre nødfunksjonen for åpning av døren på apparatet.

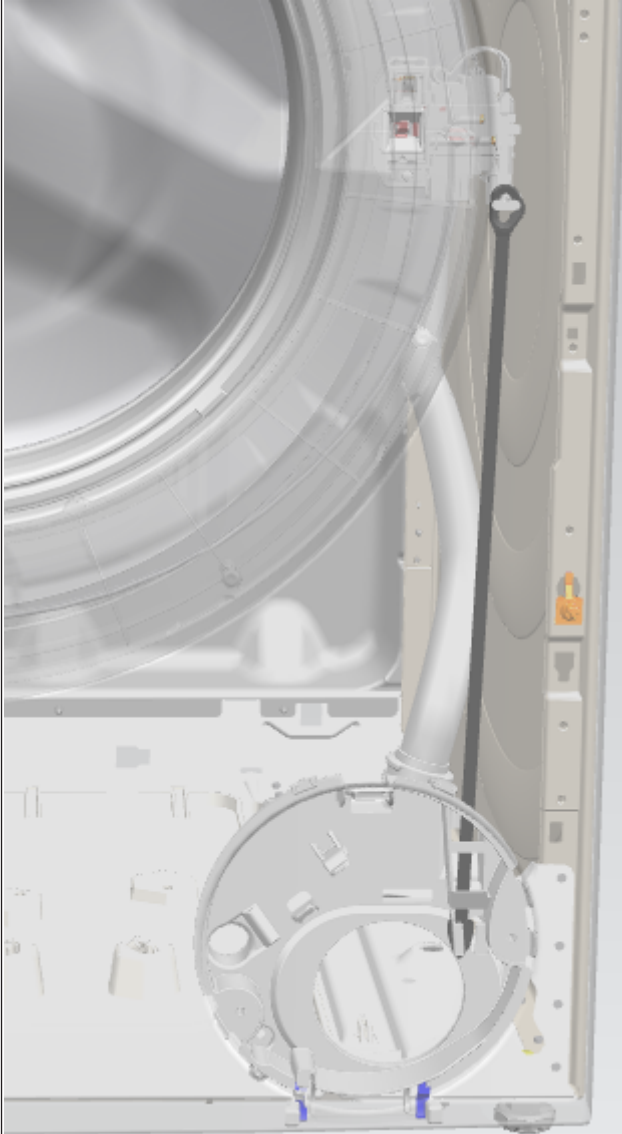

- ▶ Monteres i motsatt rekkefølge.

4.9 Utskiftning av lampe i trommel



⚠️ FORSIKTIG

Skarpe kanter på hus!
Kuttskader
▶ Bruk vernehansker.



⚠️ ADVARSEL

Tiltede apparater kan skli ut!
Beinbrudd/klemskader
▶ Sikre apparatene mot å skli ut.



⚠️ FORSIKTIG

Fare for at deler kan falle ned på grunn av løsnede skruer!
Personskade på grunn av fallende deler.
▶ Sikre komponenten så den ikke kan falle ned.



OBS!

Fare for at deler kan falle ned på grunn av løsnede skruer!
Skade på andre deler på apparatet eller i kundens hjem, f.eks. gulv.
▶ Sikre komponenten så den ikke kan falle ned.

Forutsetning:

- ✔️ Apparatet kobles fra strømforsyningen.
- ✔️ Apparatet kobles fra vannforsyningen.
- ✔️ Apparatet er fritt tilgjengelig.
- ✔️ [Vaskemiddelskuffen er tatt ut. → 324](#)
- ✔️ Instrumentpanelet er demontert.

4.9.1 Demontering av lampe i trommel

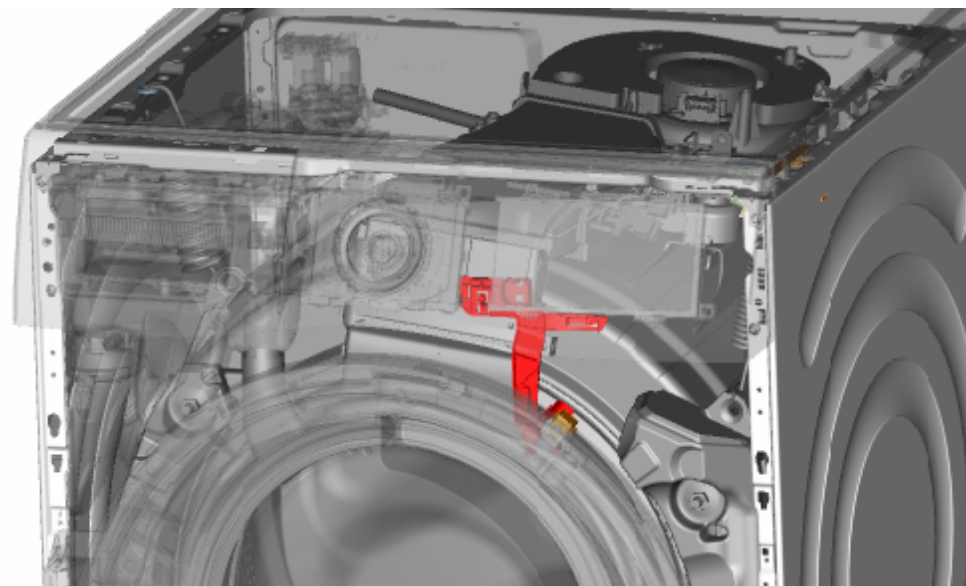

1. Trekk trommellampeholderen ut av apparatet.
2. Koble fra de elektriske tilkoblingene.
3. Demonter trommellampen fra trommellampeholderen.

4.9.2 Montering av lampe i trommel

- ▶ Monteres i motsatt rekkefølge.

4.10 Utskiftning av nedre deksel



Bilde 1: Nedre gruppedeksel

Forutsetning:

- ✓ Apparatet kobles fra strømforsyningen.
- ✓ Apparatet kobles fra vannforsyningen.
- ✓ Møbelfronten er fjernet.

4.10.1 Demontering av nedre deksel

Forutsetning:

- ✓ Apparatet kobles fra strømforsyningen.
 - ✓ Apparatet kobles fra vannforsyningen.
1. Demonter nedre deksel.

2. Løsne slangen fra holderen.

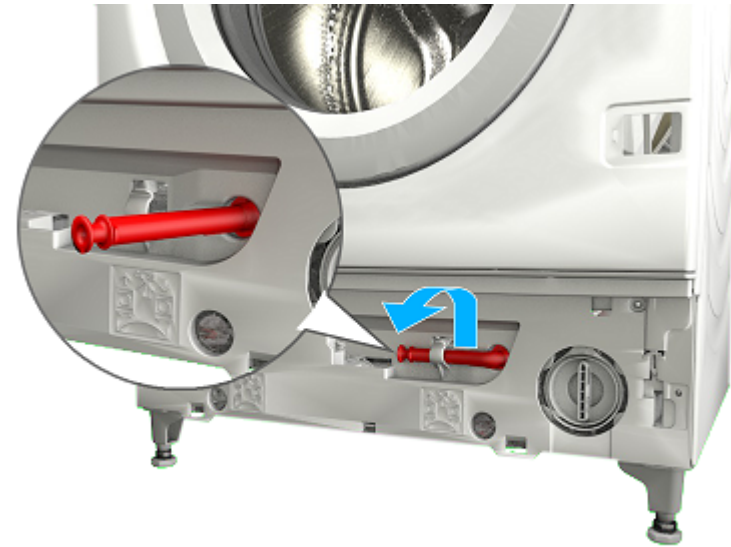

🔧 Reparasjon

3. 1. Skru ut skruen (1).
2. Trykk inn holdepunktet og demonter det mot undersiden (2).

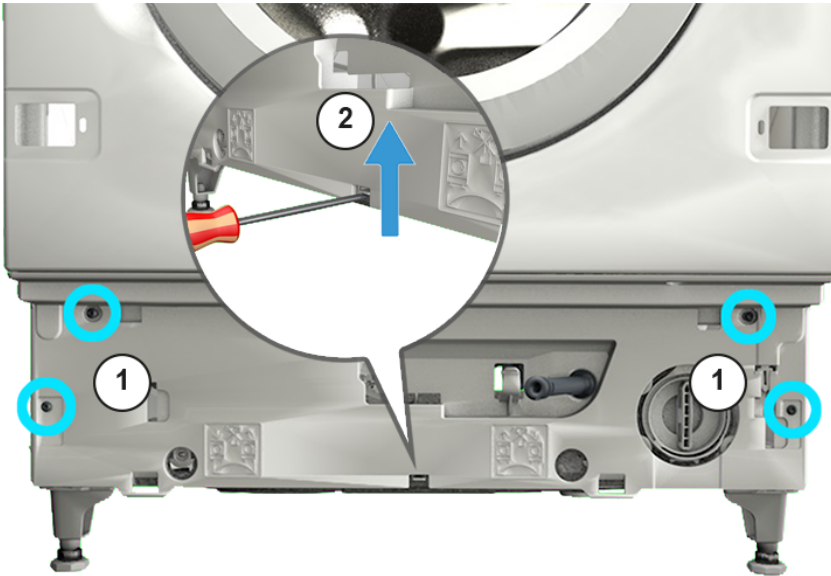

4. Trekk i nedre gruppedeksel og demonter det mot forsiden.

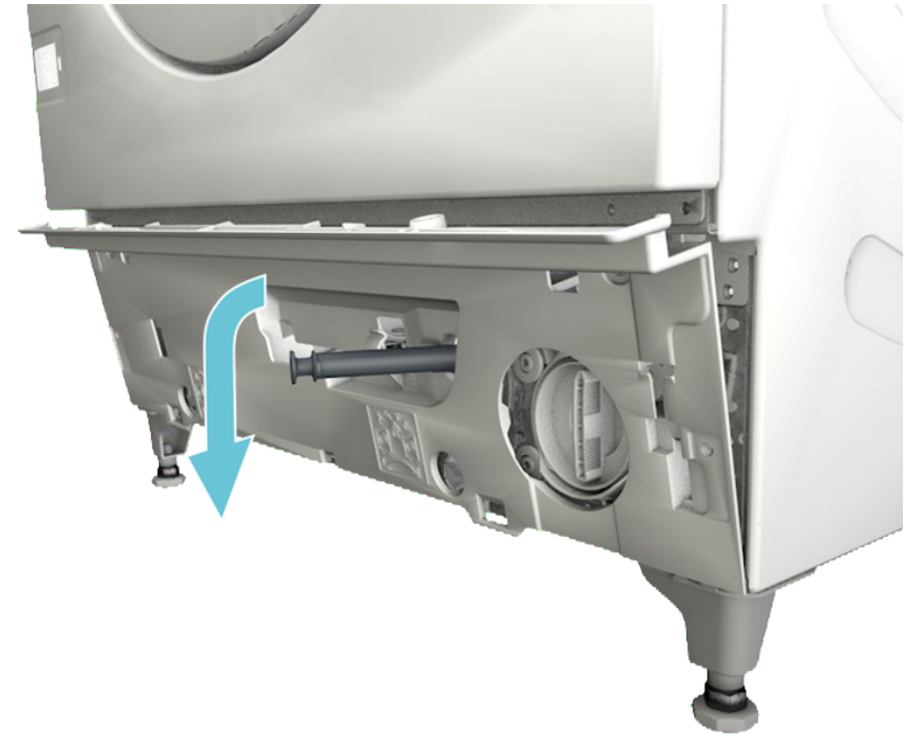

5. Trekk slangen ut av dekslet.

4.10.2 Montering av deksel

- ▶ Monteres i motsatt rekkefølge.

4.11 Utskiftning av frontpanel



⚠️ FORSIKTIG

Skarpe kanter på hus!
Kuttskader
▶ Bruk vernehansker.

Forutsetning:

- ✓ Apparatet kobles fra strømforsyningen.
- ✓ Apparatet kobles fra vannforsyningen.
- ✓ Apparatet er fritt tilgjengelig.
- ✓ [Vaskemiddelskuffen er tatt ut.→324](#)
- ✓ Møbelfronten er fjernet.
- ✓ [Døren er demontert.→326](#)
- ✓ Dørpakningen er demontert.

4.11.1 Demontering av frontpanel

1. Løsne holderen på trommellampen.

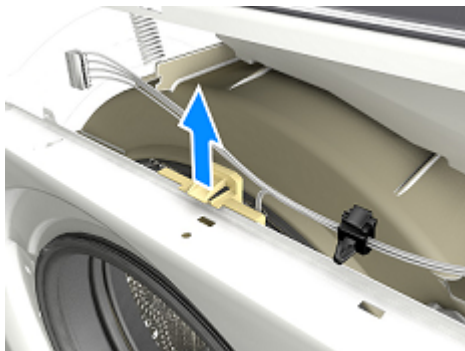

- 2.



⚠️ FORSIKTIG

Fare for at deler kan falle ned på grunn av løsnede skruer!
Personskade på grunn av fallende deler.
▶ Sikre komponenten så den ikke kan falle ned.



OBS!

Fare for at deler kan falle ned på grunn av løsnede skruer!
Skade på andre deler på apparatet eller i kundens hjem, f.eks. gulv.
▶ Sikre komponenten så den ikke kan falle ned.

Løsne skruene i vist rekkefølge.



3. Demonter frontpanelet.

4.11.2 Montering av frontpanel

- ▶ Monteres i motsatt rekkefølge.

Wskazówki naprawy - Pralka

Informacje dotyczące dokumentu 339

| | | |
|-------|---------------------------------------|-----|
| 1.1 | Ważne informacje | 339 |
| 1.1.1 | Cel dokumentu | 339 |
| 1.2 | Objaśnienie symboli ostrzegawczych | 339 |
| 1.2.1 | Oznaczenie poziomów niebezpieczeństwa | 339 |
| 1.2.2 | Symbole ostrzegawcze | 339 |
| 1.2.3 | Budowa ostrzeżeń | 340 |
| 1.2.4 | Ogólne symbole | 340 |

Bezpieczeństwo 341

| | | |
|-------|--|-----|
| 2.1 | Ogólne informacje dotyczące bezpieczeństwa | 341 |
| 2.1.1 | Wszystkie sprzęty gospodarstwa domowego | 341 |

Narzędzia i pomoce techniczne 342

Naprawy 343

| | | |
|-------|---------------------------------------|-----|
| 4.1 | Wymiana panelu przedniego | 343 |
| 4.1.1 | Demontaż panelu przedniego | 343 |
| 4.1.2 | Montaż panelu przedniego | 344 |
| 4.2 | Wymiana dozownika detergentu | 345 |
| 4.2.1 | Demontaż dozownika detergentu | 345 |
| 4.2.2 | Montaż dozownika detergentu | 345 |
| 4.3 | Wymiana uchwyty dozownika detergentu | 346 |
| 4.3.1 | Demontaż uchwyty dozownika detergentu | 346 |
| 4.3.2 | Montaż uchwyty dozownika detergentu | 346 |
| 4.4 | Wymiana drzwi | 347 |
| 4.4.1 | Demontaż drzwi | 347 |
| 4.4.2 | Montaż drzwi | 347 |
| 4.5 | Wymiana komponentów drzwiczek | 348 |
| 4.5.1 | Demontaż komponentów drzwiczek | 348 |
| 4.5.2 | Montaż komponentów drzwiczek | 348 |
| 4.6 | Wymiana zawiasu drzwi | 349 |
| 4.6.1 | Demontaż zawiasu drzwi | 349 |
| 4.6.2 | Montaż zawiasu drzwi | 349 |
| 4.7 | Wymiana uszczelki drzwi | 350 |
| 4.7.1 | Demontaż uszczelki drzwi | 350 |
| 4.7.2 | Montaż uszczelki drzwi | 351 |

| | | |
|--------|----------------------------|-----|
| 4.8 | Wymiana blokady drzwi | 352 |
| 4.8.1 | Demontaż blokady drzwi | 352 |
| 4.8.2 | Montaż blokady drzwi | 353 |
| 4.9 | Wymiana oświetlenia bębna | 354 |
| 4.9.1 | Demontaż oświetlenia bębna | 354 |
| 4.9.2 | Montaż oświetlenia bębna | 354 |
| 4.10 | Wymiana dolnej pokrywy | 355 |
| 4.10.1 | Demontaż dolnej pokrywy | 355 |
| 4.10.2 | Montaż pokrywy | 356 |
| 4.11 | Wymiana ściany przedniej | 357 |
| 4.11.1 | Demontaż ściany przedniej | 357 |
| 4.11.2 | Montaż ściany przedniej | 358 |

i Informacje dotyczące dokumentu

1.1 Ważne informacje

1.1.1 Cel dokumentu

Niniejsze wskazówki naprawcze mają na celu zapewnienie użytkownikowi pomocy w samodzielnej naprawie posiadanych urządzeń w sposób zgodny z obowiązującymi przepisami w sprawie ekoprojektu (stan na 03/2021).

Zawierają one informacje na temat wymiany określonych części zamiennych oraz ostrzeżenia i informacje o zagrożeniach.

W razie pytań należy się skontaktować z naszym działem serwisowym. Odpowiedzialność za szkody ponosimy tylko pod warunkiem prawidłowego stosowania się do wskazówek naprawczych.

1.2 Objasnienie symboli ostrzegawczych

1.2.1 Oznaczenie poziomów niebezpieczeństwa

Poziom ryzyka jest określany przy pomocy symbolu oraz wyrazu. Wyraz określa poziom ryzyka.



| Symbol | Znaczenie |
|--|--|
|  NIEBEZPIECZEŃSTWO | Bezpośrednio zagrażające niebezpieczeństwo, które przy niezachowaniu odpowiednich środków ostrożności może doprowadzić do śmierci lub poważnych obrażeń. |
|  OSTRZEŻENIE | Prawdopodobieństwo wystąpienia niebezpieczeństwa, które przy niezachowaniu odpowiednich środków ostrożności może doprowadzić do śmierci lub poważnych obrażeń. |
|  WAŻNE | Prawdopodobieństwo wystąpienia niebezpieczeństwa, które przy niezachowaniu odpowiednich środków ostrożności może doprowadzić do powstania lekkich obrażeń. |
| UWAGA! | Ostrzeżenie dot. możliwości powstania szkody materialnej. |

Tabela 1: Oznaczenie poziomów niebezpieczeństwa

1.2.2 Symbole ostrzegawcze

Symbole ostrzegawcze reprezentują graficznie źródło potencjalnego ryzyka.

W poniższym dokumencie użyto następujących symboli:

| Symbole ostrzegawcze | Znaczenie |
|---|---|
|  | Ogólne ostrzeżenie |
|  | Niebezpieczeństwo od napięcia elektrycznego |
|  | Ryzyko wybuchu |

i Informacje dotyczące dokumentu







| Symbole ostrzegawcze | Znaczenie |
|--|-------------------------------|
|  | Ryzyko obrażeń (rozcięć) |
|  | Ryzyko zmiążdżenia |
|  | Ryzyko oparzenia |
|  | Silne pole magnetyczne |
|  | Promieniowanie nie-jonizujące |

Tabela 2: Symbole ostrzegawcze

1.2.3 Budowa ostrzeżeń

Ostrzeżenia podane w dokumencie mają standardową budowę.

| | |
|---|--|
|  | <p>⚠ NIEBEZPIECZEŃSTWO</p> <p>Typ i źródło ryzyka!! Konsekwencje zignorowania.</p> <ul style="list-style-type: none"> ▶ Środki ochronne. |
|---|--|

Kolejne ostrzeżenie wskazuje, jako źródło możliwość porażenia prądem. Wskazano czynności, które mają za zadanie ograniczenie ryzyka.

| | |
|--|---|
|  | <p>⚠ NIEBEZPIECZEŃSTWO</p> <p>Ryzyko porażenia prądem, ze względu na elementy będące pod napięciem! Zagrożenie życia poprzez porażenie prądem</p> <ul style="list-style-type: none"> ▶ Odłączyć urządzenie od zasilania sieciowego na 60 sekund przed rozpoczęciem naprawy. |
|--|---|

1.2.4 Ogólne symbole

Poniższe symbole są używane w dokumentacji:







| Symbol | Znaczenie |
|---|---|
|  | Identyfikacja specjalnej wskazówki (tekst lub grafika) |
|  | Identyfikacja prostej wskazówki (tylko tekst) |
|  | Identyfikacja linku do pliku wideo |
|  | Identyfikacja narzędzi |
|  | Identyfikacja wstępnych warunków |
|  | Identyfikacja warunku (jeżeli) |
|  | Identyfikacja rezultatu |
| [Start] | Identyfikacja przycisku |
| [00123456] | Identyfikacja numeru materiału |
| Status | Identyfikacja wyświetlanego tekstu / komunikatu (na wyświetlaczu) |

Tabela 3: Ogólne symbole

2.1 Ogólne informacje dotyczące bezpieczeństwa

2.1.1 Wszystkie sprzęty gospodarstwa domowego

Ryzyko porażenia prądem elektrycznym wskutek kontaktu z elementami znajdującymi się pod napięciem!

- Błędna naprawa części elektrycznych może spowodować porażenie prądem elektrycznym!
- Co najmniej 60 sekund przed przystąpieniem do pracy odłączyć urządzenie od sieci elektrycznej.
- Po naprawie należy przeprowadzić test bezpieczeństwa zgodny z przepisami normy VDE 0701 (Niemcy) lub odpowiednimi przepisami obowiązującymi w kraju użytkowania.

Ryzyko zranienia o ostre krawędzie!

- Używać rękawic ochronnych.

Ryzyko zmiżdżenia podczas naprawy, obsługi lub diagnozy, ze względu na ciężkie i ruchome elementy

- Stosować obuwie ochronne.
- Zabezpieczyć ciężkie elementy przed upadkiem.
- Nie dotykać ruchomych elementów podczas pracy urządzenia.







Zagrożenie dla bezpieczeństwa użytkownika i działania urządzenia!





- Używać tylko oryginalnych części zamiennych.

Ryzyko uszkodzenia komponentów wrażliwych na wyładowania elektrostatyczne (ESD)!

- Nie dotykać modułów, włącznie ze złączami i ścieżkami przewodzącymi.

Narzędzia i pomoce techniczne

| Przeznaczenie | Detale | Zdjęcia |
|--|--|--|
| Narzędzie pomocnicze [15000155] | Narzędzie do poluzowania plastikowych części |  |
| Śrubokręt typu Torx T20 z gniazdem [00340764] | 100 mm, do wkrętów z trzpieniem zabezpieczającym |  |
| Klucz dynamometryczny [15000441] | Klucz dynamometryczny 20 - 100 Nm | |
| Śrubokręt z końcówką płaską [00340854] | Końcówka 3,5 mm x 0,6 mm x 100 mm, izolacja ochronna 1000 V AC |  |
| Śrubokręt z końcówką płaską [00340855] | Końcówka 5,5 mm x 1,0 mm x 125 mm, izolacja ochronna 1000 V AC |  |
| Szczypce wydłużone, wygięte [00341269] | Długość 200 mm |  |
| Szczypce z nożami bocznymi [00342182] | Długość: 200 mm |  |

| Przeznaczenie | Detale | Zdjęcia |
|------------------------------------|---------------------------|---|
| Klucz płasko-oczkowy [00340811] | Rozmiar klucza 10°mm, M6 |  |
| Combination wrench [00340814] | Rozmiar klucza 13°mm, M8 |  |
| Klucz płasko-oczkowy [00340817] | Rozmiar klucza 17 mm, M10 |  |
| Klucz płasko-oczkowy [15000459] | Rozmiar klucza 16°mm, M10 |  |

4.1 Wymiana panelu przedniego



WAŻNE

Ostre krawędzie obudowy!

Rany cięte

- ▶ Zawsze używaj rękawic ochronnych.



OSTRZEŻENIE

Możliwość wyślizgnięcia się przechylonego urządzenia!

Złamania kości / zmiążdżenia

- ▶ Zabezpieczyć urządzenia przed wyślizgnięciem.



WAŻNE

Niebezpieczeństwo spadnięcia części po wykręceniu śrub!

Zranienie przez spadające części.

- ▶ Zabezpieczyć część przed spadnięciem.



UWAGA!

Niebezpieczeństwo spadnięcia części po wykręceniu śrub!

Uszkodzenie innych części urządzenia albo pomieszczenia mieszkalnego, np. podłogi.

- ▶ Zabezpieczyć część przed spadnięciem.

Warunek:

- ✔ Urządzenie odłączone od źródła zasilania.
- ✔ Urządzenie jest odłączone od źródła wody.
- ✔ Urządzenie jest swobodnie dostępne.
- ✔ [Dozownik detergentu został wyjęty. → 345](#)

4.1.1 Demontaż panelu przedniego

1. Zwolnić zatrzask (1).
2. Zdjąć pokrywę (2).

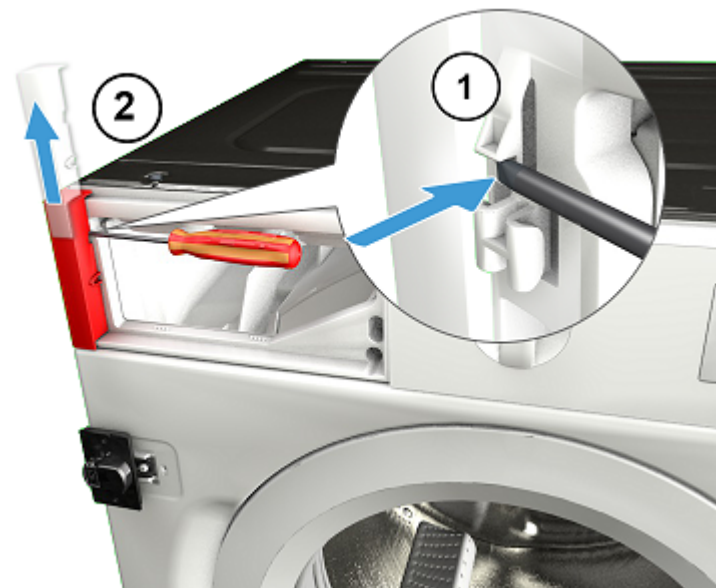

2. Odkręcić śruby.

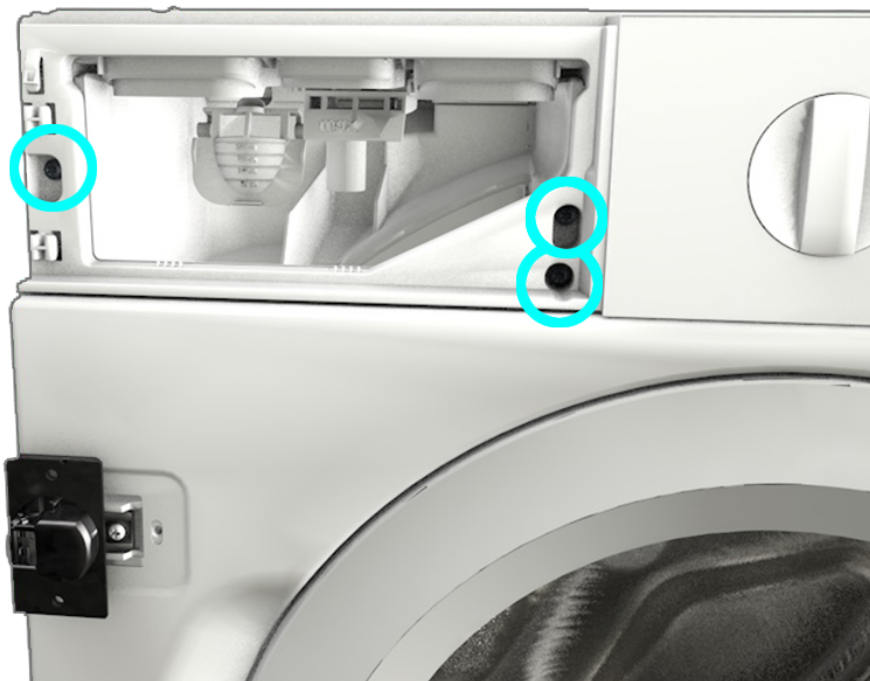

3. 1. Zwolnić zatrzaski (1, 2).
2. Pociągnąć panel przedni do przodu (3).

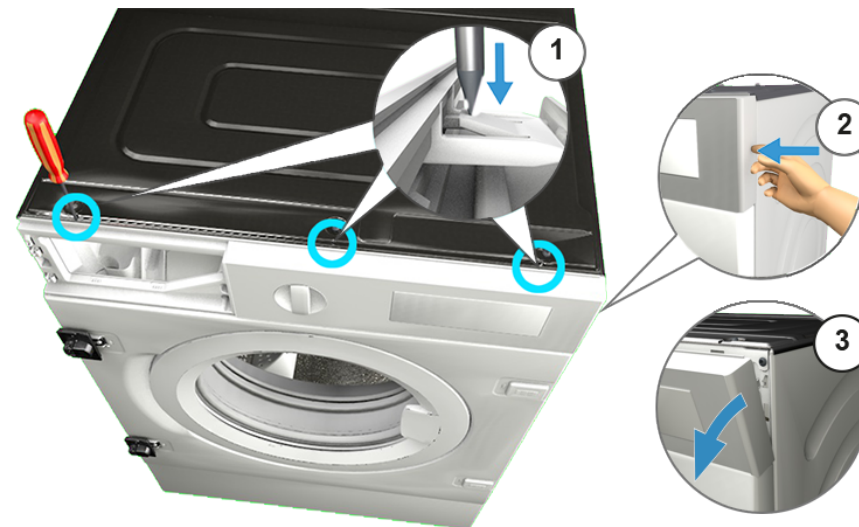

4. Zdjąć panel przedni.

4.1.2 Montaż panelu przedniego

► Montaż w odwrotnej kolejności.

4.2 Wymiana dozownika detergentu

Warunek:

- ✔ Urządzenie odłączone od źródła zasilania.
- ✔ Urządzenie jest odłączone od źródła wody.

4.2.1 Demontaż dozownika detergentu

1. Wysunąć dozownik detergentu.
2. 1. Nacisnąć wsuwaną część do dołu (1).
2. Wyjąć dozownik detergentu (2).

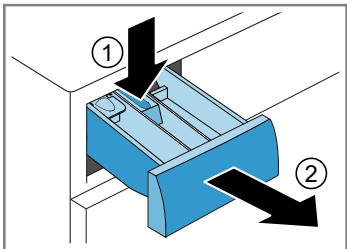

4.2.2 Montaż dozownika detergentu

- ▶ Montaż w odwrotnej kolejności.

4.3 Wymiana uchwyty dozownika detergentu

Warunek:

- ✔ Urządzenie odłączone od źródła zasilania.
- ✔ Urządzenie jest odłączone od źródła wody.
- ✔ [Dozownik detergentu został wyjęty. → 345](#)

4.3.1 Demontaż uchwyty dozownika detergentu

1. Zwolnić zatrzaski.

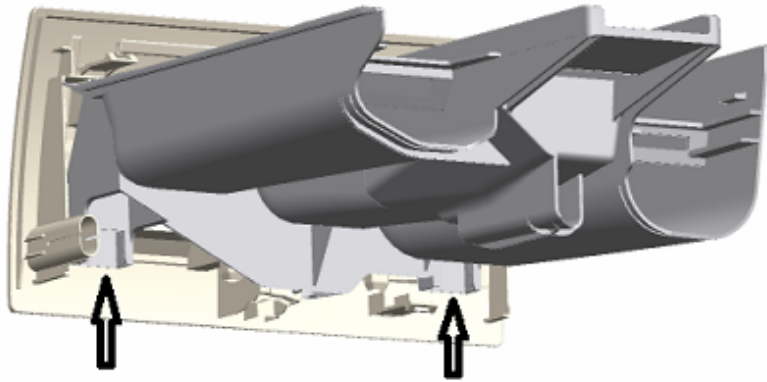

2. Wyjąć uchwyt dozownika detergentu.

4.3.2 Montaż uchwyty dozownika detergentu

- ▶ Montaż w odwrotnej kolejności.

4.4 Wymiana drzwi



WAŻNE

Odsłonięty zawias!

Zmiażdżenie / uwięzienie palca

- ▶ Nie wkładać rąk pod zawiasy.
- ▶ Zawsze używaj rękawic ochronnych.

Warunek:

- ✔ Urządzenie odłączone od źródła zasilania.
- ✔ Urządzenie jest odłączone od źródła wody.
- ✔ Drzwiczki są otwarte.
- ✔ Panel meblowy został zdemontowany.

4.4.1 Demontaż drzwi

1.



UWAGA!

Niebezpieczeństwo spadnięcia części po wykręceniu śrub!

Uszkodzenie innych części urządzenia albo pomieszczenia mieszkalnego, np. podłogi.

- ▶ Zabezpieczyć część przed spadnięciem.



WAŻNE

Niebezpieczeństwo spadnięcia części po wykręceniu śrub!

Zranienie przez spadające części.

- ▶ Zabezpieczyć część przed spadnięciem.

Wykręcić śruby (1).

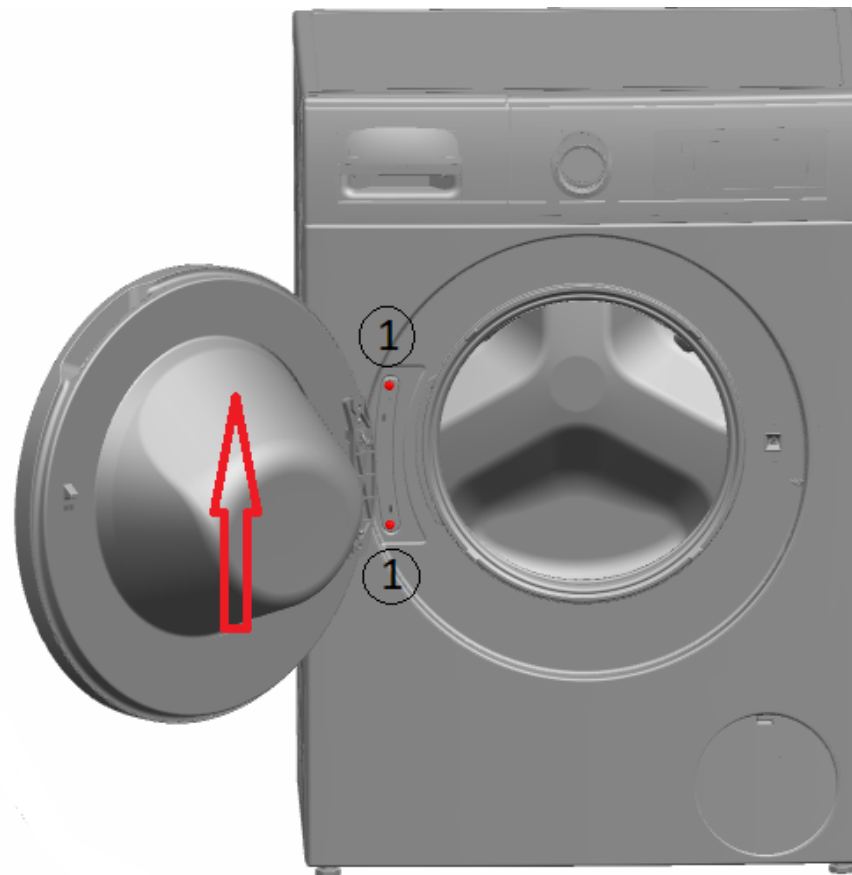

2. Wyjąć drzwiczki do góry.

4.4.2 Montaż drzwi

- ▶ Montaż w odwrotnej kolejności.

4.5 Wymiana komponentów drzwiczek



WAŻNE

Odsłonięty zawias!

Zmiażdżenie / uwięzienie palca

- ▶ Nie wkładać rąk pod zawiasy.
- ▶ Zawsze używaj rękawic ochronnych.

Warunek:

- ✔ Urządzenie odłączone od źródła zasilania.
- ✔ Urządzenie jest odłączone od źródła wody.
- ✔ Panel meblowy został zdemontowany.
- ✔ [Drzwi zostały zdemontowane. → 347](#)

4.5.1 Demontaż komponentów drzwiczek

- ▶ Zdemontować drzwiczki od zewnątrz do wewnątrz.

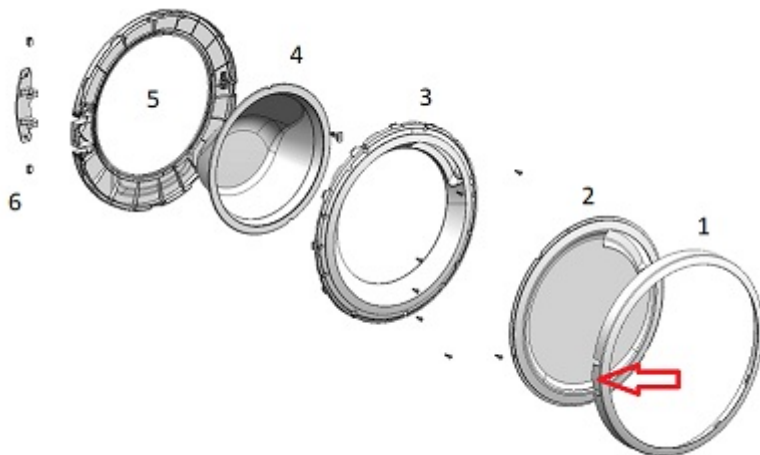

4.5.2 Montaż komponentów drzwiczek

- ▶ Montaż w odwrotnej kolejności.

4.6 Wymiana zawiasu drzwi



WAŻNE

Odsłonięty zawias!

Zmiażdżenie / uwięzienie palca

- ▶ Nie wkładać rąk pod zawiasy.
- ▶ Zawsze używaj rękawic ochronnych.

Warunek:

- ✔ Urządzenie odłączone od źródła zasilania.
- ✔ Urządzenie jest odłączone od źródła wody.

4.6.1 Demontaż zawiasu drzwi

1. Odkręcić dwie śruby.
2. Wyjąć drzwiczki.
3. Zdemontować drzwiczki od zewnątrz do wewnątrz.

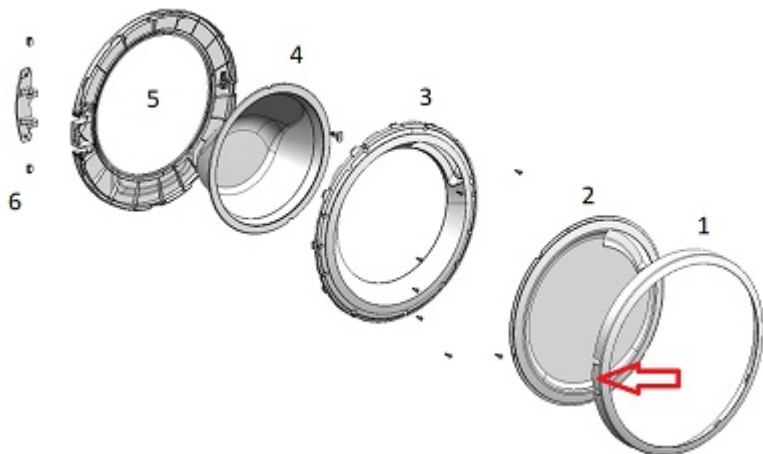



4. Wyjąć zawias drzwiczek.

4.6.2 Montaż zawiasu drzwi

- ▶ Montaż w odwrotnej kolejności.

4.7 Wymiana uszczelki drzwi

| | |
|--|--|
|  | WAŻNE Ostre krawędzie obudowy! Rany cięte ▶ Zawsze używaj rękawic ochronnych. |
|--|--|

| | |
|--|--|
|  | WAŻNE Niebezpieczeństwo spadnięcia części po wykręceniu śrub! Zranienie przez spadające części. ▶ Zabezpieczyć część przed spadnięciem. |
|--|--|

| | |
|--|--|
|  | UWAGA! Niebezpieczeństwo spadnięcia części po wykręceniu śrub! Uszkodzenie innych części urządzenia albo pomieszczenia mieszkalnego, np. podłogi. ▶ Zabezpieczyć część przed spadnięciem. |
|--|--|

Warunek:

- ✔ Urządzenie odłączone od źródła zasilania.
- ✔ Urządzenie jest odłączone od źródła wody.
- ✔ Urządzenie jest swobodnie dostępne.
- ✔ [Dozownik detergentu został wyjęty. → 345](#)
- ✔ Panel przedni został zdemontowany.
- ✔ [Drzwi zostały zdemontowane. → 347](#)
- ✔ [Dolna pokrywa została zdemontowana. → 355](#)

4.7.1 Demontaż uszczelki drzwi

1. Poluzować zacisk mocujący oświetlenie bębna.

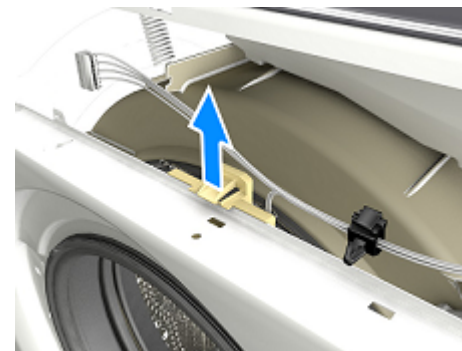

2.

| | |
|---|---|
|  | UWAGA! Niebezpieczeństwo uszkodzenia powierzchni! Użycie nieodpowiednich narzędzi może porysować powierzchnię urządzenia. ▶ Do wymiany pierścienia naprężającego używać tylko plastikowych narzędzi. |
|---|---|

Wyjąć pierścień naprężający z uszczelki, używając plastikowego narzędzia.

3. Wyjąć uszczelkę drzwiczek ze ściany przedniej.
4. Odłączyć złącze kabla od zamka drzwiczek.

5. Poluzować śruby w pokazanej kolejności.



6. Zdjąć ścianę przednią.

7. Rozłączyć wszystkie złącza węży.

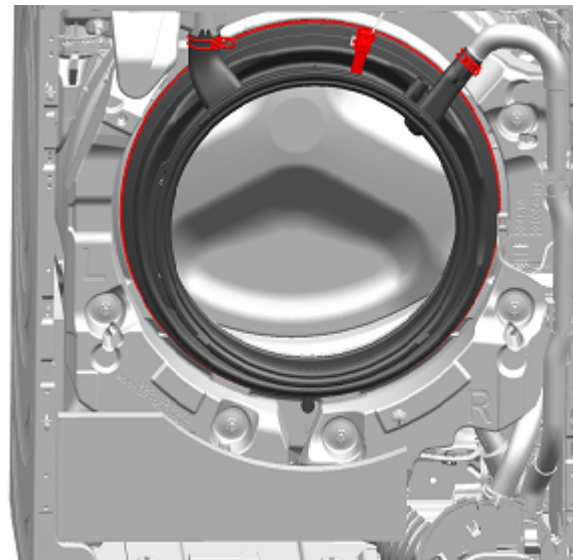

8. Wyjąć uszczelkę drzwiczek.

4.7.2 Montaż uszczelki drzwi

► Montaż w odwrotnej kolejności.

4.8 Wymiana blokady drzwi

Jako producent mamy zgodnie z rozporządzeniem (UE) 2019/2023 obowiązek udostępnienia klientowi zamka drzwiczek jako części zamiennej wraz z instrukcją naprawy. Informujemy jednak, że przed ponownym rozpoczęciem użytkowania urządzenia po wymianie drzwiczek konieczne jest przeprowadzenie testu bezpieczeństwa elektrotechnicznego przez wykwalifikowanego elektryka. Osoba ta musi posiadać kwalifikacje i uprawnienia wymagane zgodnie z ustawodawstwem, przepisami i normami kraju użytkowania.

| | |
|--|---|
|  | ⚠ NIEBEZPIECZEŃSTWO |
| | <p>Ryzyko porażenia prądem elektrycznym wskutek kontaktu z elementami znajdującymi się pod napięciem! Niebezpieczeństwo utraty życia wskutek porażenia prądem elektrycznym w przypadku nieprawidłowej naprawy</p> <ul style="list-style-type: none"> ▶ Części elektryczne powinny być naprawiane przez wykwalifikowanych elektryków. ▶ Po naprawie należy przeprowadzić test bezpieczeństwa zgodny z przepisami normy VDE 0701 (Niemcy) lub odpowiednimi przepisami obowiązującymi w kraju użytkowania. |

| | |
|--|--|
|  | ⚠ WAŻNE |
| | <p>Ostre krawędzie obudowy! Rany cięte</p> <ul style="list-style-type: none"> ▶ Zawsze używaj rękawic ochronnych. |

| | |
|---|--|
|  | ⚠ OSTRZEŻENIE |
| | <p>Możliwość wyslizgnięcia się przechylonego urządzenia! Złamania kości / zmiżdżenia</p> <ul style="list-style-type: none"> ▶ Zabezpieczyć urządzenia przed wyslizgnięciem. |

| | |
|--|--|
|  | ⚠ WAŻNE |
| | <p>Niebezpieczeństwo spadnięcia części po wykręceniu śrub! Zranienie przez spadające części.</p> <ul style="list-style-type: none"> ▶ Zabezpieczyć część przed spadnięciem. |

| | |
|---|---|
|  | UWAGA! |
| | <p>Niebezpieczeństwo spadnięcia części po wykręceniu śrub! Uszkodzenie innych części urządzenia albo pomieszczenia mieszkalnego, np. podłogi.</p> <ul style="list-style-type: none"> ▶ Zabezpieczyć część przed spadnięciem. |

Warunek:

- ✓ Urządzenie odłączone od źródła zasilania.
- ✓ Urządzenie jest odłączone od źródła wody.
- ✓ Urządzenie jest swobodnie dostępne.
- ✓ Panel meblowy został zdemontowany.
- ✓ Panel przedni został zdemontowany.
- ✓ [Drzwi zostały zdemontowane. → 347](#)
- ✓ Pierścień naprężający został zdemontowany.
- ✓ Ściana przednia została zdemontowana.
- ✓ Została wyjęta uszczelka drzwiczek.

4.8.1 Demontaż blokady drzwi

1. Odłączyć wtyczkę zamka drzwiczek.
2. Zwolnić blokadę drzwi.



3. Wyjąć blokadę drzwi.

4.8.2 Montaż blokady drzwi

Blokada drzwiczek musi się znajdować w poprawnej pozycji w celu zapewnienia możliwości awaryjnego otwarcia drzwiczek urządzenia.

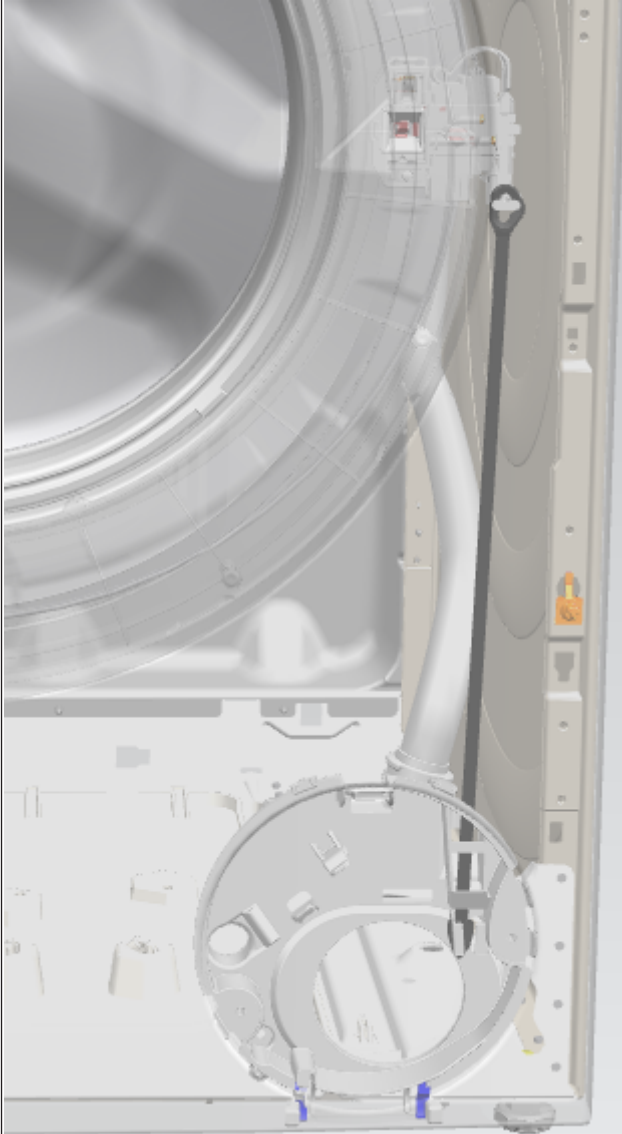

- ▶ Montaż w odwrotnej kolejności.

4.9 Wymiana oświetlenia bębna



WAŻNE

Ostre krawędzie obudowy!

Rany cięte

- ▶ Zawsze używaj rękawic ochronnych.



OSTRZEŻENIE

Możliwość wyślizgnięcia się przechylonego urządzenia!

Złamania kości / zmiżdżenia

- ▶ Zabezpieczyć urządzenia przed wyślizgnięciem.



WAŻNE

Niebezpieczeństwo spadnięcia części po wykręceniu śrub!

Zranienie przez spadające części.

- ▶ Zabezpieczyć część przed spadnięciem.



UWAGA!

Niebezpieczeństwo spadnięcia części po wykręceniu śrub!

Uszkodzenie innych części urządzenia albo pomieszczenia mieszkalnego, np. podłogi.

- ▶ Zabezpieczyć część przed spadnięciem.

Warunek:

- ✔ Urządzenie odłączone od źródła zasilania.
- ✔ Urządzenie jest odłączone od źródła wody.
- ✔ Urządzenie jest swobodnie dostępne.
- ✔ [Dozownik detergentu został wyjęty. → 345](#)
- ✔ Panel przedni został zdemontowany.

4.9.1 Demontaż oświetlenia bębna

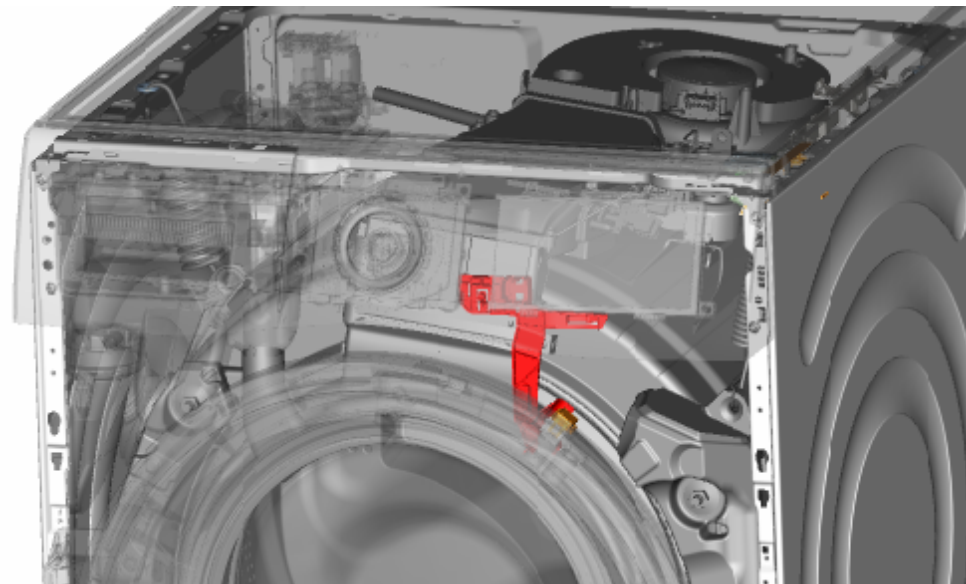

1. Wyciągnąć uchwyt oświetlenia bębna z urządzenia.
2. Rozłączyć złącza elektryczne.
3. Wyjąć oświetlenie bębna z uchwytu oświetlenia bębna.

4.9.2 Montaż oświetlenia bębna

- ▶ Montaż w odwrotnej kolejności.

4.10 Wymiana dolnej pokrywy



Rys. 1: Dolna pokrywa zbiorcza

Warunek:

- ✔ Urządzenie odłączone od źródła zasilania.
- ✔ Urządzenie jest odłączone od źródła wody.
- ✔ Panel meblowy został zdemontowany.

4.10.1 Demontaż dolnej pokrywy

Warunek:

- ✔ Urządzenie odłączone od źródła zasilania.
- ✔ Urządzenie jest odłączone od źródła wody.

1. Wyjąć dolną pokrywę.

2. Odłączyć wąż od uchwyty.

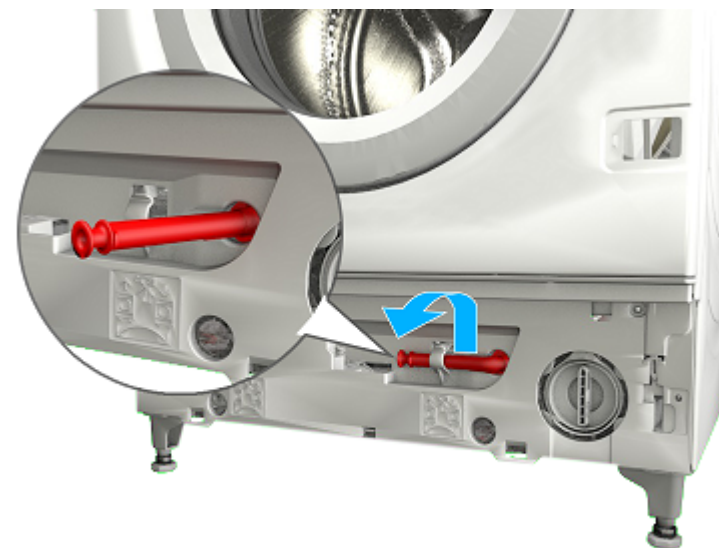

Naprawy

3. 1. Odkręcić śrubę (1).
2. Wcisnąć element zwalniający i wyjąć do dołu (2).

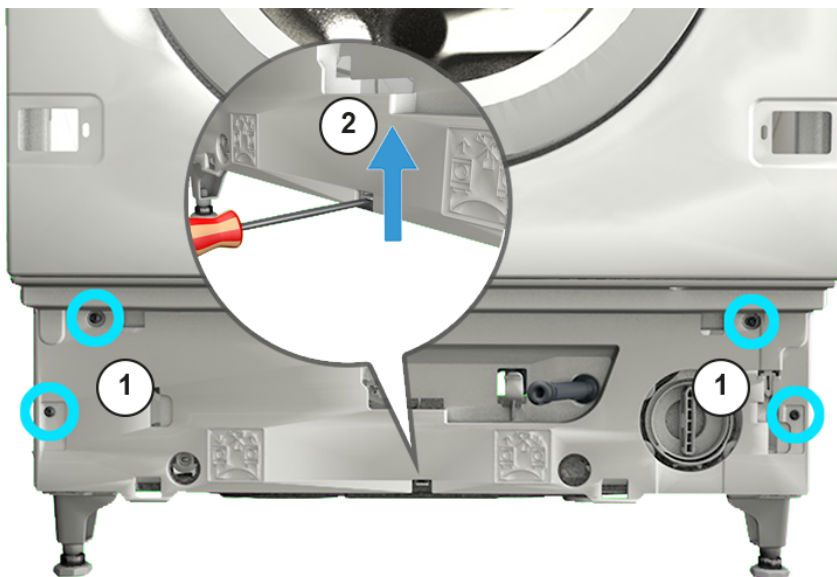

4. Pociągnąć dolną pokrywę zbiorczą i wyjąć do przodu.

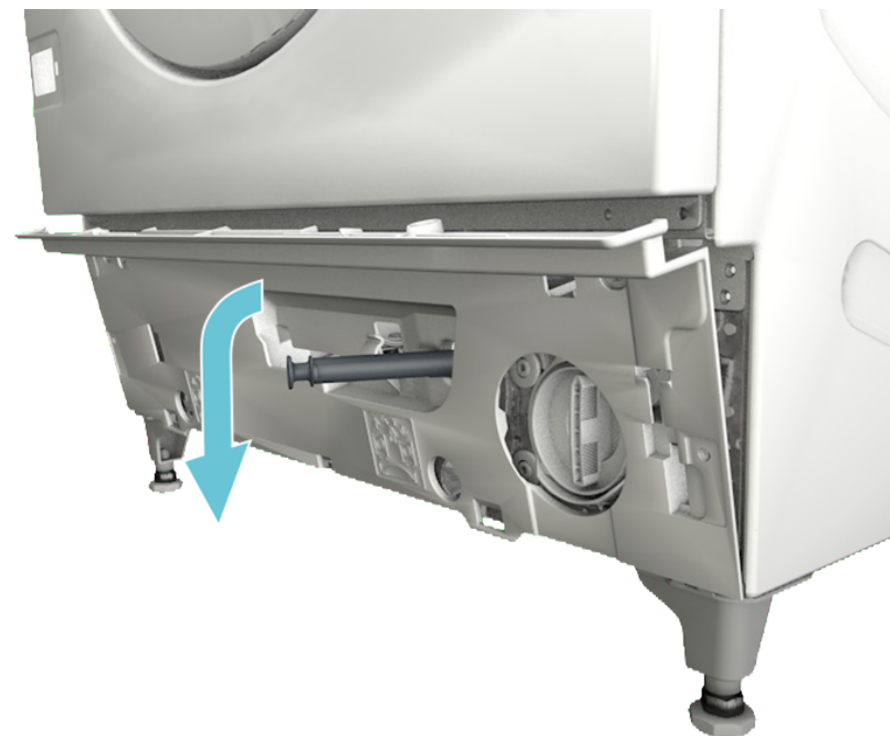

5. Wyciągnąć wąż z pokrywy.

4.10.2 Montaż pokrywy

- Montaż w odwrotnej kolejności.

4.11 Wymiana ściany przedniej



WAŻNE

Ostre krawędzie obudowy!

Rany cięte

- ▶ Zawsze używaj rękawic ochronnych.

Warunek:

- ✔ Urządzenie odłączone od źródła zasilania.
- ✔ Urządzenie jest odłączone od źródła wody.
- ✔ Urządzenie jest swobodnie dostępne.
- ✔ [Dozownik detergentu został wyjęty. → 345](#)
- ✔ Panel meblowy został zdemontowany.
- ✔ [Drzwi zostały zdemontowane. → 347](#)
- ✔ Została wyjęta uszczelka drzwiczek.

4.11.1 Demontaż ściany przedniej

1. Poluzować zacisk mocujący oświetlenie bębna.

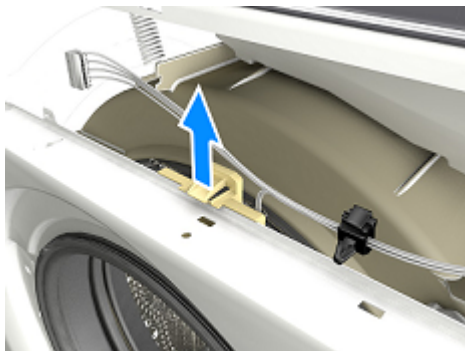

2.



WAŻNE

Niebezpieczeństwo spadnięcia części po wykręceniu śrub!

Zranienie przez spadające części.

- ▶ Zabezpieczyć część przed spadnięciem.



UWAGA!

Niebezpieczeństwo spadnięcia części po wykręceniu śrub!

Uszkodzenie innych części urządzenia albo pomieszczenia mieszkalnego, np. podłogi.

- ▶ Zabezpieczyć część przed spadnięciem.

Poluzować śruby w pokazanej kolejności.



3. Zdjąć ścianę przednią.

4.11.2 Montaż ściany przedniej

- ▶ Montaż w odwrotnej kolejności.

Dicas de resolução - Máquina de lavar roupa

Sobre este documento..... 360

| | | |
|-------|------------------------------|-----|
| 1.1 | Informação importante..... | 360 |
| 1.1.1 | Finalidade..... | 360 |
| 1.2 | Explicação dos símbolos..... | 360 |
| 1.2.1 | Níveis de perigo..... | 360 |
| 1.2.2 | Símbolos de perigo..... | 360 |
| 1.2.3 | Estrutura dos avisos..... | 361 |
| 1.2.4 | Símbolos gerais..... | 361 |

Segurança..... 362

| | | |
|-------|-------------------------------------|-----|
| 2.1 | Instruções gerais de segurança..... | 362 |
| 2.1.1 | Todos os eletrodomésticos..... | 362 |

Ferramentas e auxiliares..... 363

Reparação..... 364

| | | |
|-------|--|-----|
| 4.1 | Substituir o painel dos comandos..... | 364 |
| 4.1.1 | Remover o painel dos comandos..... | 364 |
| 4.1.2 | Instalar o painel dos comandos..... | 365 |
| 4.2 | Substituir a gaveta para detergente..... | 366 |
| 4.2.1 | Remover a gaveta para detergente..... | 366 |
| 4.2.2 | Instalar a gaveta para detergente..... | 366 |
| 4.3 | Substituir a pega da gaveta para detergente..... | 367 |
| 4.3.1 | Remover a pega da gaveta para detergente..... | 367 |
| 4.3.2 | Instalar a pega da gaveta para detergente..... | 367 |
| 4.4 | Substituir a porta..... | 368 |
| 4.4.1 | Remover a porta..... | 368 |
| 4.4.2 | Instalar a porta..... | 368 |
| 4.5 | Substituir os componentes da porta..... | 369 |
| 4.5.1 | Remover os componentes da porta..... | 369 |
| 4.5.2 | Instalar os componentes da porta..... | 369 |
| 4.6 | Substituir a dobradiça da porta..... | 370 |
| 4.6.1 | Remover a dobradiça da porta..... | 370 |
| 4.6.2 | Instalar a dobradiça da porta..... | 370 |
| 4.7 | Substituir a vedação da porta..... | 371 |
| 4.7.1 | Remover a vedação da porta..... | 371 |
| 4.7.2 | Instalar a vedação da porta..... | 372 |

| | | |
|--------|--|-----|
| 4.8 | Substituir o dispositivo de bloqueio da porta..... | 373 |
| 4.8.1 | Remover o dispositivo de bloqueio da porta..... | 373 |
| 4.8.2 | Instalar o dispositivo de bloqueio da porta..... | 374 |
| 4.9 | Substituir a luz do tambor..... | 375 |
| 4.9.1 | Remover a luz do tambor..... | 375 |
| 4.9.2 | Instalar a luz do tambor..... | 375 |
| 4.10 | Substituir a tampa inferior..... | 376 |
| 4.10.1 | Remover a tampa inferior..... | 376 |
| 4.10.2 | Instalar a tampa..... | 377 |
| 4.11 | Substituir o painel frontal..... | 378 |
| 4.11.1 | Remover o painel frontal..... | 378 |
| 4.11.2 | Instalar o painel frontal..... | 379 |

i Sobre este documento

1.1 Informação importante

1.1.1 Finalidade

Estas dicas de reparação auxiliam o consumidor na reparação de aparelhos por ele próprio de acordo com o regulamento de "Eco-design" aplicável (a partir de 03/2021).

Estas contêm informações sobre como substituir peças sobressalentes definidas, incluindo avisos e riscos.

Em caso de dúvidas, entre em contacto com o nosso serviço de apoio ao cliente. Apenas nos responsabilizaremos por danos se as dicas de reparação tiverem sido devidamente seguidas.

1.2 Explicação dos símbolos

1.2.1 Níveis de perigo

Os níveis de aviso são compostos por um símbolo e uma palavra sinal. A palavra-sinal indica a gravidade do perigo.







| Nível de aviso | Significado |
|---|---|
|  | A não observância da mensagem de aviso resulta em morte ou ferimentos graves. |
|  | A não observância da mensagem de aviso pode resultar em morte ou ferimentos graves. |
|  | A não observância da mensagem de aviso pode resultar em ferimentos ligeiros. |
|  | A não observância da mensagem de aviso pode resultar em danos materiais. |

Tabela 1: Níveis de perigo

1.2.2 Símbolos de perigo

Os símbolos de perigo são representações simbólicas que dão uma indicação do tipo de perigo.

Neste documento são utilizados os seguintes símbolos de perigo:

| Símbolo de perigo | Significado |
|---|---------------------------|
|  | Mensagem geral de aviso |
|  | Perigo de tensão elétrica |
|  | Risco de explosão |
|  | Perigo de cortes |

i Sobre este documento





| Símbolo de perigo | Significado |
|--|---|
|  | Perigo de esmagamento |
|  | Perigo de superfícies quentes |
|  | Perigo de campo eletromagnético intenso |
|  | Perigo de radiação não-ionizante |

Tabela 2: Símbolos de perigo

1.2.3 Estrutura dos avisos

Os avisos neste documento possuem um aspeto normalizado e uma estrutura normalizada.

| | |
|--|-----------------|
|  | ⚠ PERIGO |
| Tipo e origem do perigo! | |
| Possíveis consequência de ignorar o perigo / aviso. | |
| ▶ Medidas e proibições para prevenir o perigo. | |

O seguinte exemplo mostra um aviso que adverte contra choques elétricos devido a partes sob tensão. A medida para evitar o perigo é mencionada.

| | |
|--|-----------------|
|  | ⚠ PERIGO |
| Risco de choque elétrico devido a partes sob tensão! | |
| Morte por eletrocussão | |
| ▶ Desligue os aparelhos da alimentação elétrica pelo menos 60 segundos antes de iniciar as reparações. | |

1.2.4 Símbolos gerais

Neste documento são utilizados os seguintes símbolos gerais:







| Símbolo ger. | Significado |
|---|---|
|  | Identificação de uma dica especial (texto e/ou ilustração) |
|  | Identificação de uma dica simples (apenas texto) |
|  | Identificação de uma ligação para um tutorial em vídeo |
|  | Identificação das ferramentas necessárias |
|  | Identificação das condições prévias necessárias |
|  | Identificação de uma condição (se ..., então ...) |
|  | Identificação de um resultado |
| Iniciar | Identificação de uma tecla ou botão |
| [00123456] | Identificação de um número de material |
| Estado | Identificação de um texto exibido / janela (no visor do aparelho) |

Tabela 3: Símbolos gerais

2.1 Instruções gerais de segurança

2.1.1 Todos os eletrodomésticos

Risco de choque elétrico devido a partes sob tensão!

- Erros por reparações envolvendo componentes elétricos podem provocar choques elétricos!
- Desligue o aparelho da rede elétrica pelo menos 60 segundos antes de iniciar o trabalho.
- Após a reparação, solicite a realização de um teste de segurança de acordo com VDE 0701 ou os regulamentos específicos do país.

Risco de ferimentos causados por arestas vivas!

- Use luvas de proteção.

Risco de esmagamento durante trabalhos de reparação, manutenção, resolução de problemas e serviço devido a componentes pesados e móveis

- Use calçado de proteção.
- Proteja os componentes pesados contra quedas.
- Não introduzir partes do corpo em componentes móveis.







Risco para a segurança/funcionamento do aparelho!

- Utilize apenas peças sobressalentes originais.

Risco de danos em componentes electrostáticamente sensíveis (ESDs)!





- Não toque nos módulos, incluindo ligações e percursos condutores.

Ferramentas e auxiliares

| Designação | Detalhes | Imagens |
|--|--|--|
| Ferramenta auxiliar [15000155] | Ferramenta para soltar as partes em plástico |  |
| Chave parafusos Torx T20 com orifício [00340764] | 100 mm, para parafusos com pino de segurança |  |
| Chave dinamométrica [15000441] | Chave dinamométrica 20 - 100 Nm | |
| Chave de fenda [00340854] | Lâmina 3,5 mm x 0,6 mm x 100 mm, isolamento protetor 1000 V AC |  |
| Chave de fenda [00340855] | Lâmina 5,5 mm x 1,0 mm x 125 mm, isolamento protetor 1000 V AC |  |
| Alicate de pontas, padrão angular [00341269] | Comprimento 200 mm |  |
| Alicate de corte [00342182] | Comprimento: 200 mm |  |

| Designação | Detalhes | Imagens |
|-------------------------------|-----------------------------|---|
| Chave combinada [00340811] | Tamanho da chave 10ºmm, M6 |  |
| Combination wrench [00340814] | Tamanho da chave 13ºmm, M8 |  |
| Chave combinada [00340817] | Tamanho da chave 17 mm, M10 |  |
| Chave combinada [15000459] | Tamanho da chave 16ºmm, M10 |  |

4.1 Substituir o painel dos comandos

| | |
|--|---|
|  | <p>⚠ CUIDADO</p> <p>Arestas vivas no alojamento! Lesões por corte</p> <ul style="list-style-type: none">▶ Use luvas de proteção. |
|  | <p>⚠ AVISO</p> <p>Deslizamento de aparelhos inclinados! Fraturas ósseas / ferimentos de esmagamento</p> <ul style="list-style-type: none">▶ Proteja os aparelhos contra o deslizamento. |
|  | <p>⚠ CUIDADO</p> <p>Risco de queda de peças devido a parafusos desapertados! Lesões devido à queda de peças.</p> <ul style="list-style-type: none">▶ Proteja o componente contra as quedas. |
|  | <p>ATENÇÃO!</p> <p>Risco de queda de peças devido a parafusos desapertados! Danos em outros componentes do aparelho ou na casa do cliente, p. ex., no pavimento.</p> <ul style="list-style-type: none">▶ Proteja o componente contra as quedas. |

Pré-requisito:

- ✔ O aparelho está desligado da energia.
- ✔ O aparelho está desligado do abastecimento de água.
- ✔ O aparelho está livremente acessível.
- ✔ [A gaveta para detergente foi removida. → 366](#)

4.1.1 Remover o painel dos comandos

1. Solte o elemento de encaixe (1).
2. Remova a tampa (2).

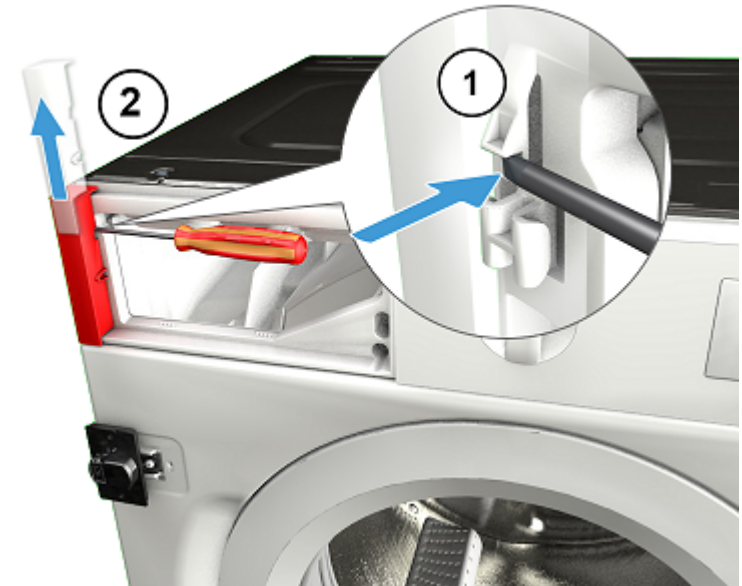

Reparação

2. Remova os parafusos.



3. 1. Solte os elementos de encaixe (1, 2).
2. Puxe o painel dos comandos para a frente (3).

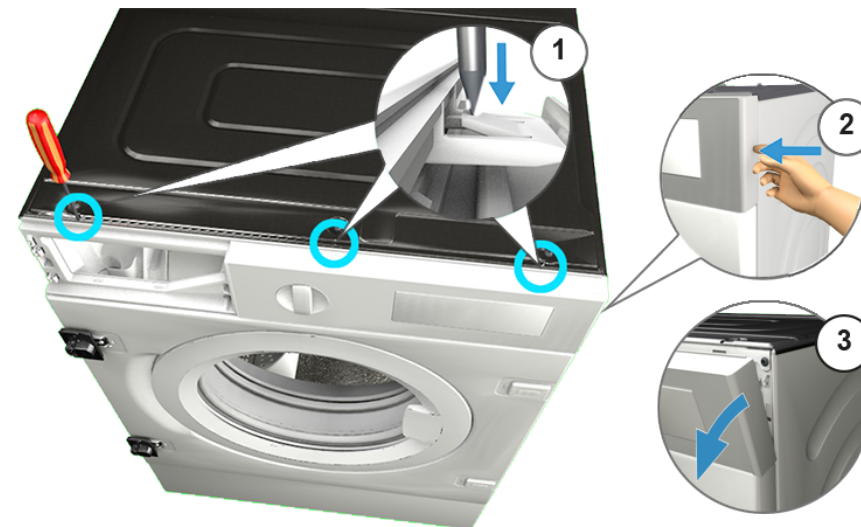

4. Remova o painel dos comandos.

4.1.2 Instalar o painel dos comandos

- Instale pela ordem inversa.

4.2 Substituir a gaveta para detergente

Pré-requisito:

- ✓ O aparelho está desligado da energia.
- ✓ O aparelho está desligado do abastecimento de água.

4.2.1 Remover a gaveta para detergente

1. Puxe a gaveta para detergente para fora.
2. 1. Pressione para baixo ao inserir (1).
2. Remova a gaveta para detergente (2).

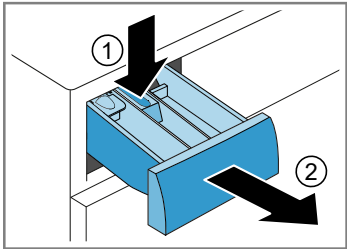

4.2.2 Instalar a gaveta para detergente

- ▶ Instale pela ordem inversa.

4.3 Substituir a pega da gaveta para detergente

Pré-requisito:

- ✓ O aparelho está desligado da energia.
- ✓ O aparelho está desligado do abastecimento de água.
- ✓ [A gaveta para detergente foi removida.→366](#)

4.3.1 Remover a pega da gaveta para detergente

1. Solte os elementos de encaixe.

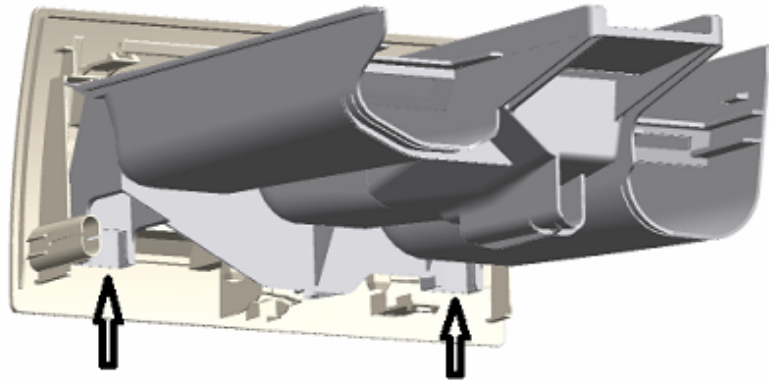

2. Remova a pega da gaveta para detergente.

4.3.2 Instalar a pega da gaveta para detergente

- ▶ Instale pela ordem inversa.

4.4 Substituir a porta



⚠️ CUIDADO

Zona das dobradiças aberta!

Esmagamento / entalamento dos dedos

- ▶ Não coloque as mãos na zona das dobradiças.
- ▶ Use luvas de proteção.

Pré-requisito:

- ✔ O aparelho está desligado da energia.
- ✔ O aparelho está desligado do abastecimento de água.
- ✔ A porta está aberta.
- ✔ A frente do móvel foi removida.

4.4.1 Remover a porta

1.



ATENÇÃO!

Risco de queda de peças devido a parafusos desapertados!

Danos em outros componentes do aparelho ou na casa do cliente, p. ex., no pavimento.

- ▶ Proteja o componente contra as quedas.



⚠️ CUIDADO

Risco de queda de peças devido a parafusos desapertados!

Lesões devido à queda de peças.

- ▶ Proteja o componente contra as quedas.

Remova os parafusos (1).

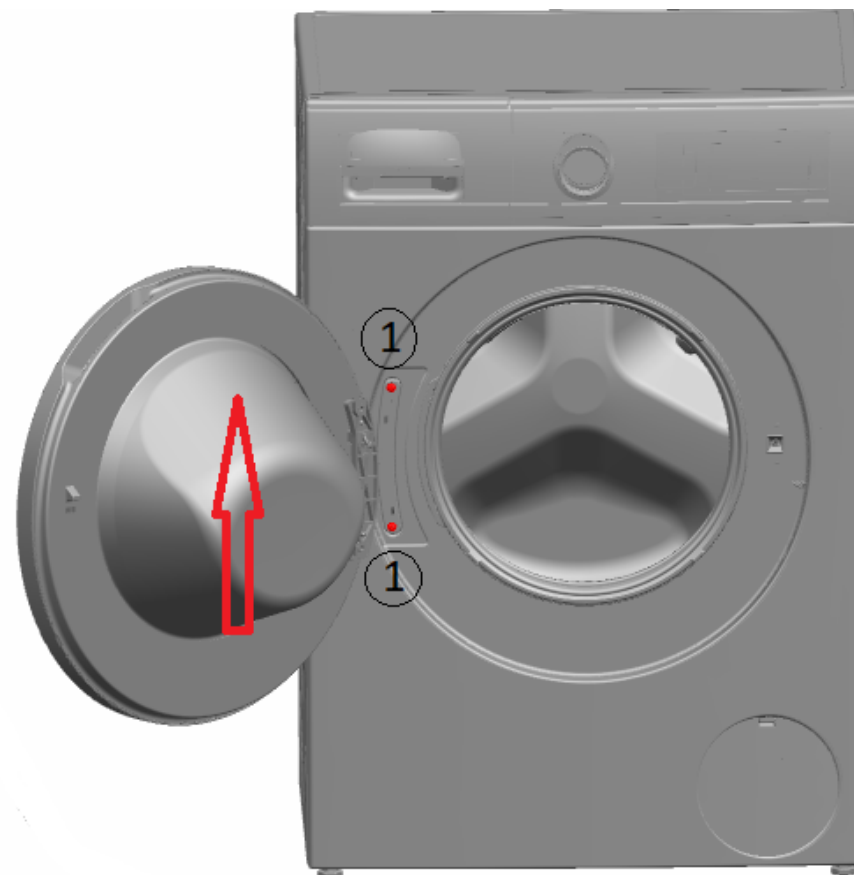

2. Remova a porta para cima.

4.4.2 Instalar a porta

- ▶ Instale pela ordem inversa.

4.5 Substituir os componentes da porta



CUIDADO

Zona das dobradiças aberta!

Esmagamento / entalamento dos dedos

- ▶ Não coloque as mãos na zona das dobradiças.
- ▶ Use luvas de proteção.

Pré-requisito:

- ✔ O aparelho está desligado da energia.
- ✔ O aparelho está desligado do abastecimento de água.
- ✔ A frente do móvel foi removida.
- ✔ [A porta foi removida. → 368](#)

4.5.1 Remover os componentes da porta

- ▶ Desmonte a porta do exterior para o interior.

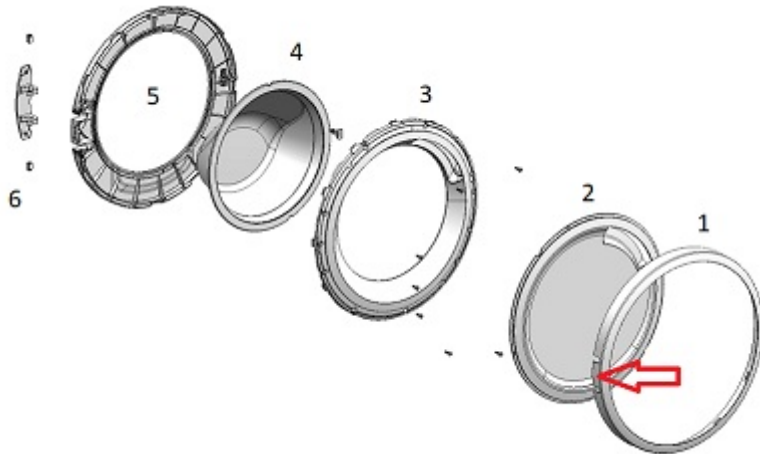

4.5.2 Instalar os componentes da porta

- ▶ Instale pela ordem inversa.

4.6 Substituir a dobradiça da porta



CUIDADO

Zona das dobradiças aberta!

Esmagamento / entalamento dos dedos

- ▶ Não coloque as mãos na zona das dobradiças.
- ▶ Use luvas de proteção.

Pré-requisito:

- ✔ O aparelho está desligado da energia.
- ✔ O aparelho está desligado do abastecimento de água.

4.6.1 Remover a dobradiça da porta

1. Solte dois parafusos.
2. Remova a porta.
3. Desmonte a porta do exterior para o interior.

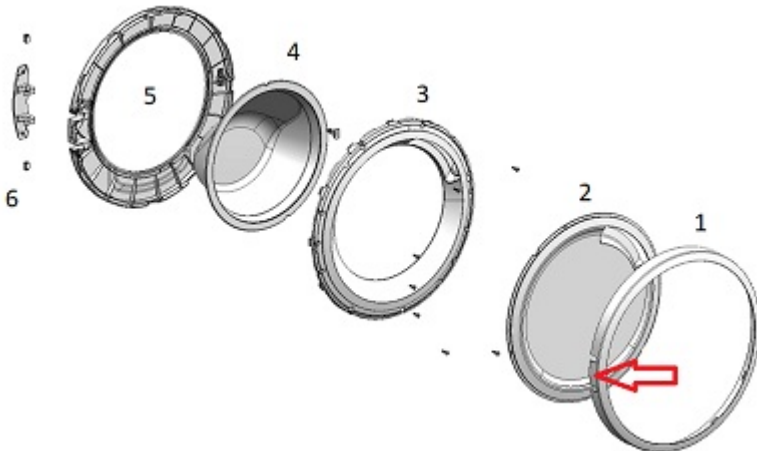

4. Remova a dobradiça da porta.

4.6.2 Instalar a dobradiça da porta

- ▶ Instale pela ordem inversa.

4.7 Substituir a vedação da porta



CUIDADO

Arestas vivas no alojamento!
Lesões por corte
▶ Use luvas de proteção.



CUIDADO

Risco de queda de peças devido a parafusos desapertados!
Lesões devido à queda de peças.
▶ Proteja o componente contra as quedas.



ATENÇÃO!

Risco de queda de peças devido a parafusos desapertados!
Danos em outros componentes do aparelho ou na casa do cliente, p. ex., no pavimento.
▶ Proteja o componente contra as quedas.

Pré-requisito:

- ✔ O aparelho está desligado da energia.
- ✔ O aparelho está desligado do abastecimento de água.
- ✔ O aparelho está livremente acessível.
- ✔ [A gaveta para detergente foi removida.→366](#)
- ✔ O painel da fachada foi removido.
- ✔ [A porta foi removida.→368](#)
- ✔ [A tampa inferior foi removida.→376](#)

4.7.1 Remover a vedação da porta

1. Desaperte o retentor da luz do tambor.



- 2.



ATENÇÃO!

Risco de superfície danificada!
A superfície do aparelho pode ficar riscada devido ao uso das ferramentas erradas.
▶ Utilize exclusivamente ferramentas de plástico para substituir o anel de tensão.

Remova o anel de tensão da junta com uma ferramenta de plástico.

3. Solte a vedação da porta do painel frontal.
4. Solte o conector do cabo do dispositivo de bloqueio da porta.

Reparação

5. Desaperte os parafusos pela ordem indicada.



6. Remova o painel frontal.

7. Desligue todas as ligações de mangueiras.

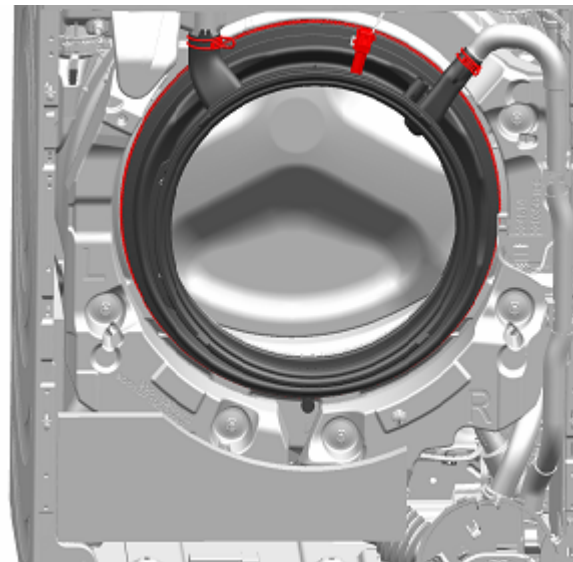

8. Remova a vedação da porta.

4.7.2 Instalar a vedação da porta

- ▶ Instale pela ordem inversa.

4.8 Substituir o dispositivo de bloqueio da porta

Na qualidade de fabricante, somos obrigados a fornecer aos consumidores um dispositivo de bloqueio da porta sobressalente incluindo as instruções de reparação de acordo com o Regulamento (UE) 2019/2023. Contudo, gostaríamos de salientar que após a substituição de um dispositivo de bloqueio da porta, é necessário um teste de segurança eletrotécnica realizado por um profissional qualificado antes de colocar o dispositivo em funcionamento. Tem de ser possível verificar a qualificação da pessoa em questão de acordo com as leis, regulamentos e normas específicas do país.

| | |
|--|--|
|  | ⚠ PERIGO |
| | Risco de choque elétrico devido a partes sob tensão! Risco de vida devido a choque elétrico em caso de reparação inadequada <ul style="list-style-type: none">▶ As partes elétricas devem ser reparadas por um electricista qualificado.▶ Após a reparação, solicite a realização de um teste de segurança de acordo com VDE 0701 ou os regulamentos específicos do país. |

| | |
|--|--|
|  | ⚠ CUIDADO |
| | Arestas vivas no alojamento! Lesões por corte <ul style="list-style-type: none">▶ Use luvas de proteção. |

| | |
|---|---|
|  | ⚠ AVISO |
| | Deslizamento de aparelhos inclinados! Fraturas ósseas / ferimentos de esmagamento <ul style="list-style-type: none">▶ Proteja os aparelhos contra o deslizamento. |

| | |
|--|---|
|  | ⚠ CUIDADO |
| | Risco de queda de peças devido a parafusos desapertados! Lesões devido à queda de peças. <ul style="list-style-type: none">▶ Proteja o componente contra as quedas. |

| | |
|--|--|
|  | ATENÇÃO! |
| | Risco de queda de peças devido a parafusos desapertados! Danos em outros componentes do aparelho ou na casa do cliente, p. ex., no pavimento. <ul style="list-style-type: none">▶ Proteja o componente contra as quedas. |

Pré-requisito:

- ✓ O aparelho está desligado da energia.
- ✓ O aparelho está desligado do abastecimento de água.
- ✓ O aparelho está livremente acessível.
- ✓ A frente do móvel foi removida.
- ✓ O painel da fachada foi removido.
- ✓ [A porta foi removida. → 368](#)
- ✓ O anel de tensão foi removido.
- ✓ O painel frontal foi removido.
- ✓ A vedação da porta foi removida.

4.8.1 Remover o dispositivo de bloqueio da porta

1. Desligue a ficha do dispositivo de bloqueio da porta.
2. Solte o dispositivo de bloqueio da porta.



3. Remova o dispositivo de bloqueio da porta.

4.8.2 Instalar o dispositivo de bloqueio da porta

O dispositivo de bloqueio da porta deve estar na posição correta para garantir a função de abertura de emergência da porta do aparelho.

- ▶ Instale pela ordem inversa.



4.9 Substituir a luz do tambor



CUIDADO

Arestas vivas no alojamento!
Lesões por corte
▶ Use luvas de proteção.



AVISO

Deslizamento de aparelhos inclinados!
Fraturas ósseas / ferimentos de esmagamento
▶ Proteja os aparelhos contra o deslizamento.



CUIDADO





Risco de queda de peças devido a parafusos desapertados!
Lesões devido à queda de peças.
▶ Proteja o componente contra as quedas.



ATENÇÃO!

Risco de queda de peças devido a parafusos desapertados!
Danos em outros componentes do aparelho ou na casa do cliente, p. ex., no pavimento.
▶ Proteja o componente contra as quedas.

Pré-requisito:

-  O aparelho está desligado da energia.
-  O aparelho está desligado do abastecimento de água.
-  O aparelho está livremente acessível.
-  [A gaveta para detergente foi removida. → 366](#)
-  O painel da fachada foi removido.

4.9.1 Remover a luz do tambor

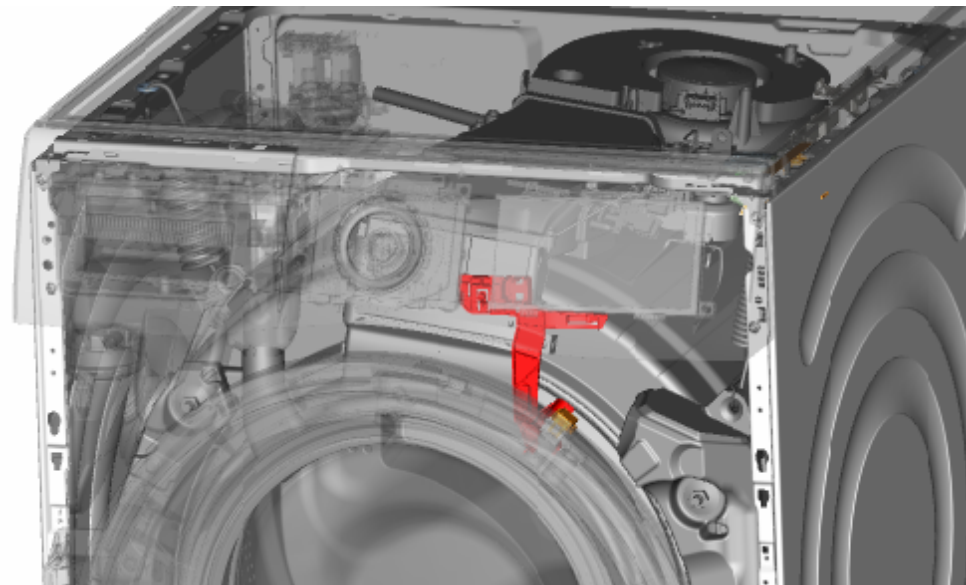

1. Puxe o suporte da luz do tambor para fora do aparelho.
2. Desligue as ligações elétricas.
3. Remova a luz do tambor do suporte da luz do tambor.

4.9.2 Instalar a luz do tambor

- ▶ Instale pela ordem inversa.

4.10 Substituir a tampa inferior



Fig. 1: Tampa do conjunto inferior

Pré-requisito:

- ✔ O aparelho está desligado da energia.
- ✔ O aparelho está desligado do abastecimento de água.
- ✔ A frente do móvel foi removida.

4.10.1 Remover a tampa inferior

Pré-requisito:

- ✔ O aparelho está desligado da energia.
 - ✔ O aparelho está desligado do abastecimento de água.
1. Remova a tampa inferior.

2. Desprenda a mangueira do suporte.

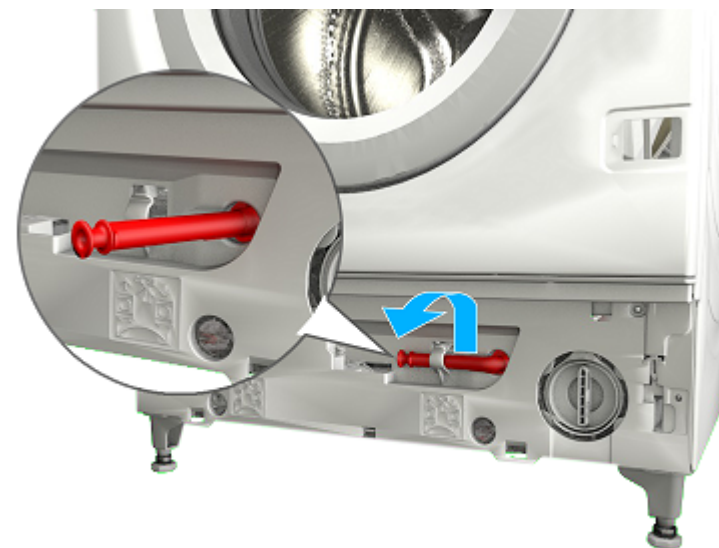

Reparação

3. 1. Desaperte o parafuso (1).
2. Pressione o ponto de retenção e remova para baixo (2).

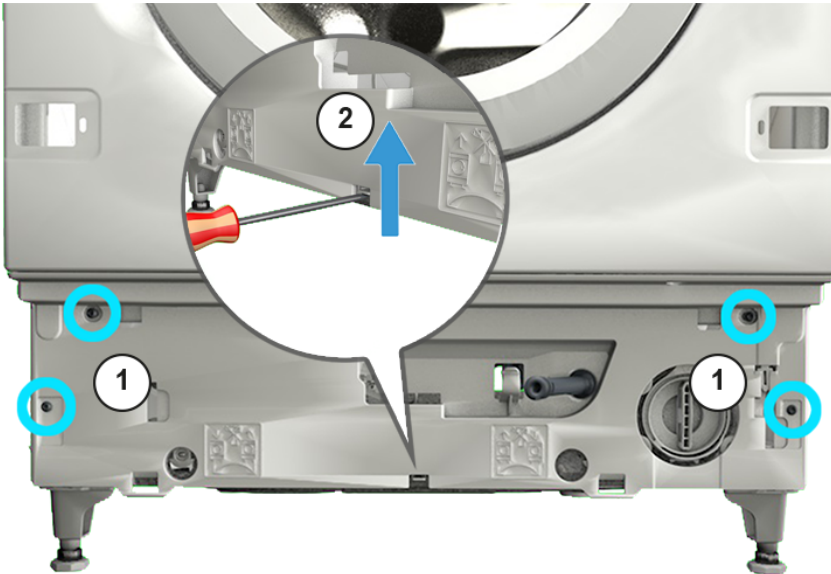

4. Puxe a tampa do conjunto inferior e remova para a frente.

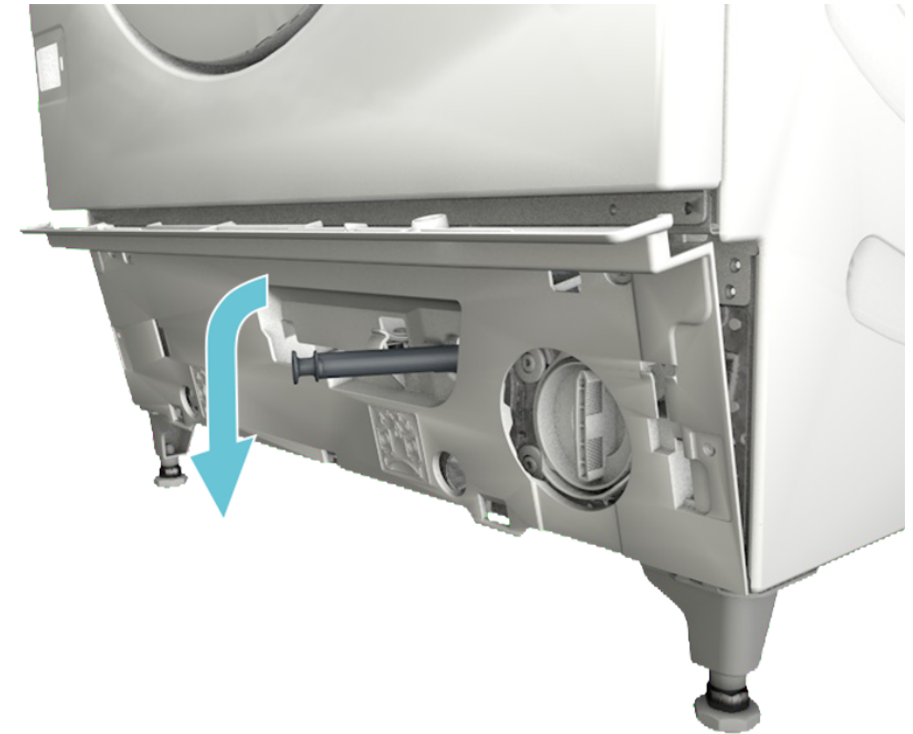

5. Puxe a mangueira para fora da tampa.

4.10.2 Instalar a tampa

- ▶ Instale pela ordem inversa.

4.11 Substituir o painel frontal

| | |
|--|--|
|  | ⚠️ CUIDADO Arestas vivas no alojamento! Lesões por corte ▶ Use luvas de proteção. |
|--|--|

Pré-requisito:

- ✔ O aparelho está desligado da energia.
- ✔ O aparelho está desligado do abastecimento de água.
- ✔ O aparelho está livremente acessível.
- ✔ [A gaveta para detergente foi removida. → 366](#)
- ✔ A frente do móvel foi removida.
- ✔ [A porta foi removida. → 368](#)
- ✔ A vedação da porta foi removida.

4.11.1 Remover o painel frontal

1. Desaperte o retentor da luz do tambor.

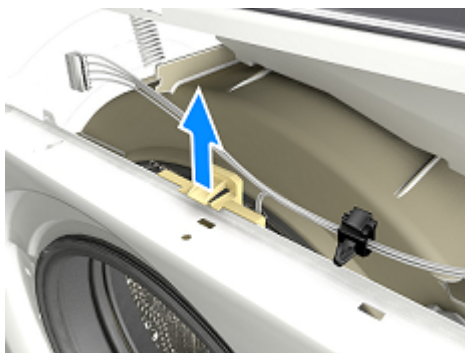

2.

| | |
|---|---|
|  | ⚠️ CUIDADO Risco de queda de peças devido a parafusos desapertados! Lesões devido à queda de peças. ▶ Proteja o componente contra as quedas. |
|---|---|

| | |
|---|--|
|  | ATENÇÃO! Risco de queda de peças devido a parafusos desapertados! Danos em outros componentes do aparelho ou na casa do cliente, p. ex., no pavimento. ▶ Proteja o componente contra as quedas. |
|---|--|

Desaperte os parafusos pela ordem indicada.



Reparação

3. Remova o painel frontal.

4.11.2 Instalar o painel frontal

▶ Instale pela ordem inversa.

Indicii pentru reparații - Mașină de spălat rufe

Referitor la acest document..... 381

| | | |
|-------|---------------------------------|-----|
| 1.1 | Informații importante | 381 |
| 1.1.1 | Aplicabilitatea | 381 |
| 1.2 | Explicația simbolurilor | 381 |
| 1.2.1 | Nivelurile de pericol | 381 |
| 1.2.2 | Simbolurile de pericol | 381 |
| 1.2.3 | Structura avertismentelor | 382 |
| 1.2.4 | Simbolurile generale | 382 |

Siguranța..... 383

| | | |
|-------|--|-----|
| 2.1 | Instrucțiuni generale de siguranță | 383 |
| 2.1.1 | Toate aparatele electrocasnice | 383 |

Instrumente și materiale utile..... 384

Repararea..... 385

| | | |
|-------|---|-----|
| 4.1 | Înlocuirea panoului de mascare | 385 |
| 4.1.1 | Demontarea panoului de mascare | 385 |
| 4.1.2 | Montarea panoului de mascare | 386 |
| 4.2 | Înlocuirea sertarului pentru detergent..... 387 | |
| 4.2.1 | Demontarea sertarului pentru detergent | 387 |
| 4.2.2 | Montarea sertarului pentru detergent..... 387 | |
| 4.3 | Înlocuirea mânerului sertarului pentru detergent | 388 |
| 4.3.1 | Demontarea mânerului sertarului pentru detergent..... 388 | |
| 4.3.2 | Montarea mânerului sertarului pentru detergent | 388 |
| 4.4 | Înlocuirea ușii | 389 |
| 4.4.1 | Demontarea ușii..... 389 | |
| 4.4.2 | Montarea ușii | 389 |
| 4.5 | Înlocuirea componentelor ușii | 390 |
| 4.5.1 | Demontarea componentelor ușii..... 390 | |
| 4.5.2 | Montarea componentelor ușii | 390 |
| 4.6 | Înlocuirea balamalei pentru ușă | 391 |
| 4.6.1 | Demontarea balamalei pentru ușă..... 391 | |
| 4.6.2 | Montarea balamalei pentru ușă | 391 |
| 4.7 | Înlocuirea garniturii ușii | 392 |
| 4.7.1 | Demontarea garniturii ușii..... 392 | |
| 4.7.2 | Montarea garniturii ușii | 393 |

| | | |
|--------|---|-----|
| 4.8 | Înlocuirea dispozitivului de blocare a ușii | 394 |
| 4.8.1 | Demontarea dispozitivului de blocare a ușii | 394 |
| 4.8.2 | Montarea dispozitivului de blocare a ușii | 395 |
| 4.9 | Înlocuirea iluminării cuvei..... 396 | |
| 4.9.1 | Demontarea iluminării cuvei | 396 |
| 4.9.2 | Montarea iluminării cuvei | 396 |
| 4.10 | Înlocuirea capacului inferior | 397 |
| 4.10.1 | Demontarea capacului inferior | 397 |
| 4.10.2 | Montarea capacului | 398 |
| 4.11 | Înlocuirea panoului frontal..... 399 | |
| 4.11.1 | Demontarea panoului frontal | 399 |
| 4.11.2 | Montarea panoului frontal..... 400 | |

i Referitor la acest document

1.1 Informații importante

1.1.1 Aplicabilitatea

Aceste instrucțiuni de reparare îl ajută pe client să își repare singur aparatele, în conformitate cu normele de proiectare ecologică aplicabile (începând cu 03/2021).





Acestea conțin informații privind modul de înlocuire a pieselor de schimb specifice, inclusiv avertismente și pericole.

Dacă aveți întrebări, vă rugăm să luați legătura cu serviciul relații clienți. Ne asumăm răspunderea pentru daune numai dacă instrucțiunile de reparare au fost respectate pe deplin.

1.2 Explicația simbolurilor

1.2.1 Nivelurile de pericol

Nivelurile de alertă sunt reprezentate printr-un simbol și un cuvânt de avertizare. Cuvântul de avertizare indică gravitatea pericolului.





| Nivelul de alertă | Semnificație |
|--|---|
|  PERICOL | Nerespectarea mesajului de avertizare va provoca accidente grave sau decesul. |
|  AVERTISMENT | Nerespectarea mesajului de avertizare ar putea provoca accidente grave sau decesul. |
|  ATENȚIONARE | Nerespectarea mesajului de avertizare ar putea provoca accidente ușoare. |
|  ATENȚIE! | Nerespectarea mesajului de avertizare ar putea provoca daune asupra proprietății. |

Tabel 1: Nivelurile de pericol



1.2.2 Simbolurile de pericol

Simbolurile de pericol sunt reprezentări simbolice care indică tipul de pericol.

În acest document sunt utilizate simbolurile de pericol de mai jos:

| Simbol de pericol | Semnificație |
|---|---------------------------------------|
|  | Mesaj de avertizare general |
|  | Pericol din cauza tensiunii electrice |
|  | Pericol de explozie |
|  | Pericol de tăiere |
|  | Pericol de zdrobire |

i Referitor la acest document

| Simbol de pericol | Semnificație |
|--|--|
|  | Pericol din cauza suprafețelor fierbinți |
|  | Pericol din cauza câmpului magnetic puternic |
|  | Pericol din cauza radiației neionizante |

Tabel 2: Simbolurile de pericol

1.2.3 Structura avertismentelor

Avertismentele din acest document au un aspect și o structură standard.



| | |
|--|--|
|  | <div style="background-color: red; color: white; padding: 2px; text-align: center;">⚠ PERICOL</div> <p>Tipul și sursa pericolului! Consecințele posibile ale ignorării pericolului/avertismentului.</p> <ul style="list-style-type: none"> ▶ Măsuri și interdicții pentru prevenirea pericolului. |
|--|--|









Exemplul următor prezintă un avertisment privind electrocutarea din cauza pieselor sub tensiune. Se menționează măsura necesară pentru a evita pericolul.

| | |
|---|---|
|  | <div style="background-color: red; color: white; padding: 2px; text-align: center;">⚠ PERICOL</div> <p>Pericol de electrocutare din cauza pieselor sub tensiune! Deces prin electrocutare</p> <ul style="list-style-type: none"> ▶ Deconectați aparatele de la sursa de alimentare cu tensiune cu cel puțin 60 de secunde înainte de a începe reparațiile. |
|---|---|

1.2.4 Simbolurile generale

În acest document sunt utilizate simbolurile generale de mai jos:

| Simbol general | Semnificație |
|--|---|
|  | Identificarea unei recomandări speciale (text și/sau grafică) |
|  | Identificarea unei recomandări simple (numai text) |

| Simbol general | Semnificație |
|---|---|
|  | Identificarea unui link spre un videoclip instructiv |
|  | Identificarea sculelor necesare |
|  | Identificarea condițiilor preliminare necesare |
|  | Identificarea unei stări (dacă..., apoi...) |
|  | Identificarea unui rezultat |
|  | Identificarea unei taste sau a unui buton |
|  | Identificarea unui număr de serie |
|  | Identificarea unui text/unei ferestre afișate (pe ecranul aparatului) |

Tabel 3: Simbolurile generale

2.1 Instrucțiuni generale de siguranță

2.1.1 Toate aparatele electrocasnice

Pericol de electrocutare din cauza pieselor sub tensiune!

- Erorile care au loc în timpul reparațiilor efectuate la componentele electrice pot să ducă la electrocutări!
- Deconectați aparatul de la sursa de alimentare cu tensiune cu cel puțin 60 de secunde înainte de a începe lucrările.
- După reparație, este obligatorie efectuarea unei verificări de siguranță conform cu VDE 0701 sau cu reglementările naționale respective.

Pericol de rănire din cauza muchiilor ascuțite!

- Purtați mănuși de protecție.

Pericol de zdrobire în timpul lucrărilor de reparație, întreținere, depanare și service, din cauza componentelor grele și mobile

- Purtați încălțăminte de protecție.
- Fixați componentele grele împotriva căderii.
- Nu vă sprijiniți cu părți ale corpului de componentele mobile.







Pericol pentru siguranța/funcționarea aparatului!





- Utilizați numai piese de schimb originale.

Pericol de deteriorare a componentelor sensibile la electricitatea statică (ESD)!

- Nu atingeți modulele, inclusiv conexiunile și căile conductorilor.

Instrumente și materiale utile

| Desemnare | Detalii | Imagini |
|--|---|--|
| Instrumentul auxiliar [15000155] | Instrument pentru slăbirea pieselor din plastic |  |
| Șurubelniță Torx T20 cu orificiu [00340764] | 100 mm, pentru șuruburi cu știft de siguranță |  |
| Cheie de cuplu [15000441] | Cheie de cuplu 20 - 100 Nm | |
| Șurubelniță cu slot [00340854] | Lamă 3,5 mm x 0,6 mm x 100 mm, Izolație protectoare 1000 V CA |  |
| Șurubelniță cu slot [00340855] | Lamă 5,5 mm x 1,0 mm x 125 mm, Izolație protectoare 1000 V CA |  |
| Clește cu cios, model unghiular [00341269] | Lungime 200 mm |  |
| Clește cu tăiere laterală [00342182] | Lungime: 200 mm |  |

| Desemnare | Detalii | Imagini |
|----------------------------------|-----------------------------|---|
| Cheie fixă inelară [00340811] | Dimensiune cheie 10°mm, M6 |  |
| Combination wrench [00340814] | Dimensiune cheie 13°mm, M8 |  |
| Cheie fixă inelară [00340817] | Dimensiune cheie 17 mm, M10 |  |
| Cheie fixă inelară [15000459] | Dimensiune cheie 16°mm, M10 |  |

4.1 Înlocuirea panoului de mascare



⚠️ ATENȚIONARE

Muchii ascuțiți ale carcasei!

Tăieturi

- ▶ Purtați mănuși de protecție.



⚠️ AVERTISMENT

Alunecarea aparatelor înclinate!

Fracturi/zdrobiri

- ▶ Fixați aparatele împotriva alunecării.



⚠️ ATENȚIONARE

Pericol din cauza pieselor care cad pentru că șuruburile sunt slăbite!

Accidente din cauza pieselor care cad.

- ▶ Fixați componenta împotriva căderii.



⚠️ ATENȚIE!

Pericol din cauza pieselor care cad pentru că șuruburile sunt slăbite!

Deteriorarea altor piese ale aparatului sau a casei clientului, de exemplu, partea de jos.

- ▶ Fixați componenta împotriva căderii.

Cerință:

- ✔️ Aparatul este deconectat de la sursa de energie electrică.
- ✔️ Aparatul este deconectat de la sursa de alimentare cu apă.
- ✔️ Aparatele sunt accesibile.
- ✔️ [Sertarul pentru detergent a fost demontat. →387](#)

4.1.1 Demontarea panoului de mascare

1. Decuplați elementul de prindere (1).
2. Scoateți capacul (2).

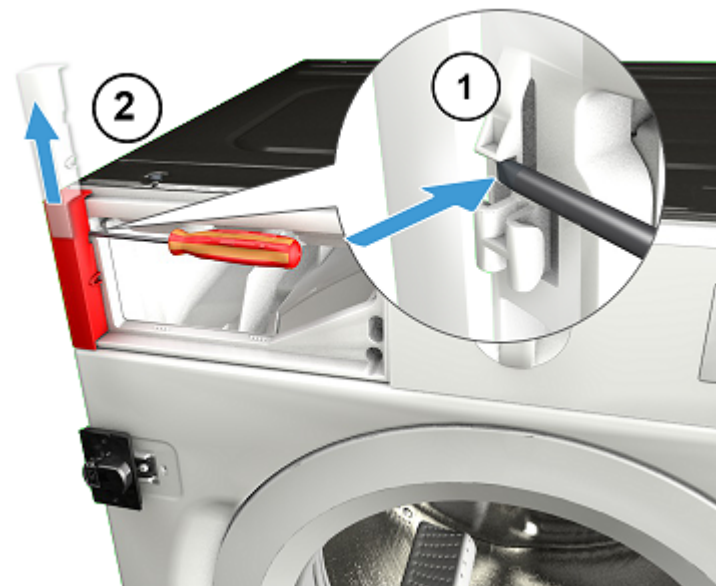

Repararea

2. Scoateți șuruburile.



3. 1. Decuplați elementele de prindere (1, 2).
2. Trageți panoul de mascare în față (3).

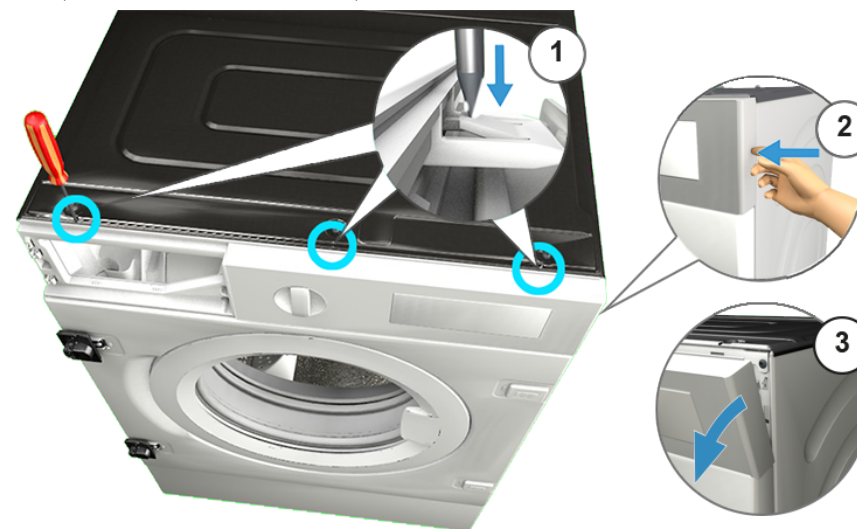

4. Demontați panoul de mascare.

4.1.2 Montarea panoului de mascare

► Montați urmând procedura de demontare în ordine inversă.

4.2 Înlocuirea sertarului pentru detergent

Cerință:

- ✓ Aparatul este deconectat de la sursa de energie electrică.
- ✓ Aparatul este deconectat de la sursa de alimentare cu apă.

4.2.1 Demontarea sertarului pentru detergent

1. Deschideți complet sertarul pentru detergent.
2. 1. Apăsați în jos pe inserție (1).
2. Scoateți sertarul pentru detergent (2).

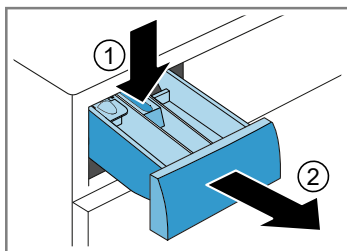

4.2.2 Montarea sertarului pentru detergent

- ▶ Montați urmând procedura de demontare în ordine inversă.

4.3 Înlocuirea mânerului sertarului pentru detergent

Cerință:

- ✓ Aparatul este deconectat de la sursa de energie electrică.
- ✓ Aparatul este deconectat de la sursa de alimentare cu apă.
- ✓ [Sertarul pentru detergent a fost demontat.](#)→387

4.3.1 Demontarea mânerului sertarului pentru detergent

1. Decuplați elementele de prindere.

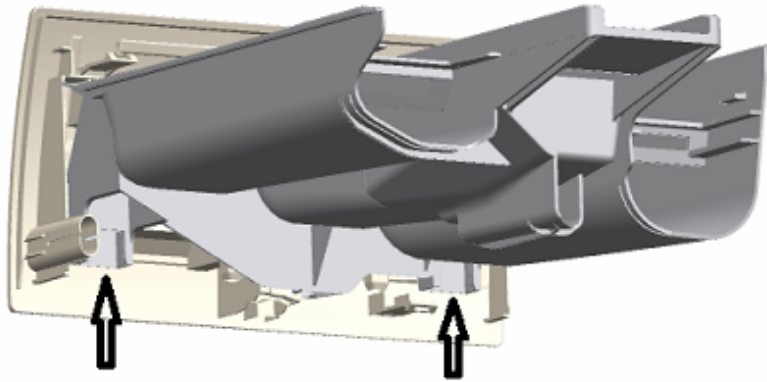

2. Scoateți mânerul sertarului pentru detergent.

4.3.2 Montarea mânerului sertarului pentru detergent

- ▶ Montați urmând procedura de demontare în ordine inversă.

4.4 Înlocuirea ușii



⚠️ ATENȚIONARE

Zona balamalei deschise!

Zdrobirea/prinderea degetelor

- ▶ Nu introduceți degetele sau mâna în zona balamalei.
- ▶ Purtați mănuși de protecție.

Cerință:

- ✔ Aparatul este deconectat de la sursa de energie electrică.
- ✔ Aparatul este deconectat de la sursa de alimentare cu apă.
- ✔ Ușa este deschisă.
- ✔ Placa de mobilier a fost demontată.

4.4.1 Demontarea ușii

1.



⚠️ ATENȚIE!

Pericol din cauza pieselor care cad pentru că șuruburile sunt slăbite!

Deteriorarea altor piese ale aparatului sau a casei clientului, de exemplu, partea de jos.

- ▶ Fixați componenta împotriva căderii.



⚠️ ATENȚIONARE

Pericol din cauza pieselor care cad pentru că șuruburile sunt slăbite!

Accidente din cauza pieselor care cad.

- ▶ Fixați componenta împotriva căderii.

Scoateți șuruburile (1).

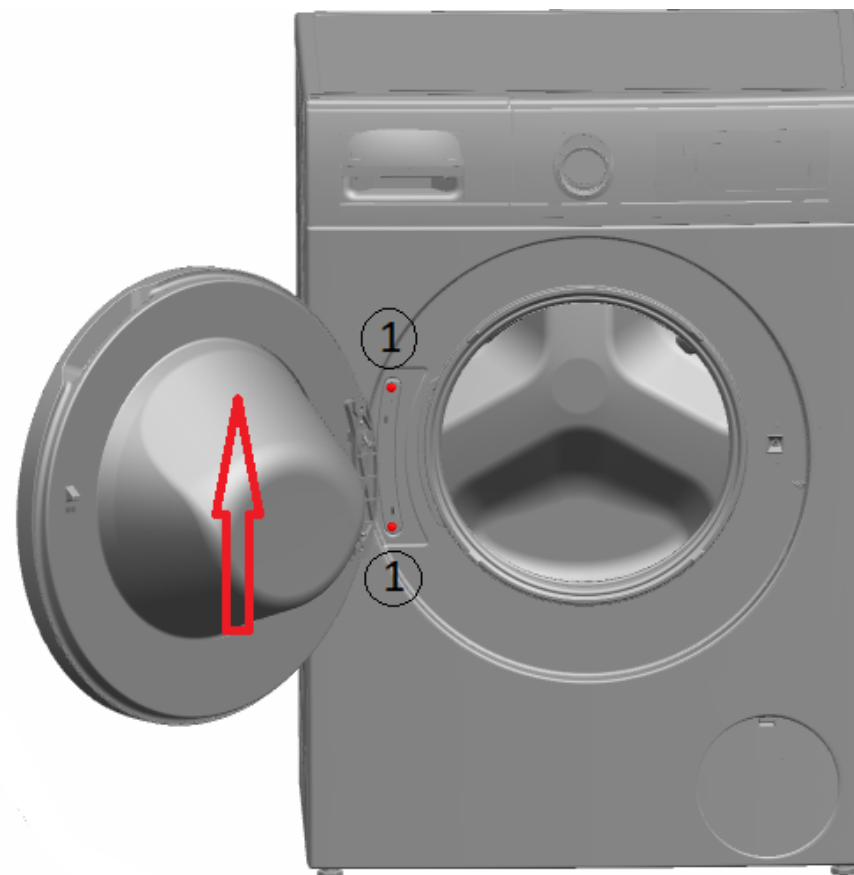

2. Scoateți ușa ridicând-o în sus.

4.4.2 Montarea ușii

- ▶ Montați urmând procedura de demontare în ordine inversă.

4.5 Înlocuirea componentelor ușii



ATENȚIONARE

Zona balamalei deschise!

Zdrobirea/prinderea degetelor

- ▶ Nu introduceți degetele sau mâna în zona balamalei.
- ▶ Purtați mănuși de protecție.

Cerință:

- ✓ Aparatul este deconectat de la sursa de energie electrică.
- ✓ Aparatul este deconectat de la sursa de alimentare cu apă.
- ✓ Placa de mobilier a fost demontată.
- ✓ [Ușa a fost demontată. → 389](#)

4.5.1 Demontarea componentelor ușii

- ▶ Dezasamblați ușa dinspre exterior înspre interior.

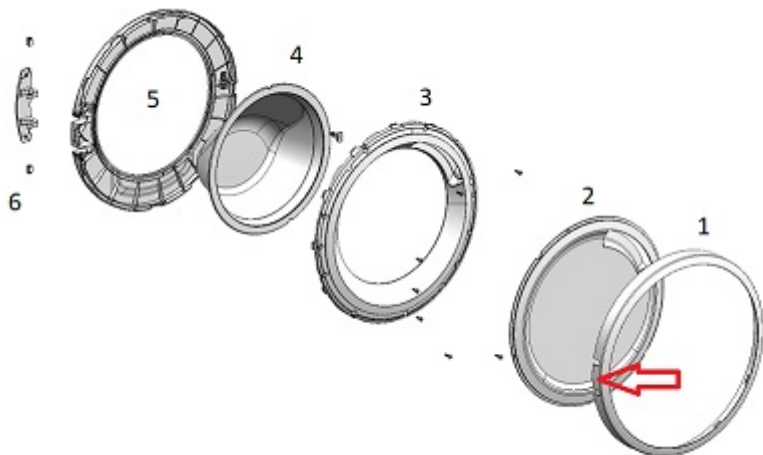

4.5.2 Montarea componentelor ușii

- ▶ Montați urmând procedura de demontare în ordine inversă.

4.6 Înlocuirea balamalei pentru ușă



ATENȚIONARE

Zona balamalei deschise!

Zdrobirea/prinderea degetelor

- ▶ Nu introduceți degetele sau mâna în zona balamalei.
- ▶ Purtați mănuși de protecție.

Cerință:

- ✓ Aparatul este deconectat de la sursa de energie electrică.
- ✓ Aparatul este deconectat de la sursa de alimentare cu apă.

4.6.1 Demontarea balamalei pentru ușă

1. Desfaceți două șuruburi.
2. Scoateți ușa.
3. Dezasamblați ușa dinspre exterior înspre interior.

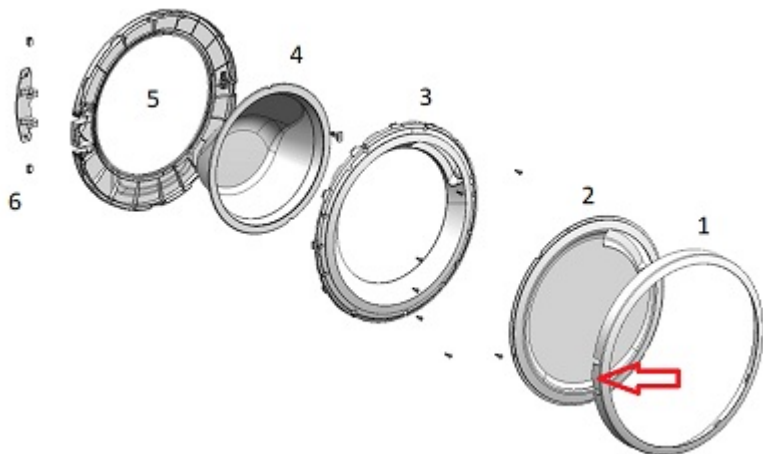



4. Demontați balamaua pentru ușă.

4.6.2 Montarea balamalei pentru ușă

- ▶ Montați urmând procedura de demontare în ordine inversă.

4.7 Înlocuirea garniturii ușii

| | |
|--|--|
|  | ATENȚIONARE Muchii ascuțiți ale carcasei! Tăieturi ▶ Purtați mănuși de protecție. |
|--|--|

| | |
|--|---|
|  | ATENȚIONARE Pericol din cauza pieselor care cad pentru că șuruburile sunt slăbite! Accidente din cauza pieselor care cad. ▶ Fixați componenta împotriva căderii. |
|--|---|

| | |
|--|--|
|  | ATENȚIE! Pericol din cauza pieselor care cad pentru că șuruburile sunt slăbite! Deteriorarea altor piese ale aparatului sau a casei clientului, de exemplu, partea de jos. ▶ Fixați componenta împotriva căderii. |
|--|--|

Cerință:

- ✔ Aparatul este deconectat de la sursa de energie electrică.
- ✔ Aparatul este deconectat de la sursa de alimentare cu apă.
- ✔ Aparatele sunt accesibile.
- ✔ [Sertarul pentru detergent a fost demontat.→387](#)
- ✔ Panoul de mascare a fost demontat.
- ✔ [Ușa a fost demontată.→389](#)
- ✔ [Capacul inferior a fost demontat.→397](#)

4.7.1 Demontarea garniturii ușii

1. Slăbiți dispozitivul de fixare a iluminării cuvei.



2.

| | |
|---|---|
|  | ATENȚIE! Pericol de suprafață deteriorată! Suprafața aparatului se poate zgâria dacă folosiți instrumentele greșite. ▶ Folosiți numai instrumente din plastic pentru a înlocui inelul de tensionare. |
|---|---|

Scoateți inelul de tensionare din garnitură cu un instrument din plastic.

3. Decuplați garnitura ușii de la panoul frontal.
4. Decuplați conectorul cablului de la dispozitivul de blocare a ușii.

Repararea

5. Slăbiți șuruburile în ordinea indicată.



6. Demontați panoul frontal.

7. Deconectați toate racordurile furtunurilor.

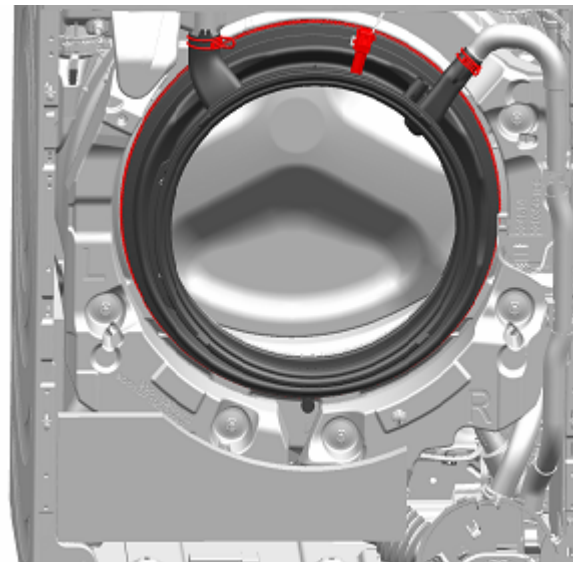

8. Scoateți garnitura ușii.

4.7.2 Montarea garniturii ușii

► Montați urmând procedura de demontare în ordine inversă.

4.8 Înlocuirea dispozitivului de blocare a ușii

În calitate de producător, suntem obligați să le oferim clienților piesa de schimb sistem de blocare pentru ușă, inclusiv instrucțiuni de reparare, în conformitate cu regulamentul (UE) 2019/2023. Am dori să subliniem însă, că, după înlocuirea sistemului de blocare a ușii, este obligatorie efectuarea unei verificări de siguranță electrotehnică de către un electrician calificat înainte ca dispozitivul să poată fi pus în funcțiune. Această persoană trebuie să fie calificată în mod certificabil în conformitate cu legile, reglementările și standardele naționale respective.

| | |
|--|--|
|  | ⚠ PERICOL |
| | <p>Pericol de electrocutare din cauza pieselor sub tensiune! Pericol de moarte prin electrocutare în cazul unei reparații necorespunzătoare</p> <ul style="list-style-type: none"> ▶ Componentele electrice trebuie reparate de către electricieni calificați. ▶ După reparație, este obligatorie efectuarea unei verificări de siguranță conform cu VDE 0701 sau cu reglementările naționale respective. |

| | |
|--|---|
|  | ⚠ ATENȚIONARE |
| | <p>Muchii ascuțiți ale carcasei! Tăieturi</p> <ul style="list-style-type: none"> ▶ Purtați mănuși de protecție. |

| | |
|---|---|
|  | ⚠ AVERTISMENT |
| | <p>Alunecarea aparatelor înclinate! Fracturi/zdrobiri</p> <ul style="list-style-type: none"> ▶ Fixați aparatele împotriva alunecării. |

| | |
|--|--|
|  | ⚠ ATENȚIONARE |
| | <p>Pericol din cauza pieselor care cad pentru că șuruburile sunt slăbite! Accidente din cauza pieselor care cad.</p> <ul style="list-style-type: none"> ▶ Fixați componenta împotriva căderii. |

| | |
|---|--|
|  | ATENȚIE! |
| | <p>Pericol din cauza pieselor care cad pentru că șuruburile sunt slăbite! Deteriorarea altor piese ale aparatului sau a casei clientului, de exemplu, partea de jos.</p> <ul style="list-style-type: none"> ▶ Fixați componenta împotriva căderii. |

Cerință:

- ✓ Aparatul este deconectat de la sursa de energie electrică.
- ✓ Aparatul este deconectat de la sursa de alimentare cu apă.
- ✓ Aparatele sunt accesibile.
- ✓ Placa de mobilier a fost demontată.
- ✓ Panoul de mascare a fost demontat.
- ✓ Ușa a fost demontată. → 389
- ✓ Inelul de tensionare a fost demontat.
- ✓ Panoul frontal a fost demontat.
- ✓ Garnitura ușii a fost demontată.

4.8.1 Demontarea dispozitivului de blocare a ușii

1. Deconectați fișa dispozitivului de blocare a ușii.
2. Decuplați dispozitivul de blocare a ușii.



3. Demontați dispozitivul de blocare a ușii.

4.8.2 Montarea dispozitivului de blocare a ușii

Pentru ca deschiderea de urgență a ușii aparatului să funcționeze corespunzător, dispozitivul de blocare a ușii trebuie să fie în poziția corectă.

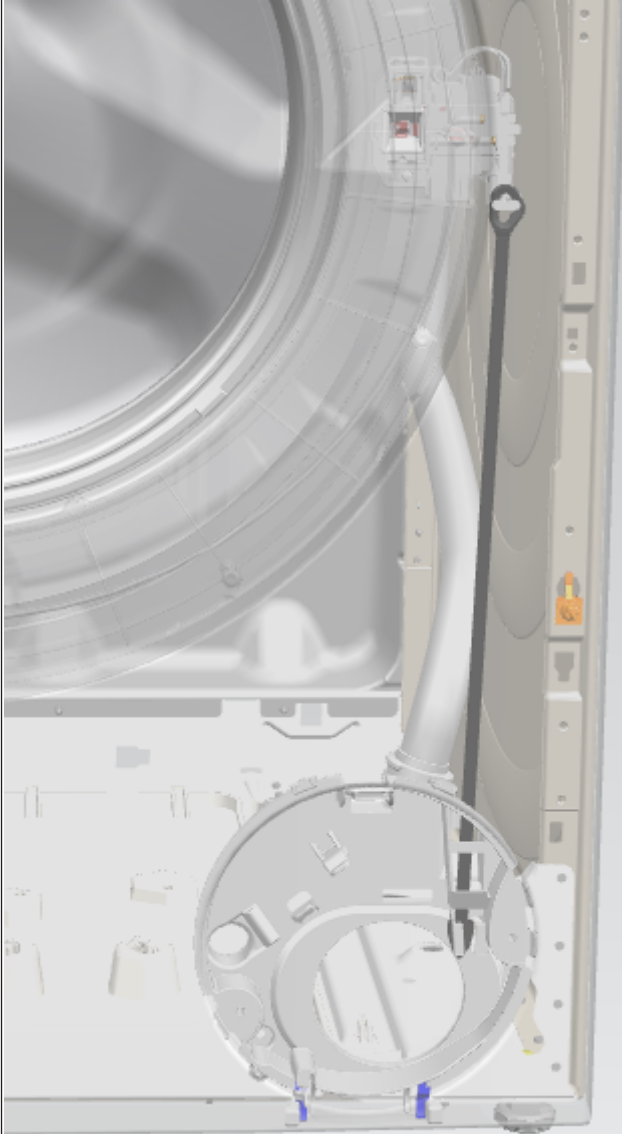

- ▶ Montați urmând procedura de demontare în ordine inversă.

4.9 Înlocuirea iluminării cuvei



⚠️ ATENȚIONARE

Muchii ascuțiți ale carcasei!
Tăieturi
▶ Purtați mănuși de protecție.



⚠️ AVERTISMENT

Alunecarea aparatelor înclinate!
Fracturi/zdrobiri
▶ Fixați aparatele împotriva alunecării.



⚠️ ATENȚIONARE

Pericol din cauza pieselor care cad pentru că șuruburile sunt slăbite!
Accidente din cauza pieselor care cad.
▶ Fixați componenta împotriva căderii.



⚠️ ATENȚIE!

Pericol din cauza pieselor care cad pentru că șuruburile sunt slăbite!
Deteriorarea altor piese ale aparatului sau a casei clientului, de exemplu, partea de jos.
▶ Fixați componenta împotriva căderii.

Cerință:

- ✔️ Aparatul este deconectat de la sursa de energie electrică.
- ✔️ Aparatul este deconectat de la sursa de alimentare cu apă.
- ✔️ Aparatele sunt accesibile.
- ✔️ [Sertarul pentru detergent a fost demontat. →387](#)
- ✔️ Panoul de mascare a fost demontat.

4.9.1 Demontarea iluminării cuvei

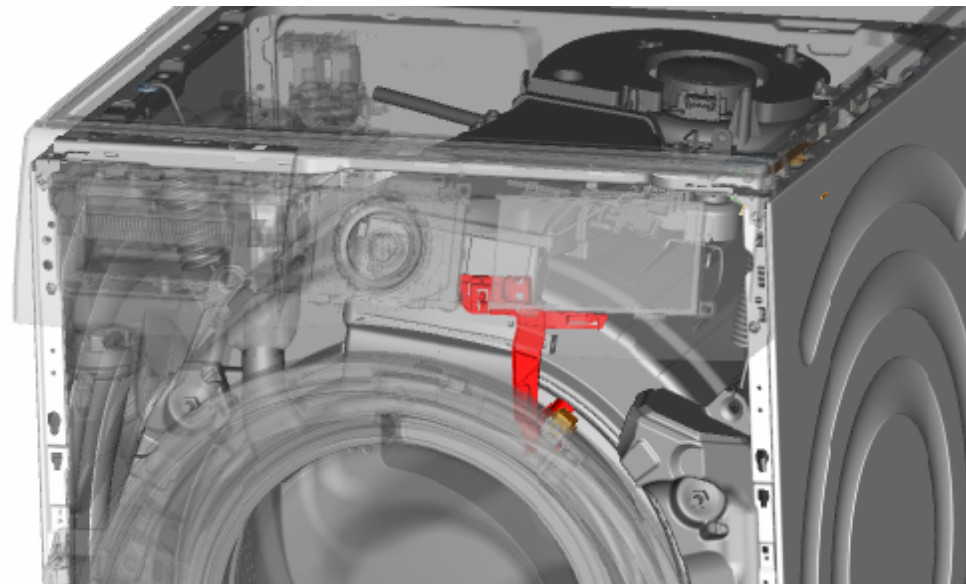

1. Trageți suportul iluminării cuvei afară din aparat.
2. Deconectați conexiunile electrice.
3. Demontați iluminarea cuvei din suport.

4.9.2 Montarea iluminării cuvei

- ▶ Montați urmând procedura de demontare în ordine inversă.

4.10 Înlocuirea capacului inferior



Fig. 1: Capacul grupului inferior

Cerință:

- ✓ Aparatul este deconectat de la sursa de energie electrică.
- ✓ Aparatul este deconectat de la sursa de alimentare cu apă.
- ✓ Placa de mobilier a fost demontată.

4.10.1 Demontarea capacului inferior

Cerință:

- ✓ Aparatul este deconectat de la sursa de energie electrică.
 - ✓ Aparatul este deconectat de la sursa de alimentare cu apă.
1. Scoateți capacul inferior.

2. Deconectați furtunul de la suport.

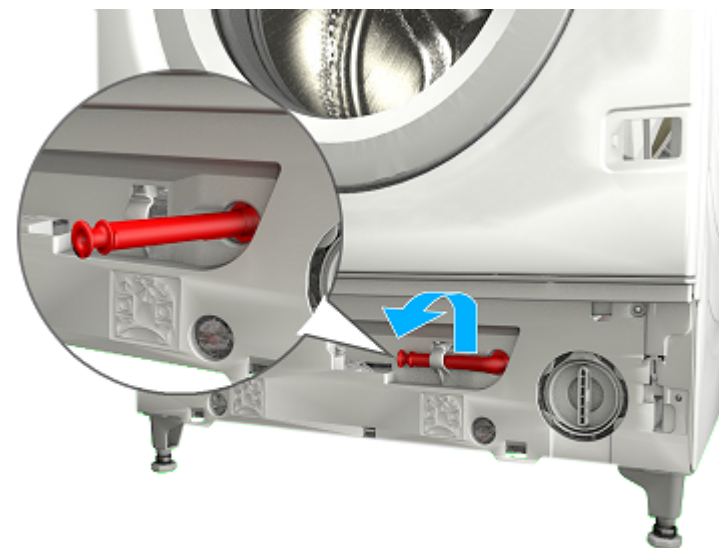

Repararea

3. 1. Desfaceți șurubul (1).
2. Apăsați pe punctul de fixare și scoateți în jos (2).

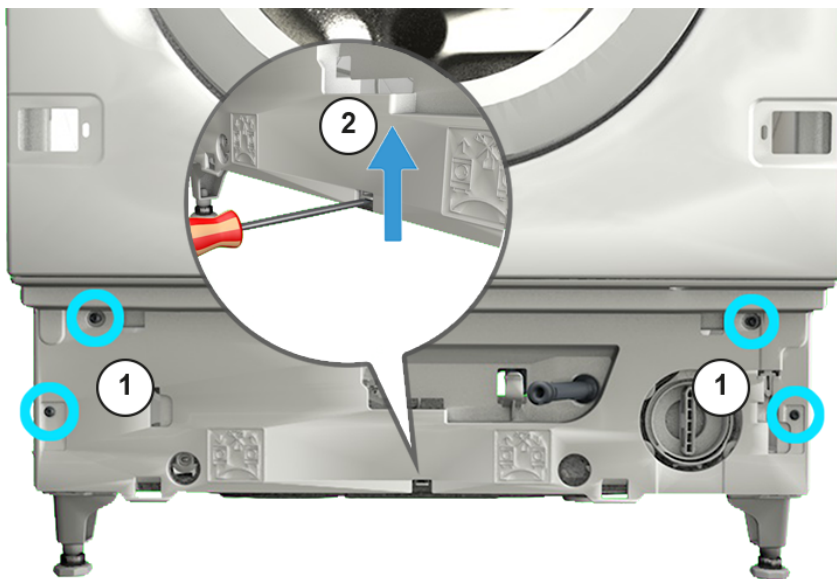

4. Trageți capacul grupului inferior și scoateți în față.



5. Scoateți furtunul de pe capac.

4.10.2 Montarea capacului

- ▶ Montați urmând procedura de demontare în ordine inversă.

4.11 Înlocuirea panoului frontal

| | |
|--|---|
|  | <p>⚠ ATENȚIONARE</p> <p>Muchii ascuțiți ale carcasei! Tăieturi</p> <ul style="list-style-type: none">▶ Purtați mănuși de protecție. |
|--|---|

Cerință:

- ✓ Aparatul este deconectat de la sursa de energie electrică.
- ✓ Aparatul este deconectat de la sursa de alimentare cu apă.
- ✓ Aparatele sunt accesibile.
- ✓ [Sertarul pentru detergent a fost demontat. →387](#)
- ✓ Placa de mobilier a fost demontată.
- ✓ [Ușa a fost demontată. →389](#)
- ✓ Garnitura ușii a fost demontată.

4.11.1 Demontarea panoului frontal

1. Slăbiți dispozitivul de fixare a iluminării cuvei.

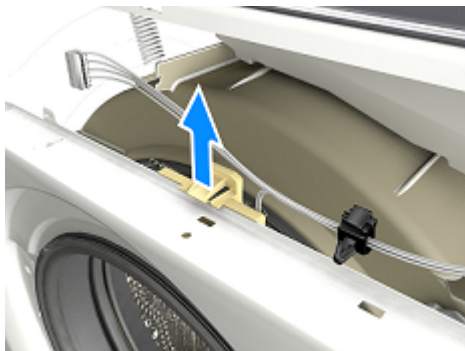

| | |
|---|--|
|  | <p>⚠ ATENȚIONARE</p> <p>Pericol din cauza pieselor care cad pentru că șuruburile sunt slăbite! Accidente din cauza pieselor care cad.</p> <ul style="list-style-type: none">▶ Fixați componenta împotriva căderii. |
|---|--|

| | |
|---|---|
|  | <p>ATENȚIE!</p> <p>Pericol din cauza pieselor care cad pentru că șuruburile sunt slăbite! Deteriorarea altor piese ale aparatului sau a casei clientului, de exemplu, partea de jos.</p> <ul style="list-style-type: none">▶ Fixați componenta împotriva căderii. |
|---|---|

Repararea

Slăbiți șuruburile în ordinea indicată.



3. Demontați panoul frontal.

4.11.2 Montarea panoului frontal

► Montați urmând procedura de demontare în ordine inversă.

Poznámky k opravám - Práčka

| | |
|--|------------|
|  O tomto dokumente | 402 |
| 1.1 Dôležité informácie | 402 |
| 1.1.1 Účel | 402 |
| 1.2 Vysvetlenie symbolov | 402 |
| 1.2.1 Úrovne nebezpečenstva | 402 |
| 1.2.2 Symboly označujúce riziká..... | 402 |
| 1.2.3 Štruktúra varovaní..... | 403 |
| 1.2.4 Všeobecné symboly | 403 |
|  Bezpečnosť | 404 |
| 2.1 Všeobecné bezpečnostné pokyny | 404 |
| 2.1.1 Všetky domáce spotrebiče..... | 404 |
|  Nástroje a pomôcky | 405 |
|  Oprava | 406 |
| 4.1 Výmena panelu obloženia | 406 |
| 4.1.1 Odstránenie panelu obloženia..... | 406 |
| 4.1.2 Montáž panelu obloženia..... | 407 |
| 4.2 Výmena zásuvky na prací prostriedok..... | 408 |
| 4.2.1 Odstránenie zásuvky na prací prostriedok | 408 |
| 4.2.2 Montáž zásuvky na prací prostriedok | 408 |
| 4.3 Výmena držadla zásuvky na prací prostriedok..... | 409 |
| 4.3.1 Odstránenie držadla zásuvky na prací prostriedok | 409 |
| 4.3.2 Montáž držadla zásuvky na prací prostriedok..... | 409 |
| 4.4 Výmena dverí | 410 |
| 4.4.1 Odoberanie dverí | 410 |
| 4.4.2 Montáž dverí..... | 410 |
| 4.5 Výmena komponentov dverí | 411 |
| 4.5.1 Odoberanie komponentov dverí | 411 |
| 4.5.2 Montáž komponentov dverí..... | 411 |
| 4.6 Výmena závesu dverí | 412 |
| 4.6.1 Odoberanie závesu dverí..... | 412 |
| 4.6.2 Montáž závesu dverí | 412 |
| 4.7 Výmena tesnenia dverí | 413 |
| 4.7.1 Odoberanie tesnenia dverí..... | 413 |
| 4.7.2 Montáž tesnenia dverí | 414 |

| | |
|--|-----|
| 4.8 Výmena poistky dvierok..... | 415 |
| 4.8.1 Odoberanie poistky dvierok | 415 |
| 4.8.2 Montáž poistky dvierok | 416 |
| 4.9 Výmena osvetlenia bubna | 417 |
| 4.9.1 Odoberanie osvetlenia bubna..... | 417 |
| 4.9.2 Montáž osvetlenia bubna | 417 |
| 4.10 Výmena spodného krytu | 418 |
| 4.10.1 Odoberanie spodného krytu | 418 |
| 4.10.2 Montáž krytu | 419 |
| 4.11 Výmena čelného panela | 420 |
| 4.11.1 Odstránenie čelného panela..... | 420 |
| 4.11.2 Montáž čelného panela | 421 |

i O tomto dokumente

1.1 Dôležité informácie

1.1.1 Účel

Tieto pokyny pre opravu pomáhajú spotrebiteľovi pri vlastnej oprave spotrebičov podľa nariadenia o ekodizajne (z marca 2021).

Obsahujú informácie o výmene určených náhradných dielov vrátane varovaní a rizík.

Ak máte otázky, kontaktujte náš zákaznícky servis. Za poškodenia ručíme len vtedy, ak pokyny boli dodržané správne.

1.2 Vysvetlenie symbolov

1.2.1 Úrovne nebezpečenstva

Úroveň varovania obsahuje symbol a signalizačné slovo. Signalizačné slovo naznačuje mieru nebezpečenstva.





| Úroveň varovania | Význam |
|---|---|
|  NEBEZPEČENSTVO | Následkom nerešpektovania varovného hlásenia je úmrtie alebo vážne zranenia. |
|  VAROVANIE | Možným následkom nerešpektovania varovného hlásenia je úmrtie alebo vážne zranenia. |
|  UPOZORNENIE | Možným následkom nerešpektovania varovného hlásenia sú mierne zranenia. |
|  POZOR! | Možným následkom nerešpektovania varovného hlásenia je poškodenie majetku. |

Tabuľka 1: Úrovne nebezpečenstva



1.2.2 Symboly označujúce riziká

Symboly označujúce riziká sú symbolické znázornenia, ktoré naznačujú druh nebezpečenstva.

V tomto dokumente sa používajú nasledujúce symboly označujúce riziká:

| Symbol označujúci riziko | Význam |
|---|---|
|  | Všeobecné varovné hlásenie |
|  | Nebezpečenstvo v súvislosti s elektrickým napätím |
|  | Nebezpečenstvo výbuchu |
|  | Nebezpečenstvo porezania |
|  | Nebezpečenstvo pomliaždenia |

i O tomto dokumente

| Symbol označujúci riziko | Význam |
|--|---|
|  | Nebezpečenstvo v súvislosti s horúcimi povrchmi |
|  | Nebezpečenstvo v súvislosti s magnetickým poľom |
|  | Nebezpečenstvo v súvislosti s neionizujúcou radiáciou |

Tabuľka 2: Symboly označujúce riziká

1.2.3 Štruktúra varovaní

Varovania v tomto dokumente majú štandardný vzhľad a štandardnú štruktúru.



| | |
|--|--|
|  | <p>⚠ NEBEZPEČENSTVO</p> <p>Druh a zdroj nebezpečenstva! Možné následky pri ignorovaní nebezpečenstva/varovania.</p> <ul style="list-style-type: none"> ▶ Opatrenia a zákazy na zabránenie nebezpečenstvu. |
|--|--|





Nasledujúci príklad znázorňuje varovanie pred zásahom elektrickým prúdom pri dotyku s časťami pod napätím. Je uvedené opatrenie na predídenie nebezpečenstvu.

| | |
|---|--|
|  | <p>⚠ NEBEZPEČENSTVO</p> <p>Nebezpečenstvo úrazu elektrickým prúdom pri dotyku s časťami pod napätím! Úmrtie v dôsledku zásahu elektrickým prúdom</p> <ul style="list-style-type: none"> ▶ Odpojte spotrebiče od elektrického zdroja aspoň 60 sekúnd pred začiatkom opráv. |
|---|--|

1.2.4 Všeobecné symboly

V tomto dokumente sa používajú nasledujúce všeobecné symboly:

| Všeob. symbol | Význam |
|--|---|
|  | Označenie špeciálneho pokynu (textové a/alebo grafické) |
|  | Označenie jednoduchého pokynu (len textové) |

| Všeob. symbol | Význam |
|---|---|
|  | Označenie prepojenia na videonávod |
|  | Označenie požadovaných nástrojov |
|  | Označenie požadovaných podmienok |
|  | Označenie podmienky (ak ..., potom ...) |
|  | Označenie výsledku |
| [Spustenie] | Označenie klávesu alebo tlačidla |
| [00123456] | Označenie čísla materiálu |
| Stav | Označenie zobrazeného textu/okna (na displeji spotrebiča) |

Tabuľka 3: Všeobecné symboly

2.1 Všeobecné bezpečnostné pokyny

2.1.1 Všetky domáce spotrebiče

Nebezpečenstvo úrazu elektrickým prúdom pri dotyku s časťami pod napätím!

- Chyby pri opravách na elektrických komponentoch môžu spôsobiť zásah elektrickým prúdom!
- Odpojte spotrebič od elektrickej siete aspoň 60 sekúnd pred začiatkom práce.
- Po oprave zariadenia vykonajte bezpečnostný test v súlade s nariadením VDE 0701 alebo s miestnymi nariadeniami.

Riziko poranenia na ostrých hranách!

- Noste ochranné rukavice.

Riziko pomliaždenia počas opravy, údržby, riešenia problémov a servisu na ťažkých a pohybujúcich sa komponentoch

- Noste ochrannú obuv.
- Zaisťujte ťažké komponenty proti pádu.
- Nesiahajte končatinami do pohybujúcich sa komponentov.







Riziko ohrozenia bezpečnosti/funkčnosti spotrebiča!





- Používajte len originálne náhradné diely.

Riziko poškodenia elektrostaticky citlivých komponentov (ESD)!

- Nedotýkajte sa modulov vrátane prípojok a vedení vodičov.

Nástroje a pomôcky

| Označenie | Detaily | Snímky |
|---|--|--|
| Pomocný nástroj [15000155] | Nástroj na uvoľnenie plastových častí |  |
| Skrutkovač Torx T20 s otvorom [00340764] | 100 mm, pre skrutky s bezpečnostným čapom |  |
| Momentový kľúč [15000441] | Momentový kľúč 20 – 100 Nm | |
| Plochý skrutkovač [00340854] | Čepeľ 3,5 mm x 0,6 mm x 100 mm, ochranná izolácia 1000 V AC |  |
| Plochý skrutkovač [00340855] | Čepeľ 5,5 mm x 1,0 mm x 125 mm, ochranná izolácia 1 000 V AC |  |
| Kliešte zahnuté, špicaté [00341269] | Dĺžka 200 mm |  |
| Bočné štípacie kliešte [00342182] | Dĺžka: 200 mm |  |

| Označenie | Detaily | Snímky |
|----------------------------------|--------------------------|---|
| Kombinovaný kľúč [00340811] | Veľkosť kľúča 10°mm, M6 |  |
| Combination wrench [00340814] | Veľkosť kľúča 13°mm, M8 |  |
| Kombinovaný kľúč [00340817] | Veľkosť kľúča 17 mm, M10 |  |
| Kombinovaný kľúč [15000459] | Veľkosť kľúča 16°mm, M10 |  |

4.1 Výmena panelu obloženia



UPOZORNENIE

Ostré hrany plášt'a!
Rezné poranenia
▶ Noste ochranné rukavice.



VAROVANIE

Zošmyknutie naklonených spotrebičov!
Zlomeniny/pomliaždenia
▶ Zaistite spotrebiče proti zošmyknutiu.



UPOZORNENIE

Riziko pádu dielov po uvoľnení skrutiek!
Zranenie padajúcimi dielmi.
▶ Zaistite komponent proti pádu.



POZOR!

Riziko pádu dielov po uvoľnení skrutiek!
Poškodenie iných častí spotrebiča alebo domácnosti zákazníka, napr. podlahy.
▶ Zaistite komponent proti pádu.

Požiadavka:

- ✔ Spotrebič je odpojený od elektrického napájania.
- ✔ Spotrebič je odpojený od zdroja vody.
- ✔ Spotrebič je voľne dostupný.
- ✔ [Zásuvka na prací prostriedok bola odobratá.→408](#)

4.1.1 Odstránenie panelu obloženia

1. Uvoľnite zachytávací prvok (1).
2. Odoberte kryt (2).

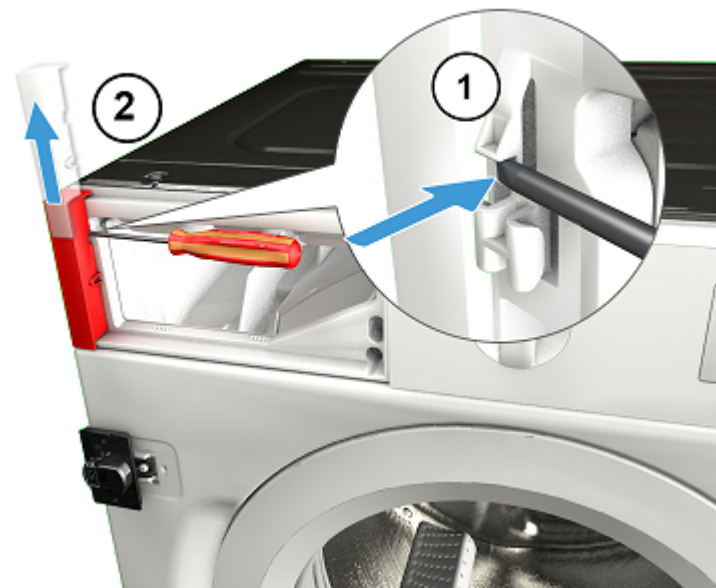

2. Odstráňte skrutky.



3. 1. Uvoľnite zachytávacie prvky (1, 2).
2. Zatlačte čelný panel dopredu (3).

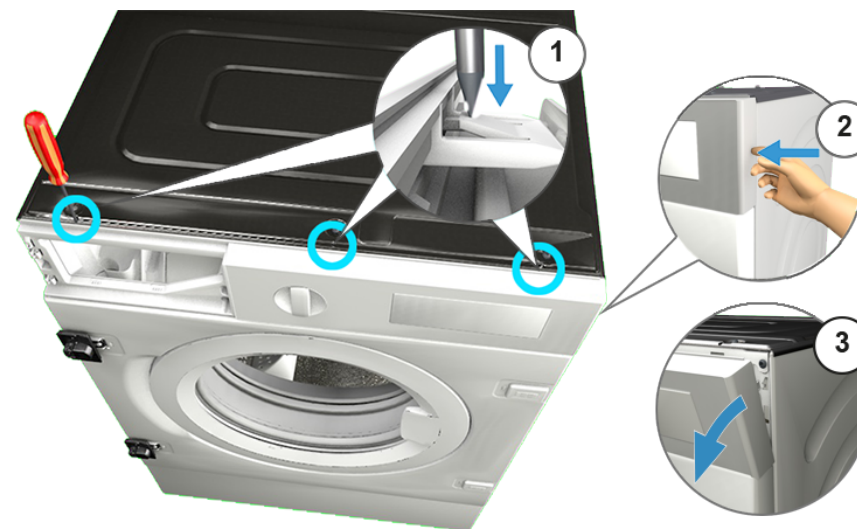

4. Odoberte panel obloženia.

4.1.2 Montáž panelu obloženia

► Pri montáži postupujte v opačnom poradí krokov demontáže.

4.2 Výmena zásuvky na prací prostriedok

Požiadavka:

- ✔ Spotrebič je odpojený od elektrického napájania.
- ✔ Spotrebič je odpojený od zdroja vody.

4.2.1 Odstránenie zásuvky na prací prostriedok

1. Vytiahnite zásuvku na prací prostriedok.
2. 1. Zatlačte na vložku (1).
2. Odoberte zásuvku na prací prostriedok (2).

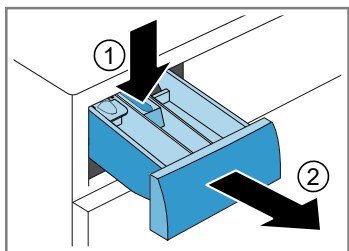

4.2.2 Montáž zásuvky na prací prostriedok

- ▶ Pri montáži postupujte v opačnom poradí krokov demontáže.

4.3 Výmena držadla zásuvky na prací prostriedok

Požiadavka:

- ✔ Spotrebič je odpojený od elektrického napájania.
- ✔ Spotrebič je odpojený od zdroja vody.
- ✔ [Zásuvka na prací prostriedok bola odobratá.→408](#)

4.3.1 Odstránenie držadla zásuvky na prací prostriedok

1. Uvoľnite zachytávacie prvky.

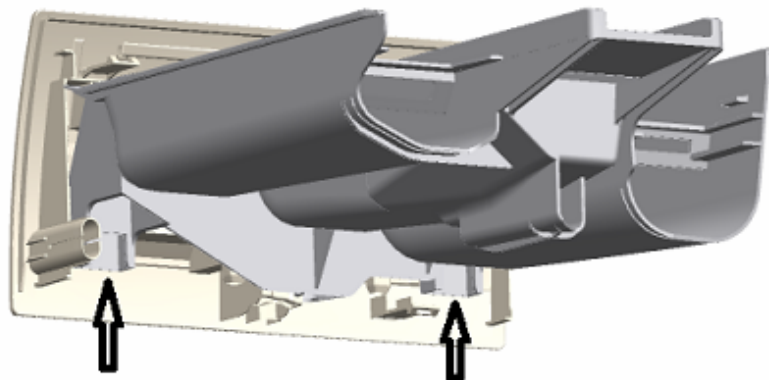

2. Odoberte držadlo zásuvky na prací prostriedok.

4.3.2 Montáž držadla zásuvky na prací prostriedok

- ▶ Pri montáži postupujte v opačnom poradí krokov demontáže.

4.4 Výmena dverí

| | |
|--|--|
|  | UPOZORNENIE Otvorte oblasť závesov! Pomliaždenie/zachytenie prstov ▶ Nesiahajte do priestoru závesov. ▶ Noste ochranné rukavice. |
|--|--|

Požiadavka:

- ✔ Spotrebič je odpojený od elektrického napájania.
- ✔ Spotrebič je odpojený od zdroja vody.
- ✔ Dvere sú otvorené.
- ✔ Čelo nábytku bolo odobraté.

4.4.1 Odoberanie dverí

1.

| | |
|---|--|
|  | POZOR! Riziko pádu dielov po uvoľnení skrutiek! Poškodenie iných častí spotrebiča alebo domácnosti zákazníka, na- pr. podlahy. ▶ Zaisťujte komponent proti pádu. |
|---|--|

| | |
|--|---|
|  | UPOZORNENIE Riziko pádu dielov po uvoľnení skrutiek! Zranenie padajúcimi dielmi. ▶ Zaisťujte komponent proti pádu. |
|--|---|

Odstráňte skrutky (1).

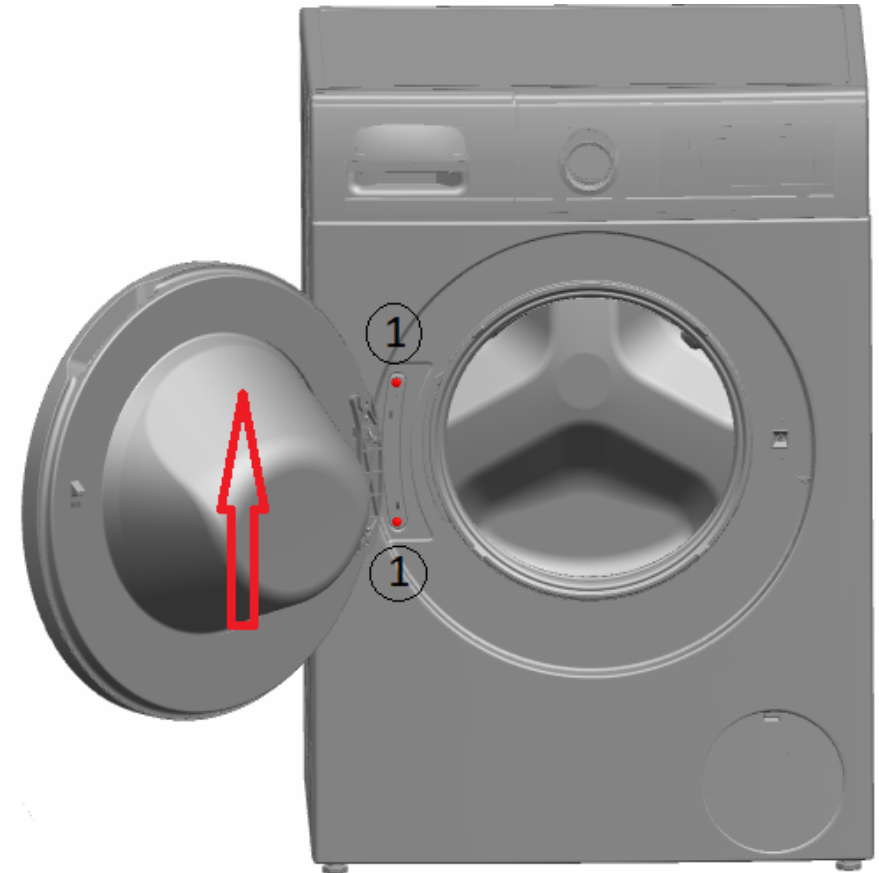

2. Odoberte dvere smerom nahor.

4.4.2 Montáž dverí

- ▶ Pri montáži postupujte v opačnom poradí krokov demontáže.

4.5 Výmena komponentov dverí



UPOZORNENIE

Otvorte oblasť závesov!

Pomliaždenie/zachytenie prstov

- ▶ Nesiahajte do priestoru závesov.
- ▶ Noste ochranné rukavice.

Požiadavka:

- ✔ Spotrebič je odpojený od elektrického napájania.
- ✔ Spotrebič je odpojený od zdroja vody.
- ✔ Čelo nábytku bolo odobraté.
- ✔ [Dvere boli odobraté.→410](#)

4.5.1 Odoberanie komponentov dverí

- ▶ Odmontujte dvere zvonku do vnútra.

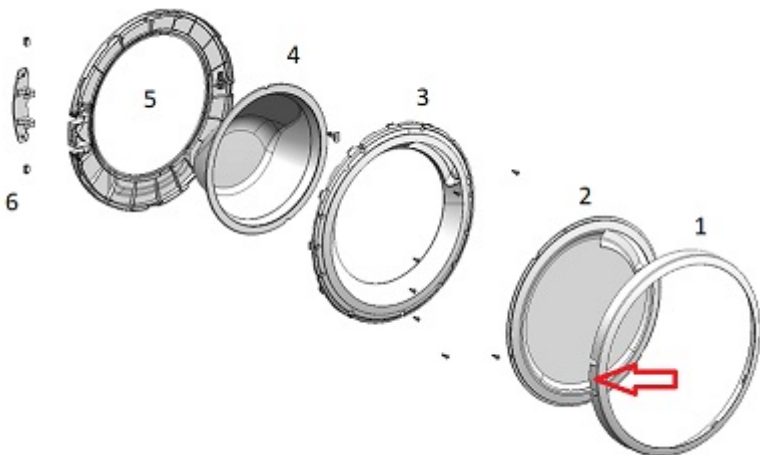

4.5.2 Montáž komponentov dverí

- ▶ Pri montáži postupujte v opačnom poradí krokov demontáže.

4.6 Výmena závesu dverí



UPOZORNENIE

Otvorte oblasť závesov!

Pomliaždenie/zachytenie prstov

- ▶ Nesiahajte do priestoru závesov.
- ▶ Noste ochranné rukavice.

Požiadavka:

- ✔ Spotrebič je odpojený od elektrického napájania.
- ✔ Spotrebič je odpojený od zdroja vody.

4.6.1 Odoberanie závesu dverí

1. Uvoľnite dve skrutky.
2. Odoberte dvere.
3. Odmontujte dvere zvonku do vnútra.

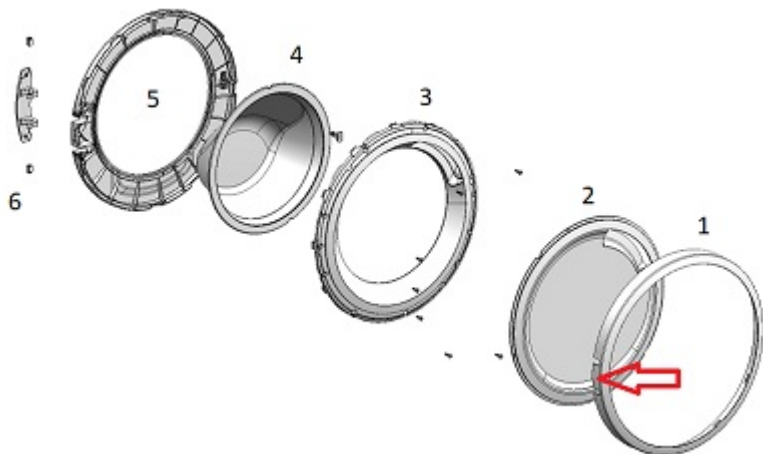

4. Odoberte záves dverí.

4.6.2 Montáž závesu dverí

- ▶ Pri montáži postupujte v opačnom poradí krokov demontáže.

4.7 Výmena tesnenia dverí



UPOZORNENIE

Ostré hrany plášt'a!
Rezné poranenia
▶ Noste ochranné rukavice.



UPOZORNENIE

Riziko pádu dielov po uvoľnení skrutiek!
Zranenie padajúcimi dielmi.
▶ Zaistite komponent proti pádu.



POZOR!

Riziko pádu dielov po uvoľnení skrutiek!
Poškodenie iných častí spotrebiča alebo domácnosti zákazníka, napr. podlahy.
▶ Zaistite komponent proti pádu.

Požiadavka:

- ✔ Spotrebič je odpojený od elektrického napájania.
- ✔ Spotrebič je odpojený od zdroja vody.
- ✔ Spotrebič je voľne dostupný.
- ✔ [Zásuvka na prací prostriedok bola odobratá.→408](#)
- ✔ Panel obloženia bol odobratý.
- ✔ [Dvere boli odobraté.→410](#)
- ✔ [Spodný kryt bol odobratý.→418](#)

4.7.1 Odoberanie tesnenia dverí

1. Uvoľnite držiak na svetidle bubna.



- 2.



POZOR!

Riziko poškodenia povrchu!
Použitím nesprávnych nástrojov sa povrch spotrebiča môže poškríabať.
▶ Na výmenu napínacieho krúžka použite len plastové nástroje.

Odoberte napínací krúžok z tesnenia použitím plastového nástroja.

3. Uvoľnite tesnenie dverí z čelného panela.
4. Uvoľnite káblovú prípojku z poistky dvierok.

5. Uvoľnite skrutky v naznačenom poradí.



6. Odoberte čelný panel.

7. Odpojte všetky hadicové pripojenia.

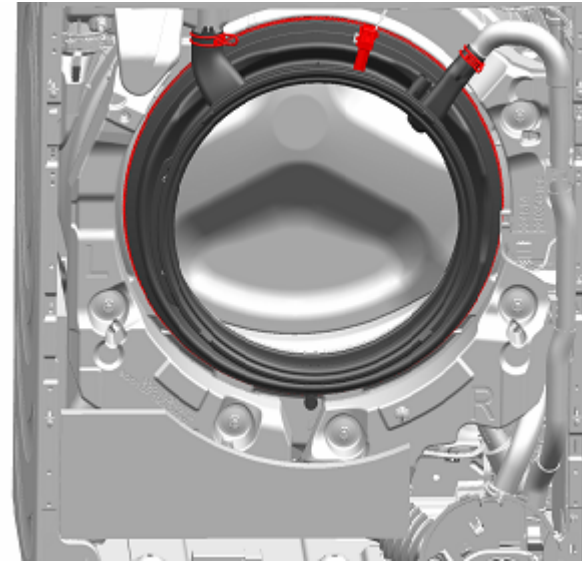

8. Odoberte tesnenie dverí.

4.7.2 Montáž tesnenia dverí

► Pri montáži postupujte v opačnom poradí krokov demontáže.

4.8 Výmena poistky dvierok

Ako výrobca sme povinní poskytnúť zákazníkovi náhradný diel – poistka dvierok - vrátane pokynov k oprave v súlade s nariadením (EÚ) 2019/2023. Chceli by sme však podotknúť, že po výmene poistky dvierok sa pred uvedením spotrebiča do prevádzky vyžaduje test elektrotechnickej bezpečnosti, ktorý vykoná kvalifikovaný elektrikár. Kvalifikáciu tejto osoby musí byť možné overiť podľa miestnych zákonov, regulácií a nariadení.

| | |
|--|--|
|  | ⚠ NEBEZPEČENSTVO |
| | <p>Nebezpečenstvo úrazu elektrickým prúdom pri dotyku s časťami pod napätím! Ohrozenie života spôsobené elektrickým zásahom v prípade nesprávnej opravy</p> <ul style="list-style-type: none"> ▶ Elektrické diely má opravovať kvalifikovaný elektrikár. ▶ Po oprave zariadenie vykonať bezpečnostný test v súlade s nariadením VDE 0701 alebo s miestnymi nariadeniami. |

| | |
|--|---|
|  | ⚠ UPOZORNENIE |
| | <p>Ostré hrany plášťa! Rezné poranenia</p> <ul style="list-style-type: none"> ▶ Noste ochranné rukavice. |

| | |
|---|---|
|  | ⚠ VAROVANIE |
| | <p>Zošmyknutie naklonených spotrebičov! Zlomeniny/pomliaždenia</p> <ul style="list-style-type: none"> ▶ Zaistíte spotrebiče proti zošmyknutiu. |

| | |
|--|--|
|  | ⚠ UPOZORNENIE |
| | <p>Riziko pádu dielov po uvoľnení skrutiek! Zranenie padajúcimi dielmi.</p> <ul style="list-style-type: none"> ▶ Zaistíte komponent proti pádu. |

| | |
|--|---|
|  | POZOR! |
| | <p>Riziko pádu dielov po uvoľnení skrutiek! Poškodenie iných častí spotrebiča alebo domácnosti zákazníka, napr. podlahy.</p> <ul style="list-style-type: none"> ▶ Zaistíte komponent proti pádu. |

Požiadavka:

- ✔ Spotrebič je odpojený od elektrického napájania.
- ✔ Spotrebič je odpojený od zdroja vody.
- ✔ Spotrebič je voľne dostupný.
- ✔ Čelo nábytku bolo odobraté.
- ✔ Panel obloženia bol odobratý.
- ✔ Dvere boli odobraté. → 410
- ✔ Napínací krúžok bol odobratý.
- ✔ Čelný panel bol odobratý.
- ✔ Tesnenie dverí boli odobraté.

4.8.1 Odoberanie poistky dvierok

1. Odpojte zástrčku poistky dvierok.
2. Uvoľnite poistku dvierok.



3. Odoberte poistku dvierok.



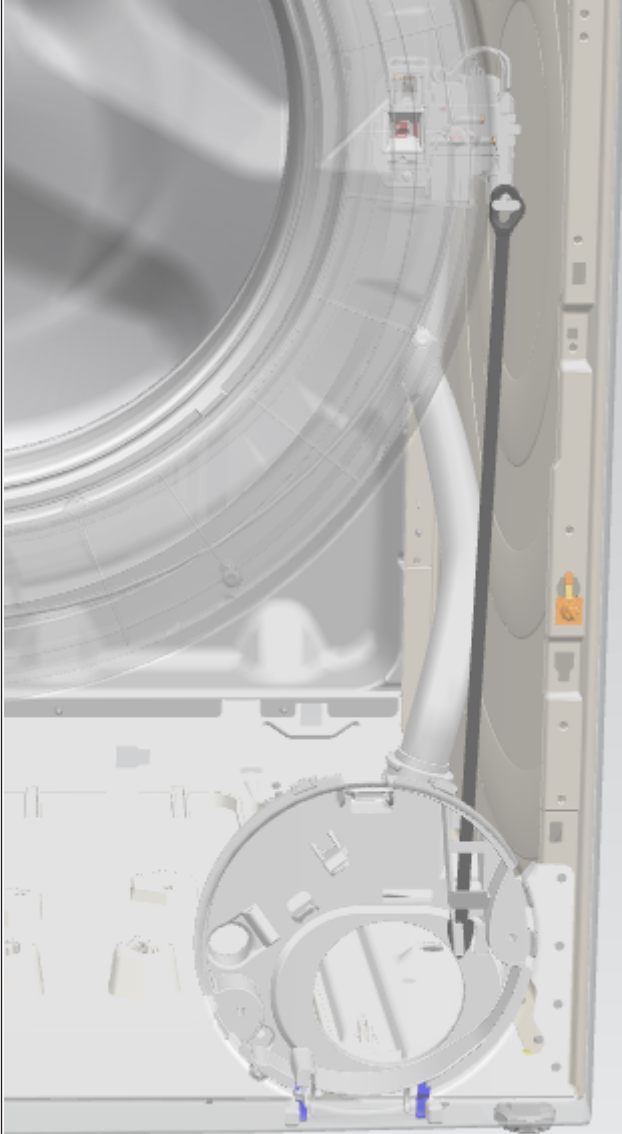

4.8.2 Montáž poistky dvierok

Poistka dvierok musí byť v správnej polohe, aby bola zabezpečená funkcia núdzového otvárania dvierok spotrebiča.



- ▶ Pri montáži postupujte v opačnom poradí krokov demontáže.

4.9 Výmena osvetlenia bubna

| | |
|--|--|
|  | UPOZORNENIE Ostré hrany plášťa! Rezné poranenia ▶ Noste ochranné rukavice. |
|  | VAROVANIE Zošmyknutie naklonených spotrebičov! Zlomeniny/pomliaždenia ▶ Zaistite spotrebiče proti zošmyknutiu. |
|  | UPOZORNENIE Riziko pádu dielov po uvoľnení skrutiek! Zranenie padajúcimi dielmi. ▶ Zaistite komponent proti pádu. |
|  | POZOR! Riziko pádu dielov po uvoľnení skrutiek! Poškodenie iných častí spotrebiča alebo domácnosti zákazníka, napr. podlahy. ▶ Zaistite komponent proti pádu. |

Požiadavka:

- ✔ Spotrebič je odpojený od elektrického napájania.
- ✔ Spotrebič je odpojený od zdroja vody.
- ✔ Spotrebič je voľne dostupný.
- ✔ [Zásuvka na prací prostriedok bola odobratá.→408](#)
- ✔ Panel obloženia bol odobratý.

4.9.1 Odoberanie osvetlenia bubna

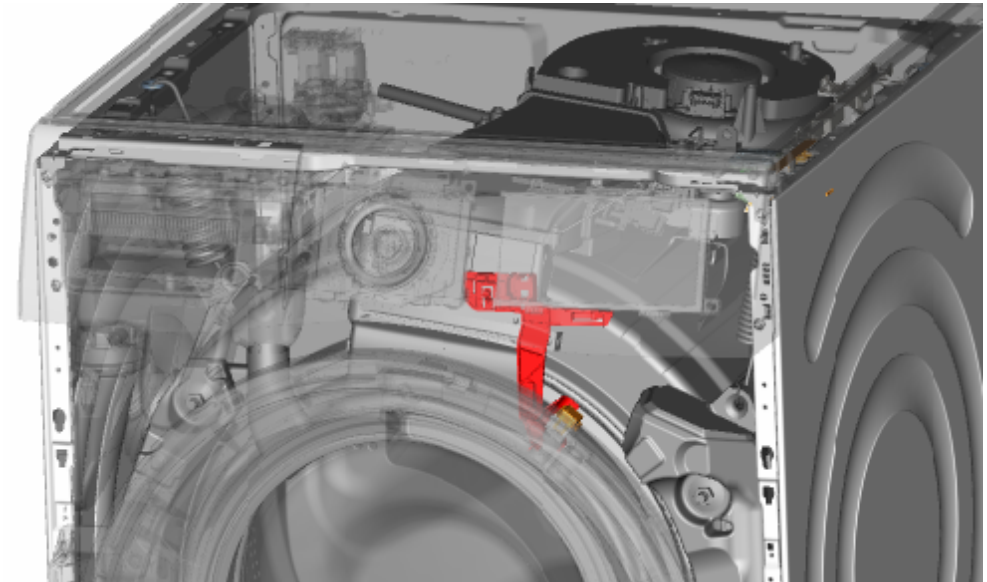

1. Vytiahnite držiak osvetlenia bubna spotrebiča.
2. Odpojte elektrické pripojenia.
3. Odoberte osvetlenie bubna z držiaka osvetlenia bubna.

4.9.2 Montáž osvetlenia bubna

- ▶ Pri montáži postupujte v opačnom poradí krokov demontáže.

4.10 Výmena spodného krytu



Obr. 1: Spoločný spodný kryt

Požiadavka:

- ✔ Spotrebič je odpojený od elektrického napájania.
- ✔ Spotrebič je odpojený od zdroja vody.
- ✔ Čelo nábytku bolo odobraté.

4.10.1 Odoberanie spodného krytu

Požiadavka:

- ✔ Spotrebič je odpojený od elektrického napájania.
 - ✔ Spotrebič je odpojený od zdroja vody.
1. Odoberte spodný kryt.

2. Odpojte hadicu od držiaka.

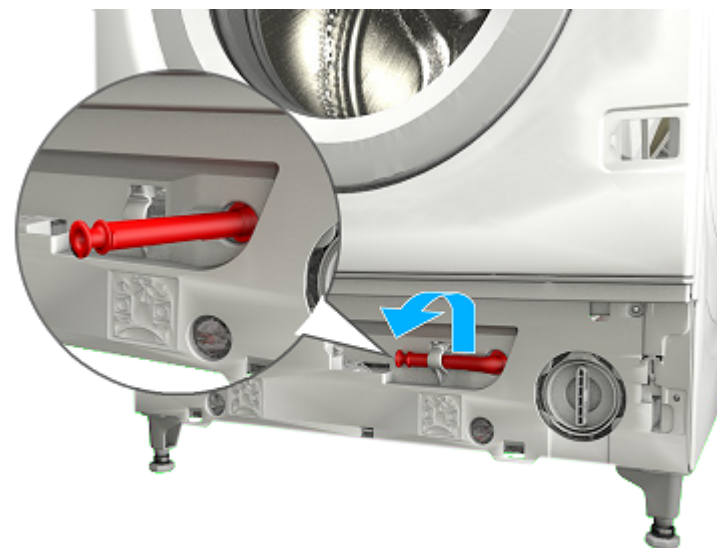

3. 1. Odskrutkujte skrutku (1).
2. Zatlačte na zachytávací bod a odoberte ho smerom nadol (2).

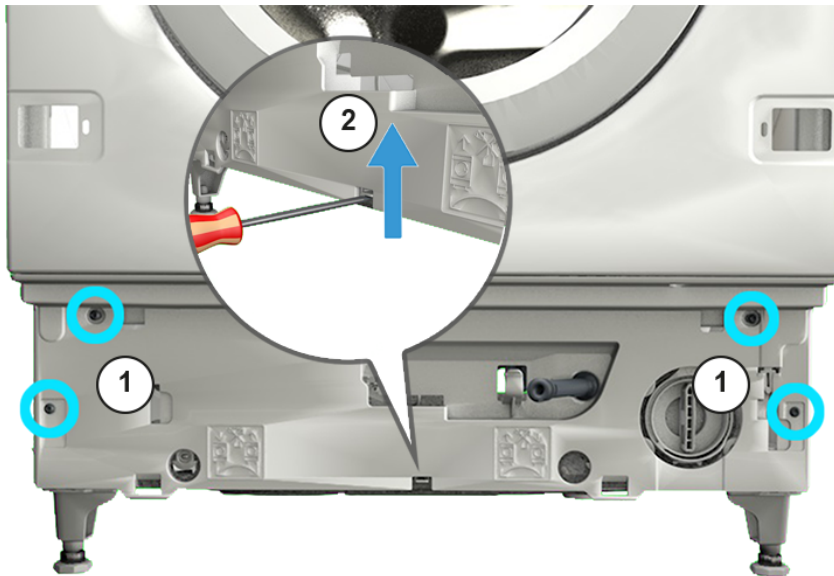

4. Zatiahnite spodný spoločný kryt a odoberte ho smerom dopredu.

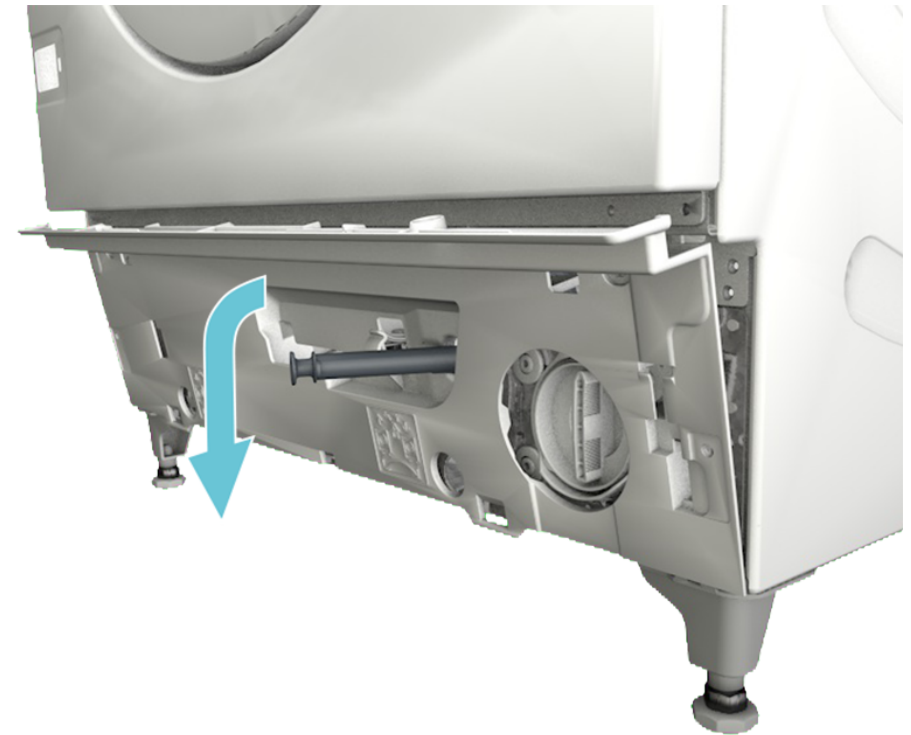

5. Vytiahnite hadicu z krytu.

4.10.2 Montáž krytu

- Pri montáži postupujte v opačnom poradí krokov demontáže.

4.11 Výmena čelného panela



UPOZORNENIE

Ostré hrany plášt'a!
Rezné poranenia
▶ Noste ochranné rukavice.

Požiadavka:

- ✔ Spotrebič je odpojený od elektrického napájania.
- ✔ Spotrebič je odpojený od zdroja vody.
- ✔ Spotrebič je voľne dostupný.
- ✔ [Zásuvka na prací prostriedok bola odobratá.→408](#)
- ✔ Čelo nábytku bolo odobraté.
- ✔ [Dvere boli odobraté.→410](#)
- ✔ Tesnenie dverí boli odobraté.

4.11.1 Odstránenie čelného panela

1. Uvoľnite držiak na svetidlo bubna.

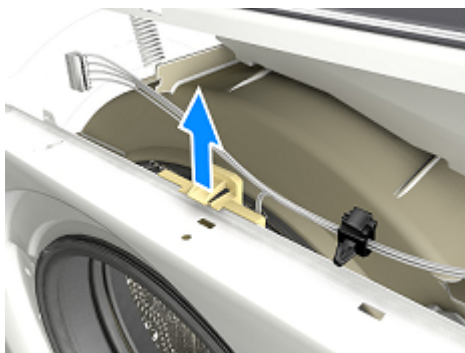

- 2.



UPOZORNENIE

Riziko pádu dielov po uvoľnení skrutiek!
Zranenie padajúcimi dielmi.
▶ Zaistite komponent proti pádu.



POZOR!

Riziko pádu dielov po uvoľnení skrutiek!
Poškodenie iných častí spotrebiča alebo domácnosti zákazníka, na pr. podlahy.
▶ Zaistite komponent proti pádu.

Uvoľnite skrutky v naznačenom poradí.



3. Odoberte čelný panel.

4.11.2 Montáž čelného panela

- ▶ Pri montáži postupujte v opačnom poradí krokov demontáže.

Nasveti za popravilo - Pralni stroj

| | |
|--|------------|
|  V zvezi s tem dokumentom | 423 |
| 1.1 Pomembne informacije | 423 |
| 1.1.1 Namen | 423 |
| 1.2 Razlaga simbolov | 423 |
| 1.2.1 Stopnje nevarnosti | 423 |
| 1.2.2 Simboli za nevarnost | 423 |
| 1.2.3 Struktura opozoril | 424 |
| 1.2.4 Splošni simboli | 424 |
|  Varnost..... | 425 |
| 2.1 Splošna varnostna navodila | 425 |
| 2.1.1 Vsi gospodinjski aparati | 425 |
|  Orodja in pripomočki..... | 426 |
|  Popravilo | 427 |
| 4.1 Zamenjava plošče za vence | 427 |
| 4.1.1 Odstranjevanje plošče za vence..... | 427 |
| 4.1.2 Namestitev plošče za vence | 428 |
| 4.2 Zamenjava predalčka za detergent | 429 |
| 4.2.1 Odstranjevanje predalčka za detergent | 429 |
| 4.2.2 Namestitev predalčka za detergent | 429 |
| 4.3 Zamenjava ročaja predalčka za detergent | 430 |
| 4.3.1 Odstranjevanje ročaja predalčka za detergent | 430 |
| 4.3.2 Namestitev ročaja predalčka za detergent | 430 |
| 4.4 Zamenjava vrat | 431 |
| 4.4.1 Odstranjevanje vrat | 431 |
| 4.4.2 Namestitev vrat..... | 431 |
| 4.5 Zamenjava komponent vrat | 432 |
| 4.5.1 Odstranjevanje komponent vrat | 432 |
| 4.5.2 Namestitev komponent vrat | 432 |
| 4.6 Zamenjava tečaja vrat..... | 433 |
| 4.6.1 Odstranjevanje tečaja vrat | 433 |
| 4.6.2 Namestitev tečaja vrat..... | 433 |
| 4.7 Zamenjava tesnila vrat..... | 434 |
| 4.7.1 Odstranjevanje tesnila vrat | 434 |
| 4.7.2 Namestitev tesnila vrat | 435 |

| | |
|--|-----|
| 4.8 Zamenjava varovala vrat | 436 |
| 4.8.1 Odstranjevanje varovala vrat..... | 436 |
| 4.8.2 Namestitev varovala vrat..... | 437 |
| 4.9 Zamenjava luči bobna | 438 |
| 4.9.1 Odstranjevanje luči bobna..... | 438 |
| 4.9.2 Namestitev luči bobna..... | 438 |
| 4.10 Zamenjava spodnjega pokrova | 439 |
| 4.10.1 Odstranjevanje spodnjega pokrova..... | 439 |
| 4.10.2 Namestitev pokrova | 440 |
| 4.11 Zamenjava sprednje plošče | 441 |
| 4.11.1 Odstranjevanje sprednje plošče..... | 441 |
| 4.11.2 Namestitev sprednje plošče | 442 |

i V zvezi s tem dokumentom

1.1 Pomembne informacije

1.1.1 Namen

Ti namigi za popravila uporabnika podpirajo pri lastnoročnem popravilu aparatov skladno z veljavno direktivo glede okoljsko primerne zasnove (od marca 2021).





Vsebujejo informacije o tem, kako zamenjati določene rezervne dele, vključno z opozorili in tveganji.

Če imate kakšna vprašanja, se obrnite na našo servisno službo. Za škodo bomo odgovorni le, če ste namige za popravila upoštevali pravilno.

1.2 Razlaga simbolov

1.2.1 Stopnje nevarnosti

Stopnje opozoril so sestavljene iz simbola in signalne besede. Signalna beseda označuje stopnjo nevarnosti.





| Stopnja opozorila | Pomen |
|--|---|
|  NEVARNOST | Neupoštevanje opozorilnega sporočila bo povzročilo smrt ali hude poškodbe. |
|  OPOZORILO | Neupoštevanje opozorilnega sporočila lahko povzroči smrt ali hude poškodbe. |
|  PREVIDNO | Neupoštevanje opozorilnega sporočila lahko povzroči manjše poškodbe. |
|  POZOR! | Neupoštevanje opozorilnega sporočila lahko povzroči škodo na lastnini. |

Preglednica 1: Stopnje nevarnosti



1.2.2 Simboli za nevarnost

Simboli za nevarnost so simbolni prikazi, ki podajajo informacije o vrsti nevarnosti.

V tem dokumentu so uporabljeni naslednji simboli za nevarnost:

| Simbol za nevarnost | Pomen |
|---|---------------------------------------|
|  | Splošno opozorilno sporočilo |
|  | Nevarnost zaradi električne napetosti |
|  | Nevarnost eksplozije |
|  | Nevarnost ureznin |
|  | Nevarnost zmečkanin |

i V zvezi s tem dokumentom

| Simbol za nevarnost | Pomen |
|--|---|
|  | Nevarnost zaradi vročih površin |
|  | Nevarnost zaradi močnega magnetnega polja |
|  | Nevarnost zaradi neionizirajočega sevanja |

Preglednica 2: Simboli za nevarnost

1.2.3 Struktura opozoril

Opozorila v tem dokumentu imajo standardiziran videz in standardizirano strukturo.



| | |
|--|---|
|  | <div style="background-color: red; color: white; padding: 2px; text-align: center;">⚠ NEVARNOST</div> <p>Vrsta in vir nevarnosti! Morebitne posledice ob neupoštevanju nevarnosti/opozorila.</p> <ul style="list-style-type: none"> ▶ Ukrepi in prepovedi za preprečevanje nevarnosti. |
|--|---|





V naslednjem primeru je prikazano opozorilo, ki opozarja pred električnim udarom zaradi delov pod napetostjo. Naveden je ukrep za preprečevanje nevarnosti.

| | |
|---|---|
|  | <div style="background-color: red; color: white; padding: 2px; text-align: center;">⚠ NEVARNOST</div> <p>Nevarnost električnega udara zaradi delov pod napetostjo! Smrt zaradi električnega udara</p> <ul style="list-style-type: none"> ▶ Izključite aparate iz električnega omrežja vsaj 60 sekund pred začetkom popravil. |
|---|---|

1.2.4 Splošni simboli

V tem dokumentu so uporabljeni naslednji splošni simboli:

| Splošni simbol | Pomen |
|--|--|
|  | Identifikacija posebnega nasveta (besedilo in/ali slika) |
|  | Identifikacija preprostega nasveta (samo besedilo) |
|  | Identifikacija povezave na video vadnico |

| Splošni simbol | Pomen |
|---|---|
|  | Identifikacija potrebnih orodij |
|  | Identifikacija potrebnih predpogojev |
|  | Identifikacija pogoja (če ..., potem ...) |
|  | Identifikacija rezultata |
| Začetek | Identifikacija tipke ali gumba |
| [00123456] | Identifikacija številke dela |
| Stanje | Identifikacija prikazanega besedila/okna (na zaslonu aparata) |

Preglednica 3: Splošni simboli

2.1 Splošna varnostna navodila

2.1.1 Vsi gospodinjski aparati

Nevarnost električnega udara zaradi delov pod napetostjo!

- Napake zaradi popravil električnih komponent lahko povzročijo električni udar!
- Aparat izključite iz električnega omrežja vsaj 60 sekund pred začetkom del.
- Po popravilu je treba izvesti preizkus varnosti v skladu z VDE 0701 ali predpisi, ki veljajo za posamezno državo.

Nevarnost poškodb zaradi ostrih robov!

- Uporabljajte zaščitne rokavice.

Nevarnost zmečkanin med popravili, vzdrževanjem, odpravljanjem težav ali servisom zaradi težkih in premikajočih se komponent

- Uporabljajte zaščitne čevlje.
- Težke komponente zavarujte pred padanjem.
- Delov telesa ne vstavljajte v premikajoče se komponente.







Tveganje za varnost/delovanje aparata!





- Uporabljajte le originalne nadomestne dele.

Tveganje poškodb elektrostatično občutljivih komponent (ESD)!

- Ne dotikajte se modulov, vključno s povezavami in potmi vodnika.

Orodja in pripomočki

| Oznaka | Podrobnosti | Slike |
|--|---|--|
| Pomožno orodje [15000155] | Orodje za rahljanje plastičnih delov |  |
| Izvijač Torx T20 z izvrtino [00340764] | 100 mm, za vijake z varnostnim zatičem |  |
| Momentni ključ [15000441] | Momentni ključ 20–100 Nm | |
| Ploščati zvijač [00340854] | Steblo 3,5 mm x 0,6 mm x 100 mm, zaščitna izolacija 1000 V AC |  |
| Ploščati zvijač [00340855] | Steblo 5,5 mm x 1,0 mm x 125 mm, zaščitna izolacija 1000 V AC |  |
| Igličaste klešče, zakrivljene [00341269] | Dolžina 200 mm |  |
| Klešče za bočno rezanje [00342182] | Dolžina: 200 mm |  |

| Oznaka | Podrobnosti | Slike |
|-------------------------------|----------------------------|---|
| Kombinirani ključ [00340811] | Velikost ključa 10°mm, M6 |  |
| Combination wrench [00340814] | Velikost ključa 13°mm, M8 |  |
| Kombinirani ključ [00340817] | Velikost ključa 17 mm, M10 |  |
| Kombinirani ključ [15000459] | Velikost ključa 16°mm, M10 |  |

4.1 Zamenjava plošče za vence

| | |
|--|--|
|  | ⚠️ PREVIDNO Ostri robovi ohišja! Ureznine ▶ Uporabljajte zaščitne rokavice. |
|--|--|

| | |
|--|---|
|  | ⚠️ OPOZORILO Zdrs nagnjenih aparatov! Zlomi kosti/zmečkanine ▶ Aparate zaščitite pred zdrsavanjem. |
|--|---|

| | |
|--|--|
|  | ⚠️ PREVIDNO Nevarnost padajočih delov zaradi zrahljanih vijakov! Poškodbe zaradi padajočih delov. ▶ Komponento zaščitite pred padcem. |
|--|--|

| | |
|--|--|
|  | ⚠️ POZOR! Nevarnost padajočih delov zaradi zrahljanih vijakov! Škoda na drugih delih aparata ali pri uporabniku doma, npr. na tleh. ▶ Komponento zaščitite pred padcem. |
|--|--|

Zahteva:

- ✔️ Aparat je odklopljen iz omrežne napetosti.
- ✔️ Aparat je odklopljen iz vira vode.
- ✔️ Aparat je prosto dostopen.
- ✔️ [Predalček za detergent je bil odstranjen.→429](#)

4.1.1 Odstranjevanje plošče za vence

1. Sprostite držalni element (1).
2. Odstranite pokrov (2).

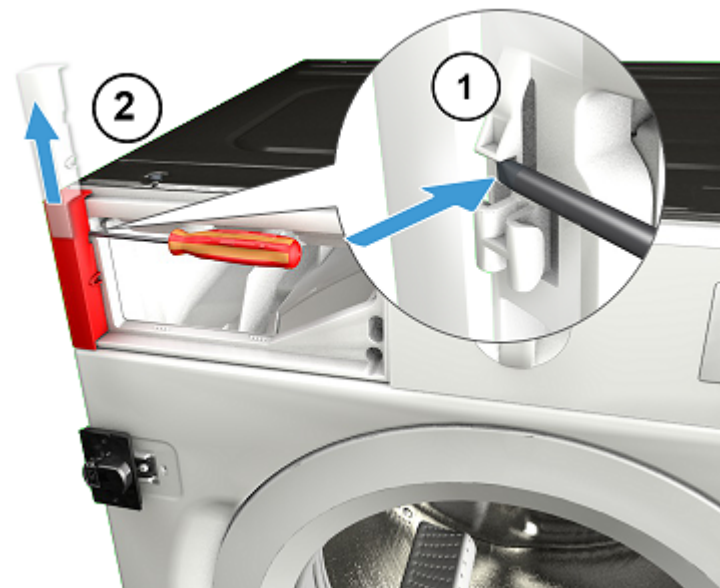

Popravilo

2. Odstranite vijake.



3. 1. Sprostite držalne elemente (1, 2).
2. Povlecite ploščo za vence proti sprednjemu delu (3).

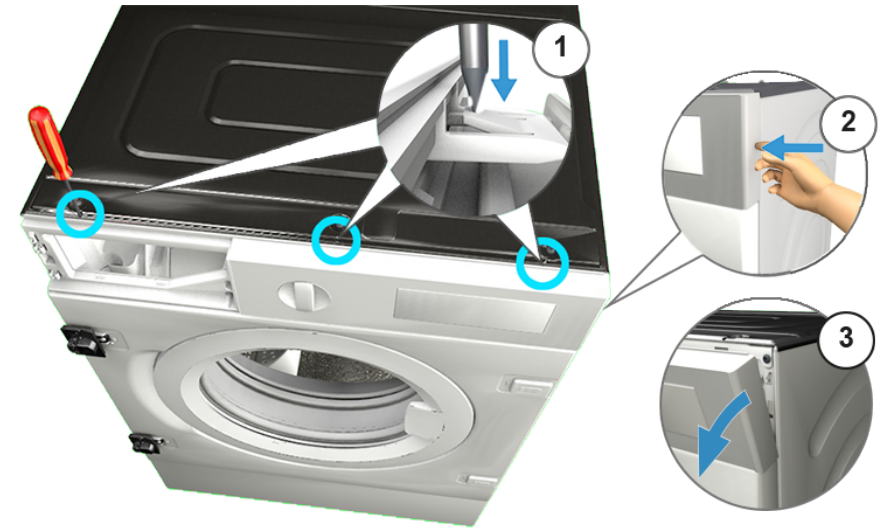

4. Odstranite ploščo za vence.

4.1.2 Namestitev plošče za vence

► Namestite v obratnem vrstnem redu.

4.2 Zamenjava predalčka za detergent

Zahteva:

- ✓ Aparat je odklopljen iz omrežne napetosti.
- ✓ Aparat je odklopljen iz vira vode.

4.2.1 Odstranjevanje predalčka za detergent

1. Izvlecite predalček za detergent.
2. 1. Vstavek (1) potisnite navzdol.
2. Odstranite predalček za detergent (2).

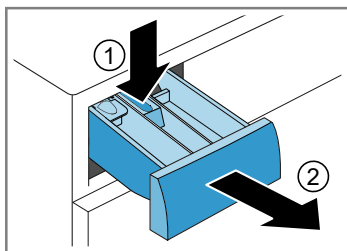

4.2.2 Namestitev predalčka za detergent

- ▶ Namestite v obratnem vrstnem redu.

4.3 Zamenjava ročaja predalčka za detergent

Zahteva:

- ✓ Aparat je odklopljen iz omrežne napetosti.
- ✓ Aparat je odklopljen iz vira vode.
- ✓ [Predalček za detergent je bil odstranjen.→429](#)

4.3.1 Odstranjevanje ročaja predalčka za detergent

1. Sprostite držalne elemente.

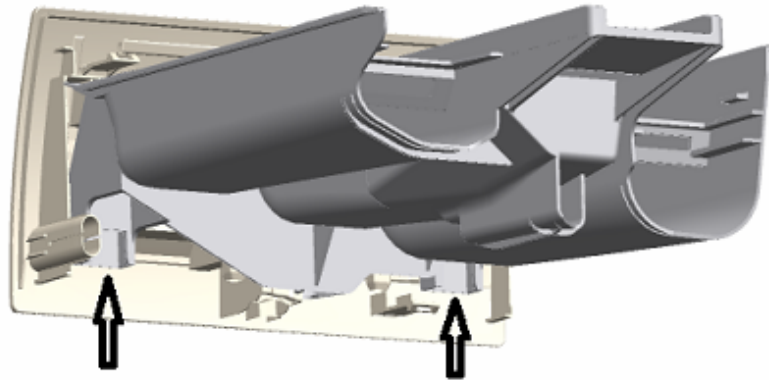

2. Odstranite ročaj predalčka za detergent.

4.3.2 Namestitev ročaja predalčka za detergent

- ▶ Namestite v obratnem vrstnem redu.

4.4 Zamenjava vrat



⚠️ PREVIDNO

Odprite območje tečaja!

Zmečkanine/zagozditev prstov

- ▶ Ne segajte v območje tečajev.
- ▶ Uporabljajte zaščitne rokavice.

Zahteva:

- ✔ Aparat je odklopljen iz omrežne napetosti.
- ✔ Aparat je odklopljen iz vira vode.
- ✔ Vrata so odprta.
- ✔ Pohištvna fronta je bila odstranjena.

4.4.1 Odstranjevanje vrat

1.



POZOR!

Nevarnost padajočih delov zaradi zrahljanih vijakov!

Škoda na drugih delih aparata ali pri uporabniku doma, npr. na tleh.
▶ Komponento zaščitite pred padcem.



⚠️ PREVIDNO

Nevarnost padajočih delov zaradi zrahljanih vijakov!

Poškodbe zaradi padajočih delov.

- ▶ Komponento zaščitite pred padcem.

Odstranite vijake (1).

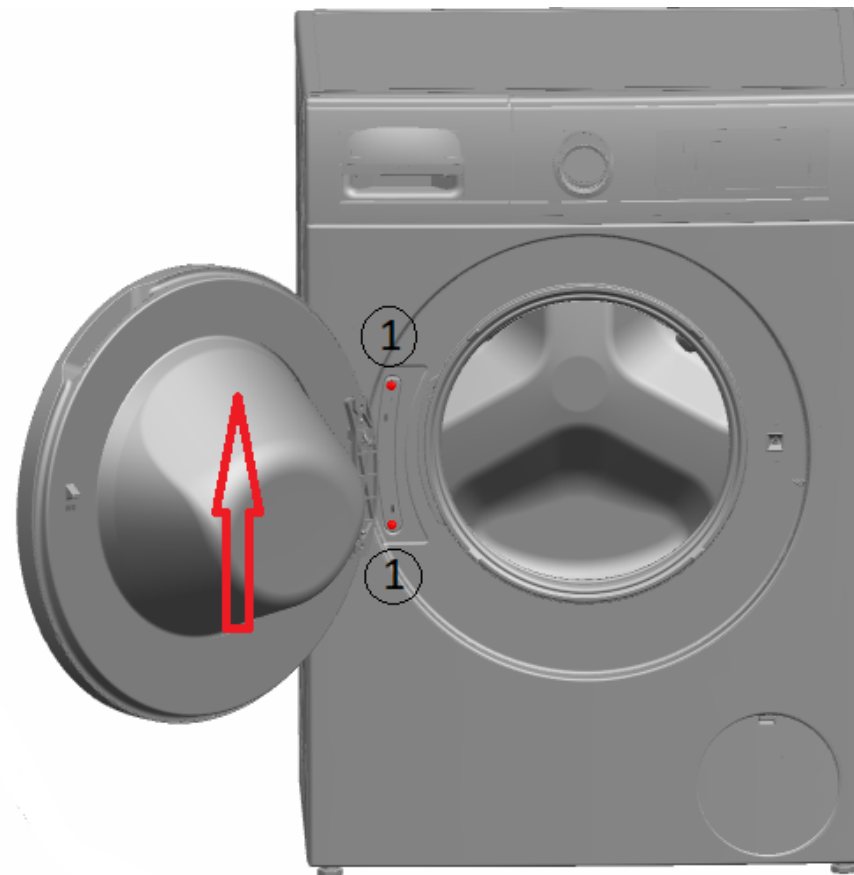

2. Odstranite vrata v smeri navzgor.

4.4.2 Namestitev vrat

- ▶ Namestite v obratnem vrstnem redu.

4.5 Zamenjava komponent vrat



⚠️ PREVIDNO

Odprite območje tečaja!

Zmečkanine/zagorzitev prstov

- ▶ Ne segajte v območje tečajev.
- ▶ Uporabljajte zaščitne rokavice.

Zahteva:

- ✔ Aparat je odklopljen iz omrežne napetosti.
- ✔ Aparat je odklopljen iz vira vode.
- ✔ Pohištvna fronta je bila odstranjena.
- ✔ [Vrata so bila odstranjena.→431](#)

4.5.1 Odstranjevanje komponent vrat

- ▶ Vrata razstavite od zunanje proti notranji strani.

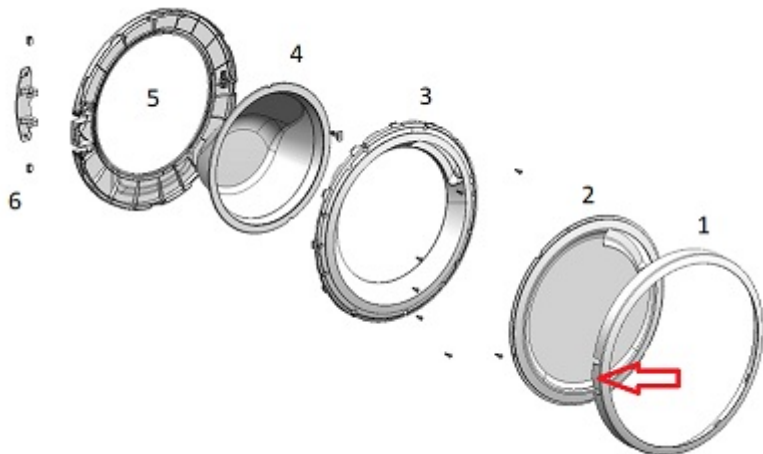

4.5.2 Namestitev komponent vrat

- ▶ Namestite v obratnem vrstnem redu.

4.6 Zamenjava tečaja vrat



PREVIDNO

Odprite območje tečaja!

Zmečkanine/zagozditev prstov

- ▶ Ne segajte v območje tečajev.
- ▶ Uporabljajte zaščitne rokavice.

Zahteva:

- ✓ Aparat je odklopljen iz omrežne napetosti.
- ✓ Aparat je odklopljen iz vira vode.

4.6.1 Odstranjevanje tečaja vrat

1. Sprostite dva vijaka.
2. Odstranite vrata.
3. Vrata razstavite od zunanje proti notranji strani.

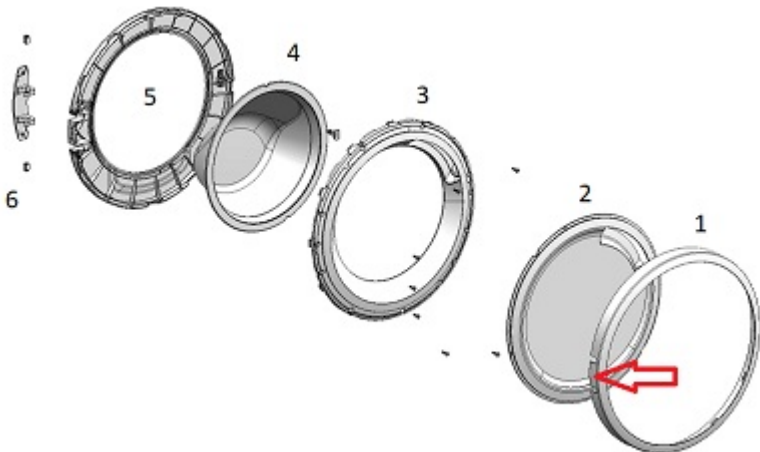



4. Odstranite tečaj vrat.

4.6.2 Namestitev tečaja vrat

- ▶ Namestite v obratnem vrstnem redu.

4.7 Zamenjava tesnila vrat

| | |
|--|--|
|  | ⚠️ PREVIDNO Ostri robovi ohišja! Ureznine ▶ Uporabljajte zaščitne rokavice. |
|--|--|

| | |
|--|--|
|  | ⚠️ PREVIDNO Nevarnost padajočih delov zaradi zrahljanih vijakov! Poškodbe zaradi padajočih delov. ▶ Komponento zaščitite pred padcem. |
|--|--|

| | |
|--|--|
|  | ⚠️ POZOR! Nevarnost padajočih delov zaradi zrahljanih vijakov! Škoda na drugih delih aparata ali pri uporabniku doma, npr. na tleh. ▶ Komponento zaščitite pred padcem. |
|--|--|

Zahteva:

- ✔️ Aparat je odklopljen iz omrežne napetosti.
- ✔️ Aparat je odklopljen iz vira vode.
- ✔️ Aparat je prosto dostopen.
- ✔️ [Predalček za detergent je bil odstranjen.→429](#)
- ✔️ Plošča za vence je bila odstranjena.
- ✔️ [Vrata so bila odstranjena.→431](#)
- ✔️ [Spodnji pokrov je bil odstranjen.→439](#)

4.7.1 Odstranjevanje tesnila vrat

1. Zrahljajte držalo na lučki bobna.



2.

| | |
|---|--|
|  | ⚠️ POZOR! Tveganje poškodb površine! Površina aparata se lahko ob uporabi napačnih orodij poškoduje. ▶ Za zamenjavo obroča napenjalnika uporabljajte le plastična orodja. |
|---|--|

S plastičnim orodjem odstranite obroč napenjalnika s tesnila.

3. Sprostite tesnilo vrat s sprednje plošče.
4. Sprostite priključek kabla z varovala vrat.

Popravilo

5. Zrahljajte vijake v navedenem vrstnem redu.



6. Odstranite sprednjo ploščo.

7. Odklopite vse priključke cevi.

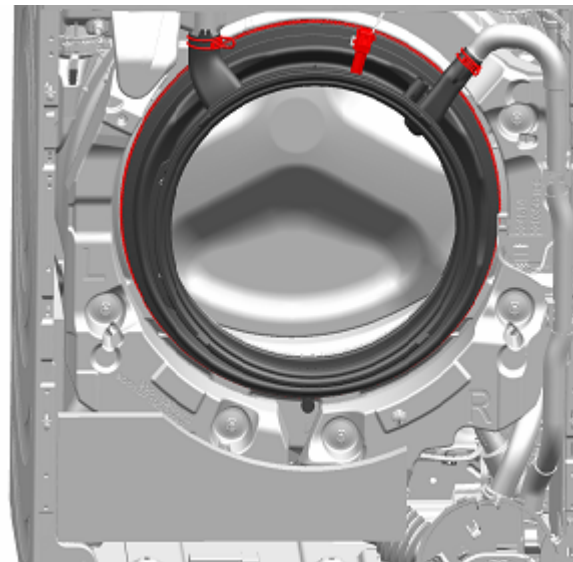

8. Odstranite tesnilo vrat.

4.7.2 Namestitev tesnila vrat

► Namestite v obratnem vrstnem redu.

4.8 Zamenjava varovala vrat

Kot proizvajalec moramo potrošnikom zagotoviti nadomestno varovalo vrat vklj. z navodili za uporabo v skladu z direktivo (EU) 2019/2023. Vendar želimo izpostaviti, da je po zamenjavi varovala vrat potreben preizkus elektrotehnične varnosti s strani kvalificiranega električarja, preden začnete z uporabo naprave. Ta oseba mora biti preverljivo kvalificirana v skladu z zakoni, predpisi in standardi, ki veljajo za posamezno državo.

| | |
|--|--|
|  | <p>NEVARNOST</p> <p>Nevarnost električnega udara zaradi delov pod napetostjo! Življenjska nevarnost zaradi električnega udara v primeru nepravilnega popravila</p> <ul style="list-style-type: none">▶ Električne dele mora popraviti kvalificiran električar.▶ Po popravilu je treba izvesti preizkus varnosti v skladu z VDE 0701 ali predpisi, ki veljajo za posamezno državo. |
|  | <p>PREVIDNO</p> <p>Ostri robovi ohišja! Ureznine</p> <ul style="list-style-type: none">▶ Uporabljajte zaščitne rokavice. |
|  | <p>OPOZORILO</p> <p>Zdrs nagnjenih aparatov! Zlomi kosti/zmečkanine</p> <ul style="list-style-type: none">▶ Aparate zaščitite pred zdrsavanjem. |
|  | <p>PREVIDNO</p> <p>Nevarnost padajočih delov zaradi zrahljanih vijakov! Poškodbe zaradi padajočih delov.</p> <ul style="list-style-type: none">▶ Komponento zaščitite pred padcem. |
|  | <p>POZOR!</p> <p>Nevarnost padajočih delov zaradi zrahljanih vijakov! Škoda na drugih delih aparata ali pri uporabniku doma, npr. na tleh.</p> <ul style="list-style-type: none">▶ Komponento zaščitite pred padcem. |

Zahteva:

- ✓ Aparat je odklopljen iz omrežne napetosti.
- ✓ Aparat je odklopljen iz vira vode.

- ✓ Aparat je prosto dostopen.
- ✓ Pohištvna fronta je bila odstranjena.
- ✓ Plošča za vence je bila odstranjena.
- ✓ [Vrata so bila odstranjena. → 431](#)
- ✓ Obroč napenjalnika je bil odstranjen.
- ✓ Sprednja plošča je bila odstranjena.
- ✓ Tesnilo vrat je bilo odstranjeno.

4.8.1 Odstranjevanje varovala vrat

1. Odklopite vtič varovala vrat.
2. Sprostite varovalo vrat.



3. Odstranite varovalo vrat.

4.8.2 Namestitev varovala vrat

Varovalo vrat mora biti v pravilnem položaju, da na aparatu zagotovite delovanje funkcije odpiranja vrat v sili.

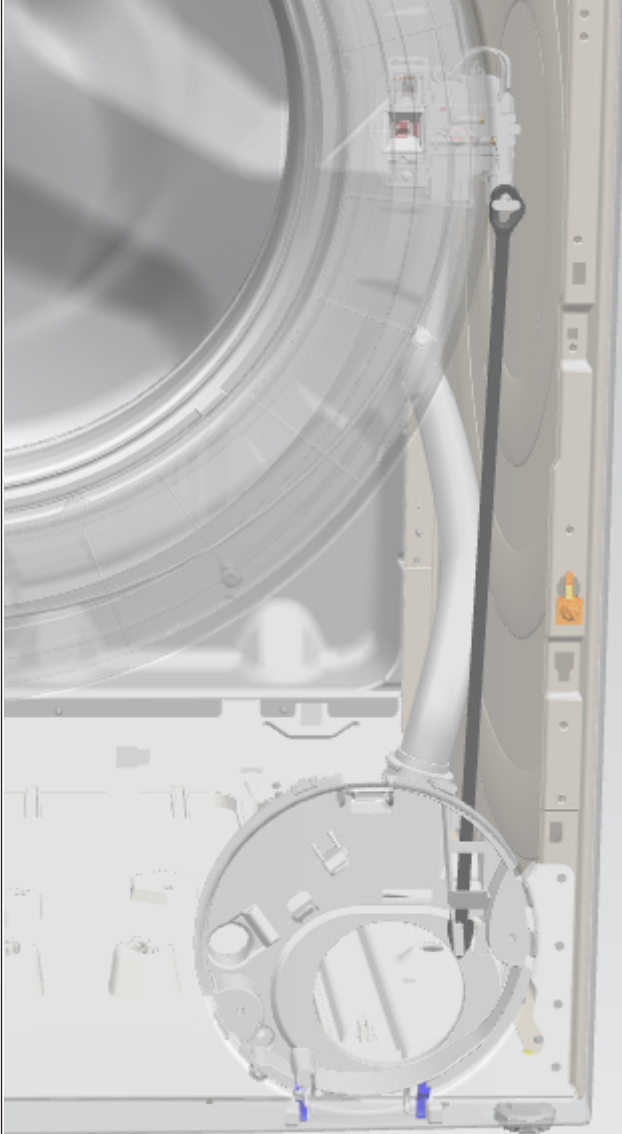

- ▶ Namestite v obratnem vrstnem redu.

4.9 Zamenjava luči bobna



⚠️ PREVIDNO

Ostri robovi ohišja!
Ureznine
▶ Uporabljajte zaščitne rokavice.



⚠️ OPOZORILO

Zdrs nagnjenih aparatov!
Zlomi kosti/zmečkanine
▶ Aparate zaščitite pred zdrsavanjem.



⚠️ PREVIDNO

Nevarnost padajočih delov zaradi zrahljanih vijakov!
Poškodbe zaradi padajočih delov.
▶ Komponento zaščitite pred padcem.



⚠️ POZOR!

Nevarnost padajočih delov zaradi zrahljanih vijakov!
Škoda na drugih delih aparata ali pri uporabniku doma, npr. na tleh.
▶ Komponento zaščitite pred padcem.

Zahteva:

- ✔ Aparat je odklopljen iz omrežne napetosti.
- ✔ Aparat je odklopljen iz vira vode.
- ✔ Aparat je prosto dostopen.
- ✔ [Predalček za detergent je bil odstranjen.→429](#)
- ✔ Plošča za vence je bila odstranjena.

4.9.1 Odstranjanje luči bobna

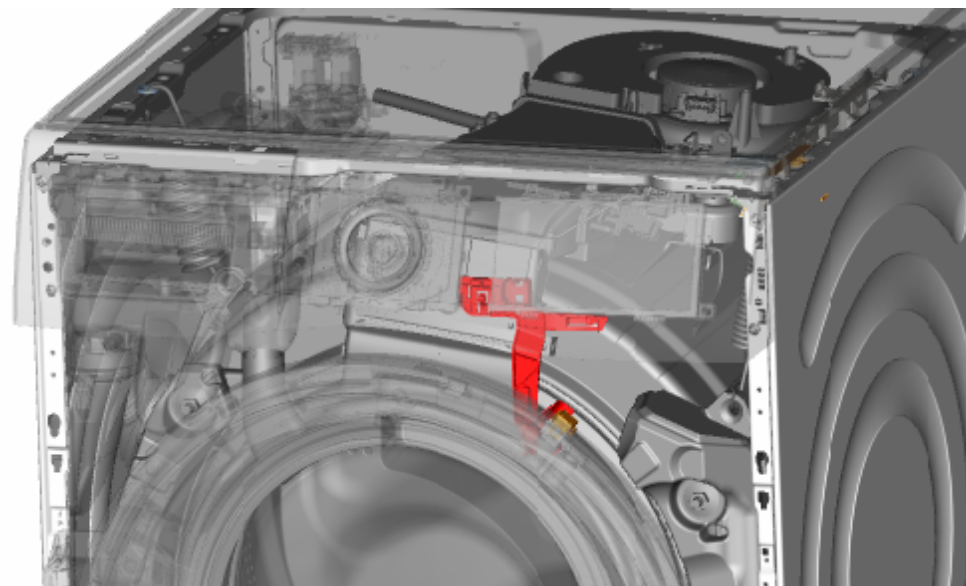

1. Izvlecite držalo luči bobna iz aparata.
2. Odklopite električne priključke.
3. Odstranite luč bobna z držala luči bobna.

4.9.2 Namestitev luči bobna



- ▶ Namestite v obratnem vrstnem redu.

4.10 Zamenjava spodnjega pokrova





Sl. 1: Pokrov spodnje skupine

Zahteva:

-  Aparat je odklopljen iz omrežne napetosti.
-  Aparat je odklopljen iz vira vode.
-  Pohištvena fronta je bila odstranjena.

4.10.1 Odstranjevanje spodnjega pokrova

Zahteva:

-  Aparat je odklopljen iz omrežne napetosti.
-  Aparat je odklopljen iz vira vode.

1. Odstranite spodnji pokrov.

2. Odklopite cev z držala.



Popravilo

3. 1. Odvijte vijak (1).
2. Pritisnite točko zadrževanja in odstranite v smeri navzdol (2).

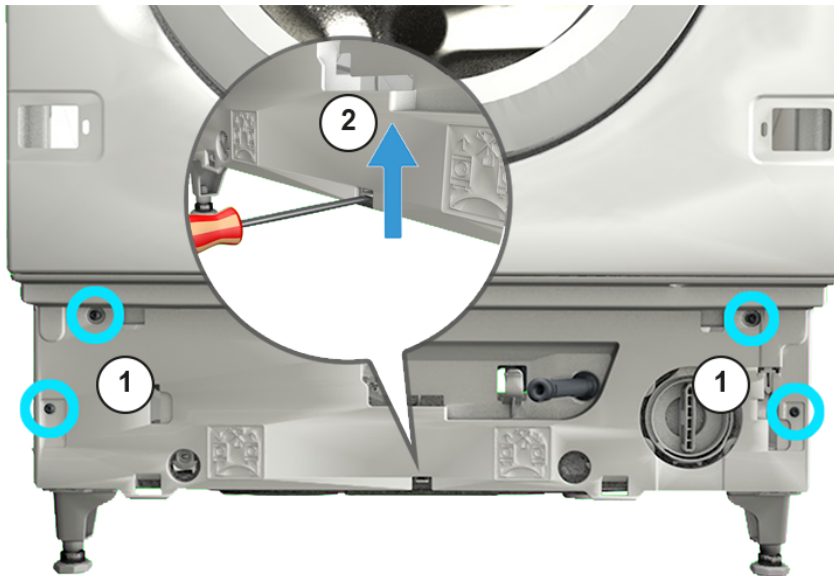

4. Povlecite pokrov spodnje skupine in ga odstranite v smeri naprej.

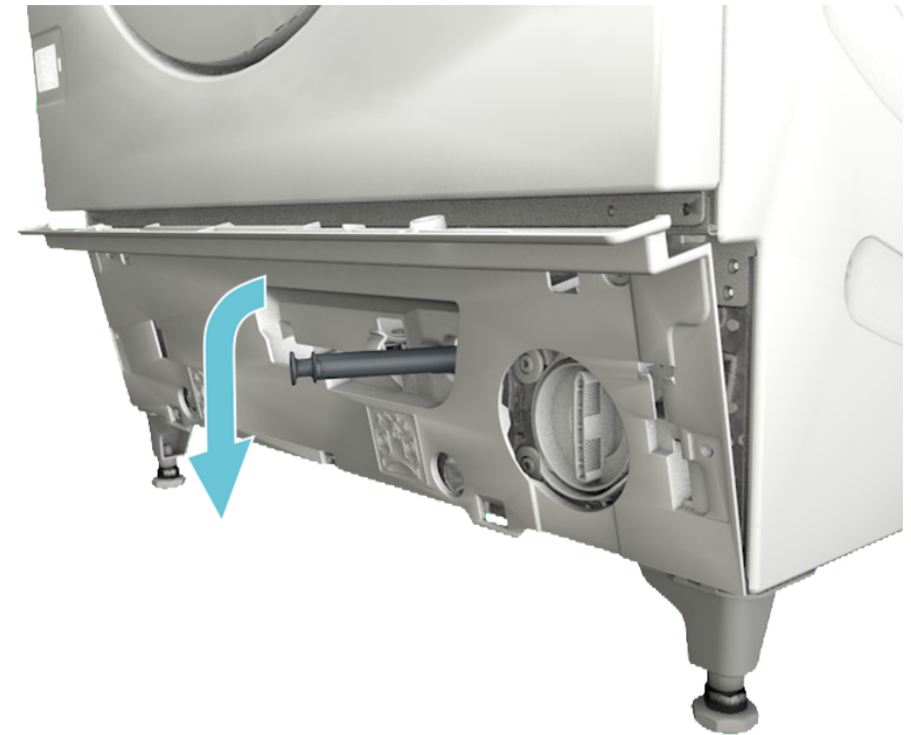

5. Izvlecite cev iz pokrova.

4.10.2 Namestitev pokrova

- Namestite v obratnem vrstnem redu.

4.11 Zamenjava sprednje plošče



PREVIDNO

Ostri robovi ohišja!

Ureznine

- ▶ Uporabljajte zaščitne rokavice.

Zahteva:

- ✓ Aparat je odklopljen iz omrežne napetosti.
- ✓ Aparat je odklopljen iz vira vode.
- ✓ Aparat je prosto dostopen.
- ✓ [Predalček za detergent je bil odstranjen. →429](#)
- ✓ Pohištvena fronta je bila odstranjena.
- ✓ [Vrata so bila odstranjena. →431](#)
- ✓ Tesnilo vrat je bilo odstranjeno.

4.11.1 Odstranjevanje sprednje plošče

1. Zrahljajte držalo na lučki bobna.

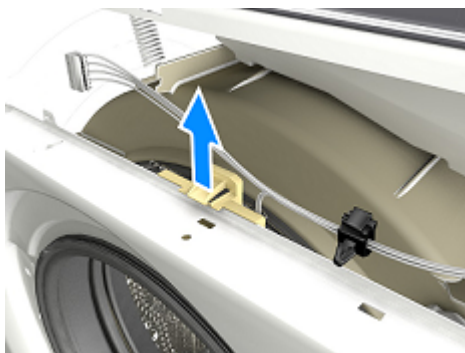

2.



PREVIDNO

Nevarnost padajočih delov zaradi zrahljanih vijakov!

Poškodbe zaradi padajočih delov.

- ▶ Komponento zaščitite pred padcem.



POZOR!

Nevarnost padajočih delov zaradi zrahljanih vijakov!

Škoda na drugih delih aparata ali pri uporabniku doma, npr. na tleh.

- ▶ Komponento zaščitite pred padcem.

Zrahljajte vijake v navedenem vrstnem redu.



Popravilo

3. Odstranite sprednjo ploščo.

4.11.2 Namestitev sprednje plošče

- ▶ Namestite v obratnem vrstnem redu.

Consejos de reparación - Lavadora

| | |
|--|------------|
|  En relación con este documento | 444 |
| 1.1 Información importante | 444 |
| 1.1.1 Finalidad | 444 |
| 1.2 Explicación de símbolos generales | 444 |
| 1.2.1 Niveles de peligrosidad | 444 |
| 1.2.2 Símbolos de peligro | 444 |
| 1.2.3 Estructura de las advertencias | 445 |
| 1.2.4 Símbolos generales | 445 |
|  Seguridad | 446 |
| 2.1 Instrucciones generales de seguridad | 446 |
| 2.1.1 Todos los aparatos electrodomésticos..... | 446 |
|  Herramientas y auxiliares | 447 |
|  Reparación | 448 |
| 4.1 Sustituir el panel de control | 448 |
| 4.1.1 Desmontar el panel de control | 448 |
| 4.1.2 Montar el panel de control | 449 |
| 4.2 Sustituir el compartimento para detergente | 450 |
| 4.2.1 Desmontar el compartimento para detergente | 450 |
| 4.2.2 Montar el compartimento para detergente | 450 |
| 4.3 Sustituir el tirador del compartimento para detergente | 451 |
| 4.3.1 Desmontar el tirador del compartimento para detergente..... | 451 |
| 4.3.2 Montar el tirador del compartimento para detergente..... | 451 |
| 4.4 Sustituir la puerta | 452 |
| 4.4.1 Extraer la puerta | 452 |
| 4.4.2 Montar la puerta..... | 452 |
| 4.5 Sustituir los componentes de la puerta..... | 453 |
| 4.5.1 Desmontar los componentes de la puerta..... | 453 |
| 4.5.2 Montar los componentes de la puerta..... | 453 |
| 4.6 Sustituir la bisagra de la puerta | 454 |
| 4.6.1 Desmontar la bisagra de la puerta..... | 454 |
| 4.6.2 Montar la bisagra de la puerta..... | 454 |
| 4.7 Sustituir la junta de la puerta | 455 |
| 4.7.1 Extraer la junta de la puerta | 455 |
| 4.7.2 Montar la junta de la puerta | 456 |

| | |
|---|-----|
| 4.8 Sustituir el cierre de la puerta | 457 |
| 4.8.1 Extraer el cierre de la puerta | 457 |
| 4.8.2 Montar el cierre de la puerta..... | 458 |
| 4.9 Sustituir la iluminación del tambor | 459 |
| 4.9.1 Desmontar la iluminación del tambor | 459 |
| 4.9.2 Montar la iluminación del tambor | 459 |
| 4.10 Sustituir la tapa inferior..... | 460 |
| 4.10.1 Retirar la tapa inferior | 460 |
| 4.10.2 Montar la tapa | 461 |
| 4.11 Sustituir el panel frontal..... | 462 |
| 4.11.1 Extraer el panel frontal..... | 462 |
| 4.11.2 Montar el panel frontal | 463 |

i En relación con este documento

1.1 Información importante

1.1.1 Finalidad

Estas indicaciones de reparación sirven como ayuda al consumidor para reparar aparatos por su cuenta conforme al reglamento aplicable sobre diseño ecológico (a partir de 03/2021).

Contienen información sobre cómo sustituir repuestos determinados e incluye las advertencias y los riesgos.

En caso de dudas, póngase en contacto con nuestro departamento de atención al cliente. Solo asumiremos la responsabilidad por daños si las indicaciones de reparación se han seguido correctamente.

1.2 Explicación de símbolos generales

1.2.1 Niveles de peligrosidad

Los niveles de peligro consisten en un símbolo y una palabra de advertencia. La palabra de advertencia identifica la gravedad del peligro.





| Nivel de peligro | Significado |
|--|---|
|  PELIGRO | Si no se tiene en cuenta la advertencia, ocasionará la muerte o lesiones graves. |
|  ADVERTENCIA | Si no se tiene en cuenta la advertencia, puede ocasionar la muerte o lesiones graves. |
|  PRECAUCIÓN | Si no se tiene en cuenta la advertencia, puede ocasionar lesiones de carácter leve. |
| ATENCIÓN | Si no se tiene en cuenta la advertencia, puede ocasionar daños materiales. |

Tabla 1: Niveles de peligrosidad

1.2.2 Símbolos de peligro

Los símbolos de peligro son una representación simbólica que indica el tipo de peligrosidad.

En este documento se utilizan los siguientes símbolos de peligro:

| Símbolo de peligro | Significado |
|---|---|
|  | Advertencia general |
|  | Peligro de lesiones por corriente eléctrica |
|  | Riesgo de explosión |
|  | Peligro de lesiones a causa de cortes |

i En relación con este documento





| Símbolo de peligro | Significado |
|--|---|
|  | Peligro de lesiones por aplastamiento |
|  | Peligro de lesiones por superficies calientes |
|  | Peligro a causa de campos magnéticos de gran potencia |
|  | Peligro derivado de radiación no ionizante |

Tabla 2: Símbolos de peligro

1.2.3 Estructura de las advertencias

Las advertencias de este documento tienen una apariencia y una estructura uniformes.

| | |
|--|---|
|  | <div style="background-color: red; color: white; padding: 2px; text-align: center;">⚠ PELIGRO</div> <p>¡Tipo y fuente del peligro! Posibles consecuencias de ignorar el peligro / la advertencia.</p> <ul style="list-style-type: none"> ▶ Medidas y prohibiciones para prevenir el peligro. |
|--|---|

El ejemplo siguiente muestra una advertencia de descarga eléctrica a causa de piezas o partes cargadas con tensión. Se menciona la medida para evitar el peligro.

| | |
|--|---|
|  | <div style="background-color: red; color: white; padding: 2px; text-align: center;">⚠ PELIGRO</div> <p>¡Riesgo de descarga eléctrica debido a partes con tensión! Muerte por electrocución</p> <ul style="list-style-type: none"> ▶ Desconectar el aparato de la red al menos 60 segundos antes de comenzar con la reparación. |
|--|---|

1.2.4 Símbolos generales

En este documento se utilizan los siguientes símbolos generales:

| Símbolo general | Significado |
|--|---|
|  | Identificación de una indicación especial (texto y/o gráfico) |







| Símbolo general | Significado |
|---|---|
|  | Identificación de un consejo simple (solo texto) |
|  | Identificación de un enlace a un video tutorial |
|  | Identificación de una herramienta requerida |
|  | Identificación de una condición previa (prerrequisito) |
|  | Identificación de una condición (si ..., entonces ...) |
|  | Identificación de un resultado |
| Iniciar | Identificación de una tecla o botón |
| [00123456] | Identificación de un número de material |
| Estado | Identificación del texto / ventana mostrado (en el display del aparato) |

Tabla 3: Símbolos generales

2.1 Instrucciones generales de seguridad

2.1.1 Todos los aparatos electrodomésticos

¡Riesgo de descarga eléctrica debido a piezas con tensión!

- ¡Los errores en las reparaciones que incluyan componentes eléctricos pueden provocar una descarga eléctrica!
- Desconectar el aparato de la red durante al menos 60 segundos antes de comenzar con el trabajo.
- Después de la reparación, encargar una prueba de seguridad conforme a VDE 0701 o los reglamentos específicos del país.

¡Riesgo de lesiones debido a bordes afilados!

- Usar guantes de protección.

Riesgo de aplastamiento durante la reparación, mantenimiento, resolución de problemas y servicio debido a componentes pesados y móviles

- Usar calzado de seguridad.
- Asegure los componentes pesados para que no se caigan.
- No pegue partes del cuerpo en componentes móviles.





¡Riesgo para la seguridad/el funcionamiento del aparato!





- Utilizar únicamente los repuestos originales.

¡Riesgo de daños de los componentes sensibles a cargas electrostáticas (ESD)!





- No tocar los módulos, incluidas las conexiones y las pistas conductoras.

Herramientas y auxiliares

| Designación | Detalles | Imágenes |
|---|--|--|
| Herramienta auxiliar [15000155] | Herramienta para aflojar piezas de plástico |  |
| Destornillador Torx T20 con orificio de centrado [00340764] | 100 mm, para tornillos de seguridad |  |
| Llave dinamométrica [15000441] | Llave dinamométrica 20 - 100 Nm | |
| Destornillador plano [00340854] | Punta 3,5 mm x 0,6 mm x 100 mm, Protección aislamiento 1000 V AC |  |
| Destornillador plano [00340855] | Punta 5,5 mm x 1,0 mm x 125 mm, Protección aislamiento 1000 V AC |  |
| Alicates de punta fina curvada [00341269] | Longitud 200 mm |  |

| Designación | Detalles | Imágenes |
|------------------------------------|-------------------------|---|
| Alicates corte diagonal [00342182] | Longitud: 200 mm |  |
| Llave combinada [00340811] | Medida llave 10°mm, M6 |  |
| Combination wrench [00340814] | Medida llave 13°mm, M8 |  |
| Llave combinada [00340817] | Medida llave 17 mm, M10 |  |
| Llave combinada [15000459] | Medida llave 16°mm, M10 |  |

4.1 Sustituir el panel de control

| | |
|--|--|
|  | <p>⚠ PRECAUCIÓN</p> <p>¡Bordes de la carcasa cortantes! Peligro de cortes</p> <ul style="list-style-type: none">▶ Usar guantes de seguridad. |
|  | <p>⚠ ADVERTENCIA</p> <p>¡Deslizamiento de aparatos inclinados! Fracturas óseas / lesiones por aplastamiento</p> <ul style="list-style-type: none">▶ Asegurar los electrodomésticos contra deslizamientos. |
|  | <p>⚠ PRECAUCIÓN</p> <p>¡Riesgo de que se caigan piezas debido a los tornillos aflojados! Peligro de lesiones debido a piezas que caigan.</p> <ul style="list-style-type: none">▶ Asegure el componente para que no se caiga. |
|  | <p>⚠ ATENCION</p> <p>¡Riesgo de que se caigan piezas debido a los tornillos aflojados! Daños en otras partes del aparato o en el domicilio del consumidor, p. ej., en la parte inferior.</p> <ul style="list-style-type: none">▶ Asegure el componente para que no se caiga. |

Requisito:

- ✓ El aparato está desconectado del suministro eléctrico.
- ✓ El aparato está desconectado del suministro de agua.
- ✓ Puede accederse libremente al aparato.
- ✓ [Se ha retirado el compartimento para detergente. → 450](#)

4.1.1 Desmontar el panel de control

1. Soltar el elemento de sujeción (1).
2. Extraer la tapa (2).

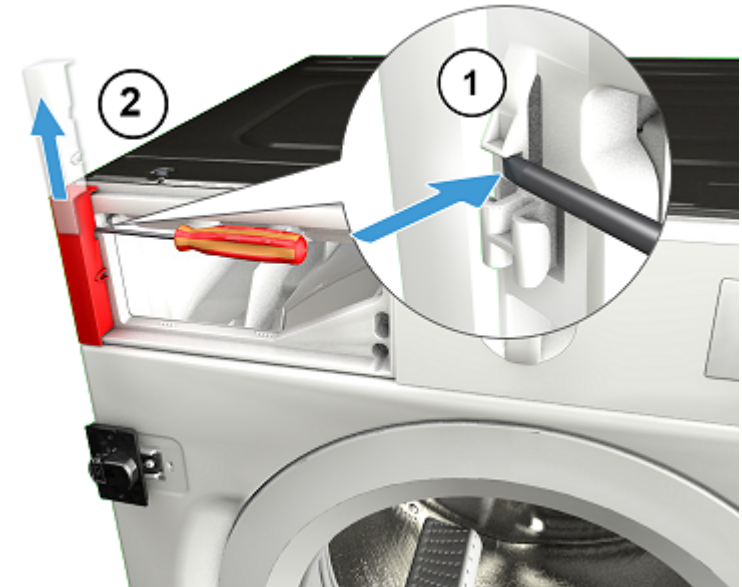

Reparación

2. Retirar los tornillos.



3. 1. Desenganchar los elementos de sujeción (1, 2).
2. Empujar el panel de control hacia la parte frontal (3).

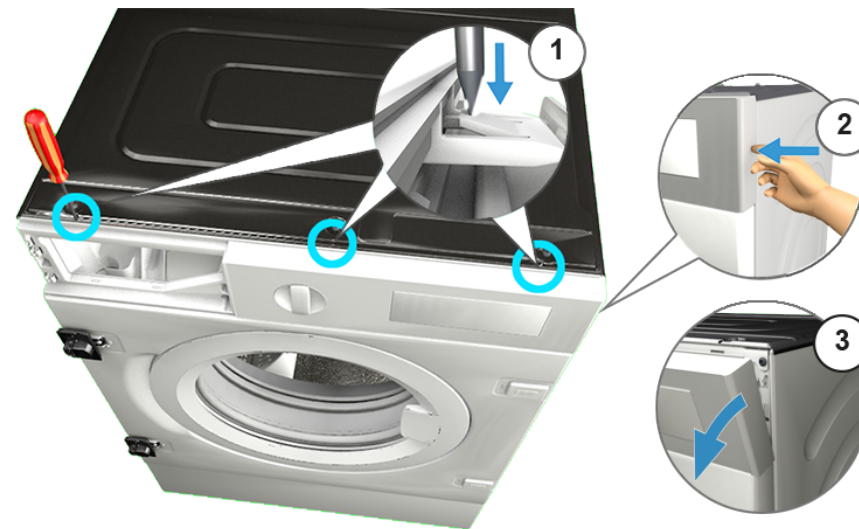

4. Desmontar el panel de control.

4.1.2 Montar el panel de control

► Montar en orden inverso.

4.2 Sustituir el compartimento para detergente

Requisito:

- ✓ El aparato está desconectado del suministro eléctrico.
- ✓ El aparato está desconectado del suministro de agua.

4.2.1 Desmontar el compartimento para detergente

1. Extraer el compartimento para detergente.
2.
 1. Presione hacia abajo en el inserto (1).
 2. Desmontar el compartimento para detergente (2).

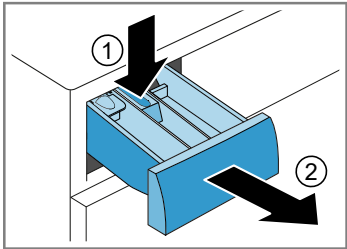

4.2.2 Montar el compartimento para detergente

- ▶ Montar en orden inverso.

4.3 Sustituir el tirador del compartimento para detergente

Requisito:

- ✓ El aparato está desconectado del suministro eléctrico.
- ✓ El aparato está desconectado del suministro de agua.
- ✓ [Se ha retirado el compartimento para detergente. →450](#)

4.3.1 Desmontar el tirador del compartimento para detergente

1. Desenganchar los elementos de sujeción.

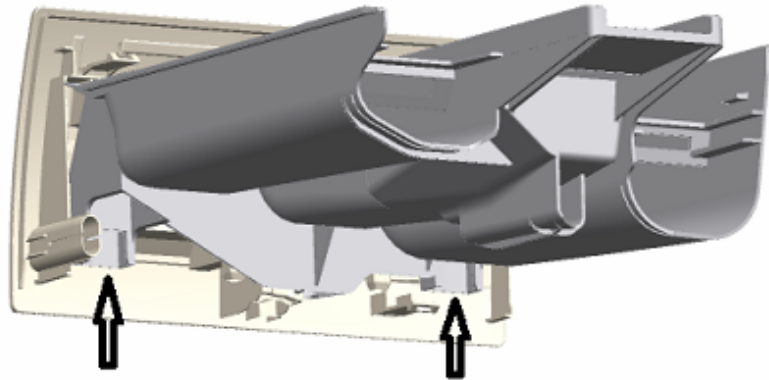

2. Desmontar el tirador del compartimento para detergente.

4.3.2 Montar el tirador del compartimento para detergente

- ▶ Montar en orden inverso.

4.4 Sustituir la puerta



⚠️ PRECAUCIÓN

¡Zona de bisagra abierta!

- Aplastamiento / atrapamiento de dedos
- ▶ No acceder a la zona de la bisagra.
 - ▶ Usar guantes de seguridad.

Requisito:

- ✔ El aparato está desconectado del suministro eléctrico.
- ✔ El aparato está desconectado del suministro de agua.
- ✔ La puerta está abierta.
- ✔ Se ha quitado el frontal del mueble.

4.4.1 Extraer la puerta

1.



⚠️ ATENCION

¡Riesgo de que se caigan piezas debido a los tornillos aflojados!

- Daños en otras partes del aparato o en el domicilio del consumidor, p. ej., en la parte inferior.
- ▶ Asegure el componente para que no se caiga.



⚠️ PRECAUCIÓN

¡Riesgo de que se caigan piezas debido a los tornillos aflojados!

- Peligro de lesiones debido a piezas que caigan.
- ▶ Asegure el componente para que no se caiga.

Retirar los tornillos (1).

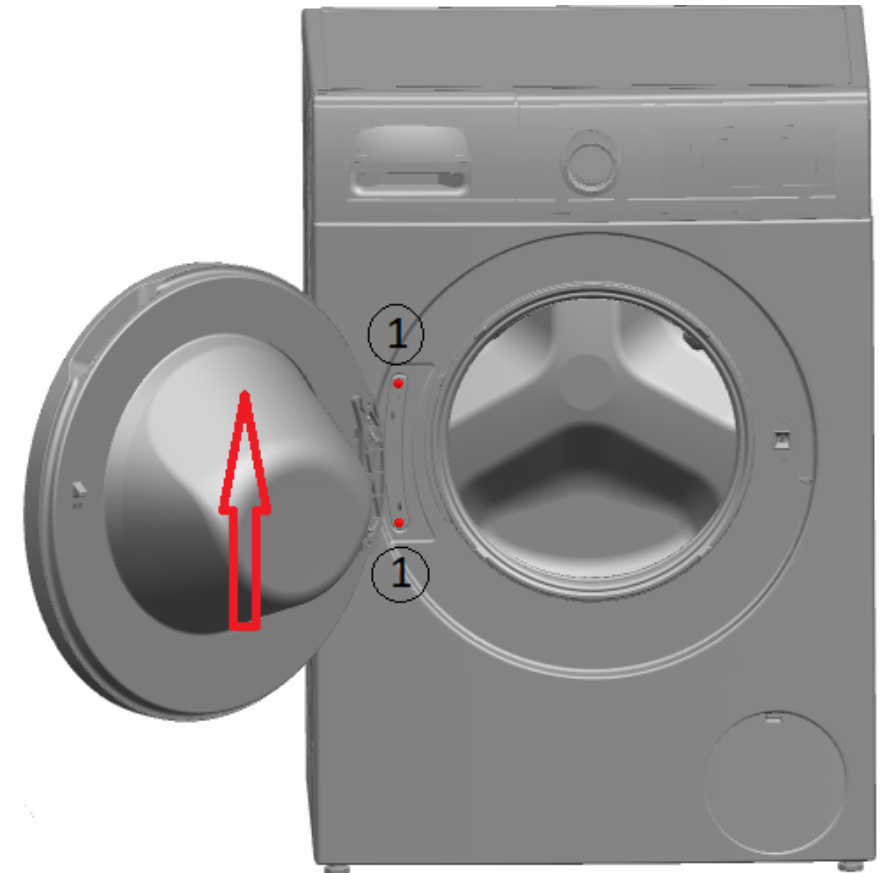

2. Extraer la puerta hacia arriba.

4.4.2 Montar la puerta

- ▶ Montar en orden inverso.

4.5 Sustituir los componentes de la puerta

| | |
|--|---|
|  | <p>⚠ PRECAUCIÓN</p> <p>¡Zona de bisagra abierta! Aplastamiento / atrapamiento de dedos</p> <ul style="list-style-type: none">▶ No acceder a la zona de la bisagra.▶ Usar guantes de seguridad. |
|--|---|

Requisito:

- ✓ El aparato está desconectado del suministro eléctrico.
- ✓ El aparato está desconectado del suministro de agua.
- ✓ Se ha quitado el frontal del mueble.
- ✓ [Se ha retirado la puerta.→452](#)

4.5.1 Desmontar los componentes de la puerta

- ▶ Desmontar la puerta desde fuera hacia dentro.

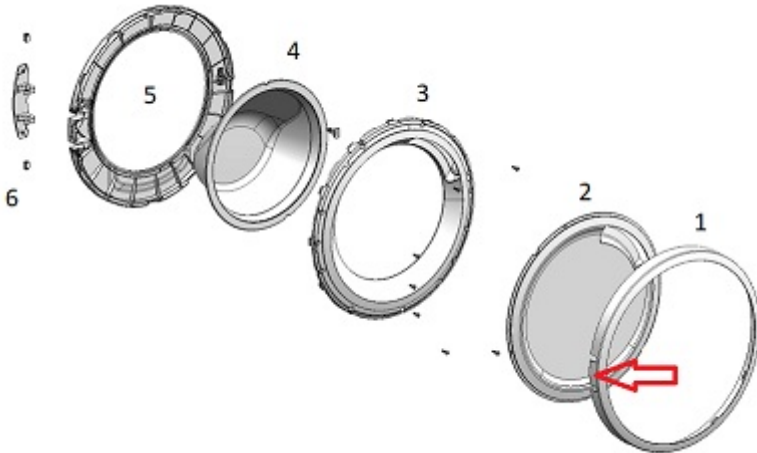

4.5.2 Montar los componentes de la puerta

- ▶ Montar en orden inverso.

4.6 Sustituir la bisagra de la puerta



PRECAUCIÓN

¡Zona de bisagra abierta!

Aplastamiento / atrapamiento de dedos

- ▶ No acceder a la zona de la bisagra.
- ▶ Usar guantes de seguridad.

Requisito:

- ✓ El aparato está desconectado del suministro eléctrico.
- ✓ El aparato está desconectado del suministro de agua.

4.6.1 Desmontar la bisagra de la puerta

1. Aflojar los dos tornillos.
2. Retirar la puerta.
3. Desmontar la puerta desde fuera hacia dentro.

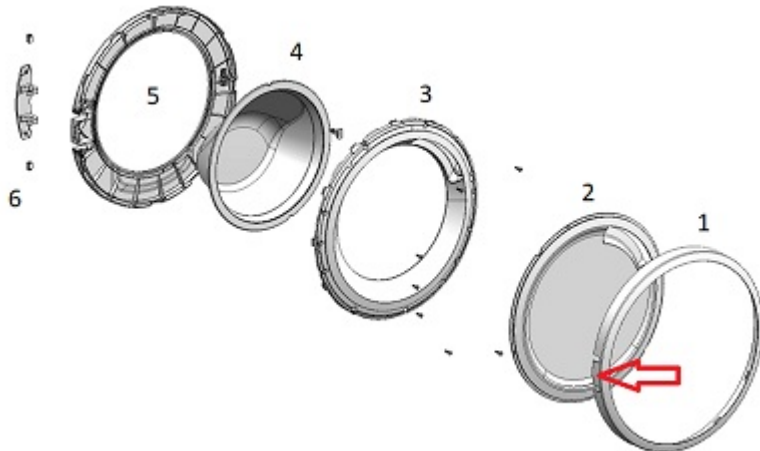



4. Retirar la bisagra de la puerta.

4.6.2 Montar la bisagra de la puerta

- ▶ Montar en orden inverso.

4.7 Sustituir la junta de la puerta

| | |
|--|---|
|  | PRECAUCIÓN ¡Bordes de la carcasa cortantes! Peligro de cortes ▶ Usar guantes de seguridad. |
|--|---|

| | |
|--|---|
|  | PRECAUCIÓN ¡Riesgo de que se caigan piezas debido a los tornillos aflojados! Peligro de lesiones debido a piezas que caigan. ▶ Asegure el componente para que no se caiga. |
|--|---|

| | |
|--|---|
|  | ATENCION ¡Riesgo de que se caigan piezas debido a los tornillos aflojados! Daños en otras partes del aparato o en el domicilio del consumidor, p. ej., en la parte inferior. ▶ Asegure el componente para que no se caiga. |
|--|---|

Requisito:

- ✓ El aparato está desconectado del suministro eléctrico.
- ✓ El aparato está desconectado del suministro de agua.
- ✓ Puede accederse libremente al aparato.
- ✓ [Se ha retirado el compartimento para detergente.→450](#)
- ✓ Se ha retirado el panel de control.
- ✓ [Se ha retirado la puerta.→452](#)
- ✓ [Se ha retirado la tapa inferior.→460](#)

4.7.1 Extraer la junta de la puerta

1. Aflojar el enganche en la iluminación del tambor.

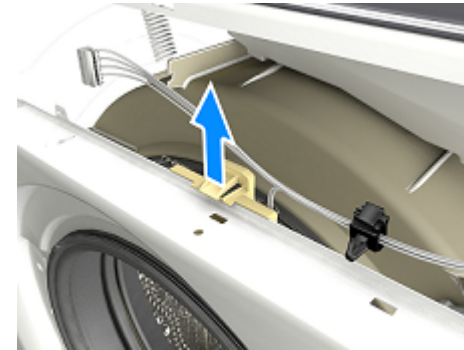

2.

| | |
|---|--|
|  | ATENCION ¡Riesgo de daños en la superficie! La superficie del aparato puede sufrir arañazos si se utilizan las herramientas incorrectas. ▶ Utilizar únicamente herramientas de plástico para sustituir el anillo de fijación. |
|---|--|

Desmontar el anillo de fijación de la junta con una herramienta de plástico.

3. Quitar la junta de la puerta del panel frontal.
4. Abrir el conector de cable del cierre de la puerta.

Reparación

5. Aflojar los tornillos en el orden indicado.



6. Retirar el panel frontal.

7. Desconectar todas las conexiones de manguera.

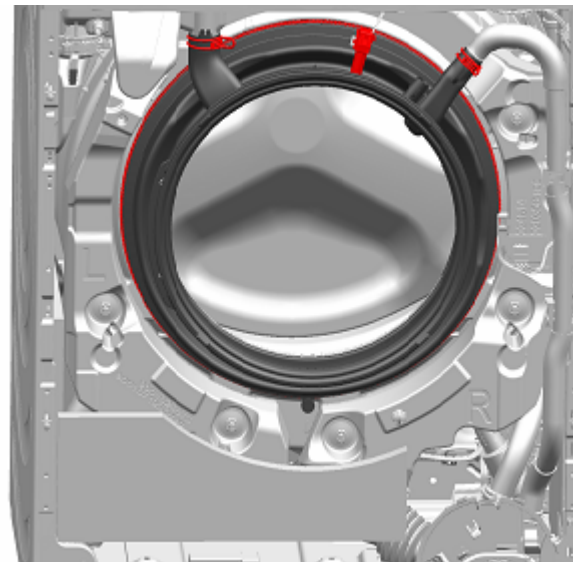

8. Retirar la junta de la puerta.

4.7.2 Montar la junta de la puerta

► Montar en orden inverso.

4.8 Sustituir el cierre de la puerta

Como fabricante, estamos obligados a proporcionar a los clientes la pieza de repuesto de la cerradura de puerta, incluidas las instrucciones de reparación conforme al Reglamento (UE) 2019/2023. No obstante, nos gustaría resaltar que después de reemplazar la cerradura de la puerta, es necesario que un electricista cualificado realice una prueba de seguridad electrotécnica antes de poner el aparato en funcionamiento. Esta persona debe estar cualificada (de forma verificable) de acuerdo con las leyes, reglamentos y normas específicos del país.

| | |
|--|---|
|  | ⚠ PELIGRO |
| | <p>¡Riesgo de descarga eléctrica debido a piezas con tensión! Peligro mortal por descarga eléctrica en caso de reparación inadecuada</p> <ul style="list-style-type: none"> ▶ Las piezas eléctricas deberían ser reparadas por electricistas cualificados. ▶ Después de la reparación, encargar una prueba de seguridad conforme a VDE 0701 o los reglamentos específicos del país. |

| | |
|--|--|
|  | ⚠ PRECAUCIÓN |
| | <p>¡Bordes de la carcasa cortantes! Peligro de cortes</p> <ul style="list-style-type: none"> ▶ Usar guantes de seguridad. |

| | |
|---|--|
|  | ⚠ ADVERTENCIA |
| | <p>¡Deslizamiento de aparatos inclinados! Fracturas óseas / lesiones por aplastamiento</p> <ul style="list-style-type: none"> ▶ Asegurar los electrodomésticos contra deslizamientos. |

| | |
|--|--|
|  | ⚠ PRECAUCIÓN |
| | <p>¡Riesgo de que se caigan piezas debido a los tornillos aflojados! Peligro de lesiones debido a piezas que caigan.</p> <ul style="list-style-type: none"> ▶ Asegure el componente para que no se caiga. |

| | |
|--|--|
|  | ⚠ ATENCION |
| | <p>¡Riesgo de que se caigan piezas debido a los tornillos aflojados! Daños en otras partes del aparato o en el domicilio del consumidor, p. ej., en la parte inferior.</p> <ul style="list-style-type: none"> ▶ Asegure el componente para que no se caiga. |

Requisito:

- ✓ El aparato está desconectado del suministro eléctrico.
- ✓ El aparato está desconectado del suministro de agua.
- ✓ Puede accederse libremente al aparato.
- ✓ Se ha quitado el frontal del mueble.
- ✓ Se ha retirado el panel de control.
- ✓ [Se ha retirado la puerta.→452](#)
- ✓ Se ha retirado el anillo de fijación.
- ✓ Se ha retirado el panel frontal.
- ✓ Se ha retirado la junta de la puerta.

4.8.1 Extraer el cierre de la puerta

1. Desconectar el enchufe del cierre de la puerta.
2. Abrir el cierre de la puerta.



3. Retirar el cierre de la puerta.

4.8.2 Montar el cierre de la puerta

El cierre de la puerta debe estar en la posición correcta para garantizar la función del aparato para apertura de emergencia de la puerta.





- ▶ Montar en orden inverso.

4.9 Sustituir la iluminación del tambor

| | |
|--|---|
|  | ⚠ PRECAUCIÓN ¡Bordes de la carcasa cortantes! Peligro de cortes ▶ Usar guantes de seguridad. |
|--|---|

| | |
|--|--|
|  | ⚠ ADVERTENCIA ¡Deslizamiento de aparatos inclinados! Fracturas óseas / lesiones por aplastamiento ▶ Asegurar los electrodomésticos contra deslizamientos. |
|--|--|

| | |
|--|---|
|  | ⚠ PRECAUCIÓN ¡Riesgo de que se caigan piezas debido a los tornillos aflojados! Peligro de lesiones debido a piezas que caigan. ▶ Asegure el componente para que no se caiga. |
|--|---|

| | |
|--|--|
|  | ⚠ ATENCION ¡Riesgo de que se caigan piezas debido a los tornillos aflojados! Daños en otras partes del aparato o en el domicilio del consumidor, p. ej., en la parte inferior. ▶ Asegure el componente para que no se caiga. |
|--|--|

Requisito:

- ✔ El aparato está desconectado del suministro eléctrico.
- ✔ El aparato está desconectado del suministro de agua.
- ✔ Puede accederse libremente al aparato.
- ✔ [Se ha retirado el compartimento para detergente. → 450](#)
- ✔ Se ha retirado el panel de control.

4.9.1 Desmontar la iluminación del tambor

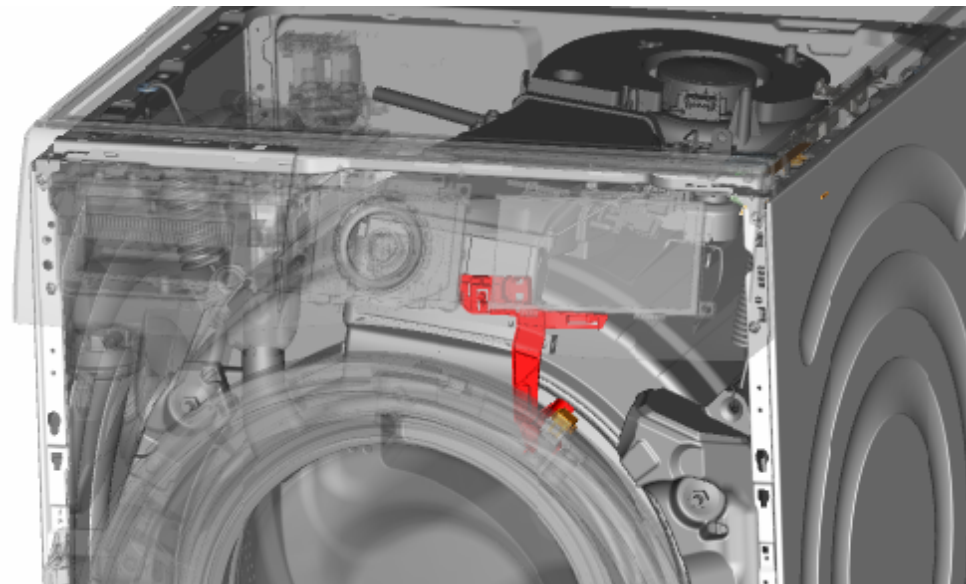

1. Sacar del aparato el soporte de la iluminación del tambor.
2. Desconectar las conexiones eléctricas.
3. Desmontar la iluminación del tambor del soporte.

4.9.2 Montar la iluminación del tambor

- ▶ Montar en orden inverso.

4.10 Sustituir la tapa inferior



Fig. 1: Tapa del grupo inferior

Requisito:

- ✓ El aparato está desconectado del suministro eléctrico.
- ✓ El aparato está desconectado del suministro de agua.
- ✓ Se ha quitado el frontal del mueble.

4.10.1 Retirar la tapa inferior

Requisito:

- ✓ El aparato está desconectado del suministro eléctrico.
- ✓ El aparato está desconectado del suministro de agua.

1. Retirar la tapa inferior.

2. Desconectar la manguera del soporte.



Reparación

3. 1. Aflojar el tornillo (1).
2. Presionar el punto de sujeción y extraerlo hacia abajo (2).

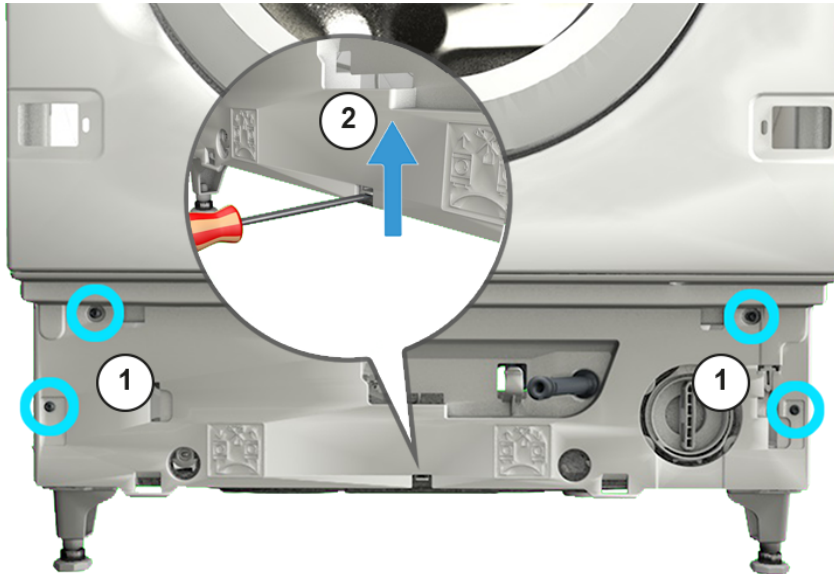

4. Tirar de la tapa del grupo inferior y extraerla hacia delante.

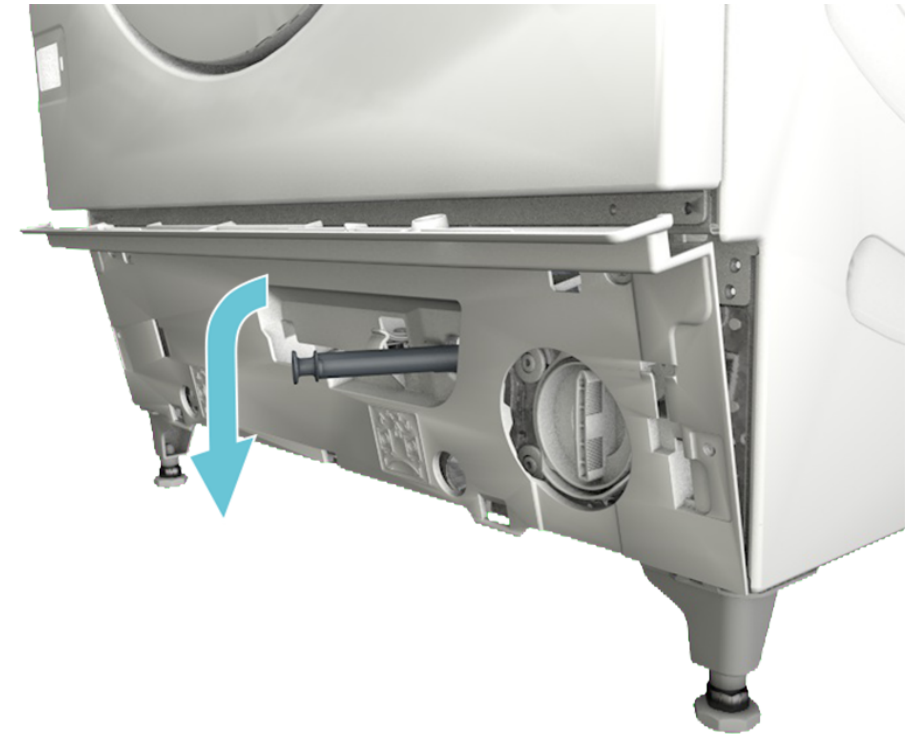

5. Sacar la manguera de la tapa.

4.10.2 Montar la tapa

- Montar en orden inverso.

4.11 Sustituir el panel frontal

| | |
|--|---|
|  | ⚠ PRECAUCIÓN ¡Bordes de la carcasa cortantes! Peligro de cortes ▶ Usar guantes de seguridad. |
|--|---|

Requisito:

- ✓ El aparato está desconectado del suministro eléctrico.
- ✓ El aparato está desconectado del suministro de agua.
- ✓ Puede accederse libremente al aparato.
- ✓ [Se ha retirado el compartimento para detergente. →450](#)
- ✓ Se ha quitado el frontal del mueble.
- ✓ [Se ha retirado la puerta. →452](#)
- ✓ Se ha retirado la junta de la puerta.

4.11.1 Extraer el panel frontal

1. Aflojar el enganche en la iluminación del tambor.

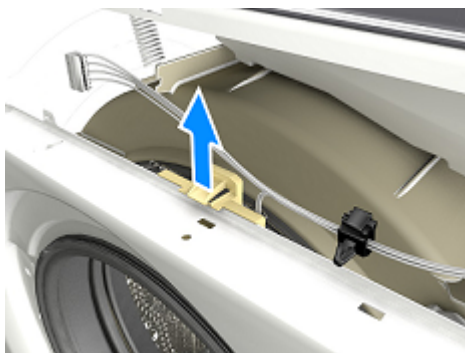

2.

| | |
|---|---|
|  | ⚠ PRECAUCIÓN ¡Riesgo de que se caigan piezas debido a los tornillos aflojados! Peligro de lesiones debido a piezas que caigan. ▶ Asegure el componente para que no se caiga. |
|---|---|

| | |
|---|---|
|  | ATENCIÓN ¡Riesgo de que se caigan piezas debido a los tornillos aflojados! Daños en otras partes del aparato o en el domicilio del consumidor, p. ej., en la parte inferior. ▶ Asegure el componente para que no se caiga. |
|---|---|

Aflojar los tornillos en el orden indicado.





3. Retirar el panel frontal.

4.11.2 Montar el panel frontal

- ▶ Montar en orden inverso.

Reparationsinformation - Tvättmaskin

| | |
|--|------------|
|  Om detta dokument | 465 |
| 1.1 Viktig information..... | 465 |
| 1.1.1 Syfte..... | 465 |
| 1.2 Symbolförklaringar..... | 465 |
| 1.2.1 Faronivåer..... | 465 |
| 1.2.2 Risksymboler..... | 465 |
| 1.2.3 Varningarnas struktur..... | 466 |
| 1.2.4 Allmänna symboler..... | 466 |
|  Säkerhet | 467 |
| 2.1 Allmänna säkerhetsanvisningar..... | 467 |
| 2.1.1 Alla hushållsmaskiner..... | 467 |
|  Verktyg och hjälpmedel | 468 |
|  Reparation | 469 |
| 4.1 Byta kontrollpanel..... | 469 |
| 4.1.1 Ta bort kontrollpanel..... | 469 |
| 4.1.2 Montera kontrollpanel..... | 470 |
| 4.2 Byta tvättmedelsfack..... | 471 |
| 4.2.1 Ta bort tvättmedelsfack..... | 471 |
| 4.2.2 Montera tvättmedelsfack..... | 471 |
| 4.3 Byta handtag till tvättmedelsfack..... | 472 |
| 4.3.1 Ta bort handtag till tvättmedelsfack..... | 472 |
| 4.3.2 Montera handtag till tvättmedelsfack..... | 472 |
| 4.4 Byta lucka..... | 473 |
| 4.4.1 Ta bort lucka..... | 473 |
| 4.4.2 Montera lucka..... | 473 |
| 4.5 Byta luckans komponenter..... | 474 |
| 4.5.1 Ta bort luckans komponenter..... | 474 |
| 4.5.2 Montera luckans komponenter..... | 474 |
| 4.6 Byta luckans gångjärn..... | 475 |
| 4.6.1 Ta bort luckans gångjärn..... | 475 |
| 4.6.2 Montera luckans gångjärn..... | 475 |
| 4.7 Byta luckans tätning..... | 476 |
| 4.7.1 Ta bort luckans tätning..... | 476 |
| 4.7.2 Montera luckans tätning..... | 477 |

| | |
|-----------------------------------|-----|
| 4.8 Byta luckans lås..... | 478 |
| 4.8.1 Ta bort luckans lås..... | 478 |
| 4.8.2 Montera luckans lås..... | 479 |
| 4.9 Byta trummans lampa..... | 480 |
| 4.9.1 Ta bort trummans lampa..... | 480 |
| 4.9.2 Montera luckans lampa..... | 480 |
| 4.10 Byta bottenhölje..... | 481 |
| 4.10.1 Ta bort bottenhölje..... | 481 |
| 4.10.2 Montera höljet..... | 482 |
| 4.11 Byta frontpanel..... | 483 |
| 4.11.1 Ta bort frontpanel..... | 483 |
| 4.11.2 Montera frontpanel..... | 484 |

i Om detta dokument

1.1 Viktig information

1.1.1 Syfte

Dessa reparationstips hjälper kunden att själv reparera maskiner enligt gällande ekodesignbestämmelser (som gäller 03/2021).





De innehåller information om hur vissa reservdelar ska bytas samt tillhörande varningar och risker.

Kontakta vår kundtjänst om du har frågor. Vi åtar oss bara ansvar för skador om reparationstipsen har följts korrekt.

1.2 Symbolförklaringar

1.2.1 Faronivåer

Varningsnivåerna består av en symbol och ett signalord. Signalordet visar hur allvarlig faran är.





| Varningsnivå | Innebörd |
|---|--|
|  | Om inte varningsmeddelandet följs kommer det att leda till dödsfall eller allvarliga personskador. |
|  | Om inte varningsmeddelandet följs kan det leda till dödsfall eller allvarliga personskador. |
|  | Om inte varningsmeddelandet följs kan det leda till lättare personskador. |
|  | Om inte varningsmeddelandet följs kan det leda till materialskador. |

Grafik 1: Faronivåer



1.2.2 Risksymboler

Risksymboler är symboler som visar typen av fara.

Följande risksymboler används i detta dokument:

| Risksymbol | Innebörd |
|---|-------------------------------------|
|  | Allmänt varningsmeddelande |
|  | Fara på grund av elektrisk spänning |
|  | Explosionsrisk |
|  | Fara för skärskador |
|  | Fara för krosskador |

i Om detta dokument

| Risksymbol | Innebörd |
|--|---|
|  | Fara på grund av heta ytor |
|  | Fara på grund av starka magnetfält |
|  | Fara på grund av icke-joniserande strålning |

Grafik 2: Risksymboler

1.2.3 Varningarnas struktur

Varningar i detta dokument har ett standardiserat utseende och en standardiserad struktur.



| | |
|--|--|
|  | <p> FARA!</p> <p>Farans typ och ursprung! Möjliga konsekvenser av att faran/varningen ignoreras.</p> <ul style="list-style-type: none"> ▶ Åtgärder och förbud för att förebygga faran. |
|--|--|





Följande exempel visar en varning som varnar för elstötar från strömförande delar. Det står vilken åtgärd som förebygger faran.

| | |
|---|---|
|  | <p> FARA!</p> <p>Risk för elstötar på grund av strömförande delar! Dödsfall på grund av elstötar</p> <ul style="list-style-type: none"> ▶ Koppla bort maskiner från elförsörjningen minst 60 sekunder innan reparationer påbörjas. |
|---|---|

1.2.4 Allmänna symboler

Följande allmänna symboler används i detta dokument:

| Allm. symbol | Innebörd |
|--|--|
|  | Identifiering av ett särskilt tips (text och/eller bild) |
|  | Identifiering av ett enkelt tips (endast text) |

| Allm. symbol | Innebörd |
|---|---|
|  | Identifiering av en länk till en videohandledning |
|  | Identifiering av verktyg som behövs |
|  | Identifiering av villkor som måste vara uppfyllda |
|  | Identifiering av ett tillstånd (om ..., så ...) |
|  | Identifiering av ett resultat |
| [Start] | Identifiering av en tangent eller knapp |
| [00123456] | Identifiering av ett materialnummer |
| Status | Identifiering av text/fönster som visas (i maskinens display) |

Grafik 3: Allmänna symboler

2.1 Allmänna säkerhetsanvisningar

2.1.1 Alla hushållsmaskiner

Risk för elstötar på grund av strömförande delar!

- Fel vid reparationer som berör elkomponenter kan orsaka elstötar!
- Koppla bort maskinen från elnätet minst 60 sekunder innan arbetet påbörjas.
- Låt utföra ett säkerhetstest efter reparationen, i enlighet med VDE 0701 eller landsspecifika regler.

Risk för personskador på grund av vassa kanter!

- Använd skyddshandskar.

Risk för krosskador vid reparation, underhåll, felsökning och service på grund av tunga och rörliga komponenter

- Använd skyddsskor.
- Säkra tunga komponenter så att de inte faller ner.
- Stick inte in kroppsdelar i rörliga komponenter.







Risk för maskinens säkerhet/funktion!



- Använd endast originaldelar.

Risk för skador på komponenter känsliga för statisk elektricitet (ESD)!

- Rör inte modulerna samt anslutningar och strömförande ledningar.

Verktyg och hjälpmedel

| Beteckning | Detaljer | Bilder |
|---|--|--|
| Hjälpverktyg [15000155] | Verktyg för att lossa plastdelar |  |
| Skruvmejsel torx T20 med borrhål [00340764] | 100 mm, för skruvar med säkerhetsstift |  |
| Momentnyckel [15000441] | Momentnyckel 20 - 100 Nm | |
| Spårskruvmejsel [00340854] | Blad 3,5 mm x 0,6 mm x 100 mm, skyddsisolering 1000 V AC |  |
| Spårskruvmejsel [00340855] | Blad 5,5 mm x 1,0 mm x 125 mm, skyddsisolering 1000 V AC |  |
| Spetstång, böjd [00341269] | Längd 200 mm |  |
| Sidavbitare [00342182] | Längd: 200 mm |  |

| Beteckning | Detaljer | Bilder |
|---------------------------------------|--|---|
| Kombinationsnyckel [00340811] | Skiftnyckelstorlek 10 ^o mm, M6 |  |
| Combination w- rench [00340814] | Skiftnyckelstorlek 13 ^o mm, M8 |  |
| Kombinationsnyckel [00340817] | Skiftnyckelstorlek 17 mm, M10 |  |
| Kombinationsnyckel [15000459] | Skiftnyckelstorlek 16 ^o mm, M10 |  |

4.1 Byta kontrollpanel



⚠️ FÖRSIKTIGT!

Vassa höljeskanter!
Skärskador
▶ Använd skyddshandskar.



⚠️ VARNING!

Lutande maskiner kan glida!
Frakturer/krosskador
▶ Säkra maskiner så att de inte kan glida.



⚠️ FÖRSIKTIGT!

Risk för fallande delar på grund av lossade skruvar!
Personskador på grund av fallande delar.
▶ Säkra komponenter så att de inte faller ner.



OBS!

Risk för fallande delar på grund av lossade skruvar!
Materiella skador på andra delar av maskinen eller i kundens hem, t.ex. vid botten.
▶ Säkra komponenter så att de inte faller ner.

Förutsättning:

- ✓ Apparaten är bortkopplad från strömförsörjning.
- ✓ Apparaten är bortkopplad från vattenförsörjning.
- ✓ Maskinen är fritt åtkomlig.
- ✓ [Tvättmedelsfacket har tagits bort. →471](#)

4.1.1 Ta bort kontrollpanel

1. Lossa fästelementet (1).
2. Ta bort höljet (2).

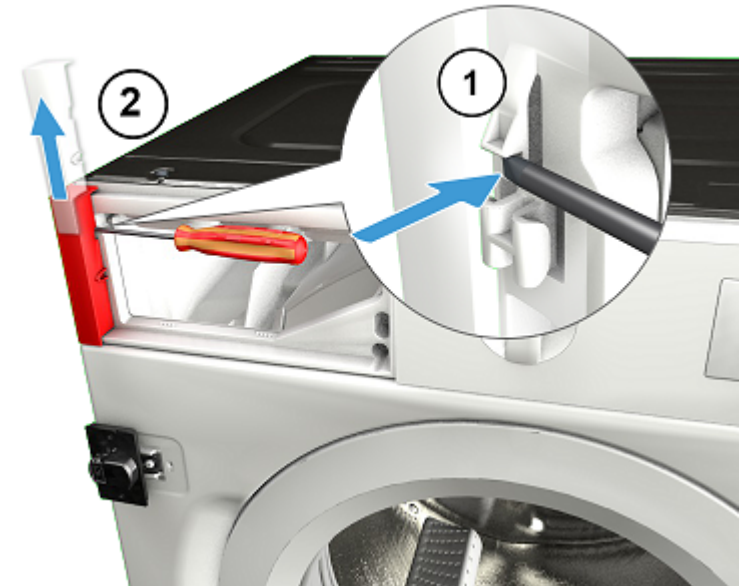

Reparation

2. Ta bort skruvarna.



3. 1. Lossa fästelementen (1, 2).
2. Dra kontrollpanelen mot fronten (3).

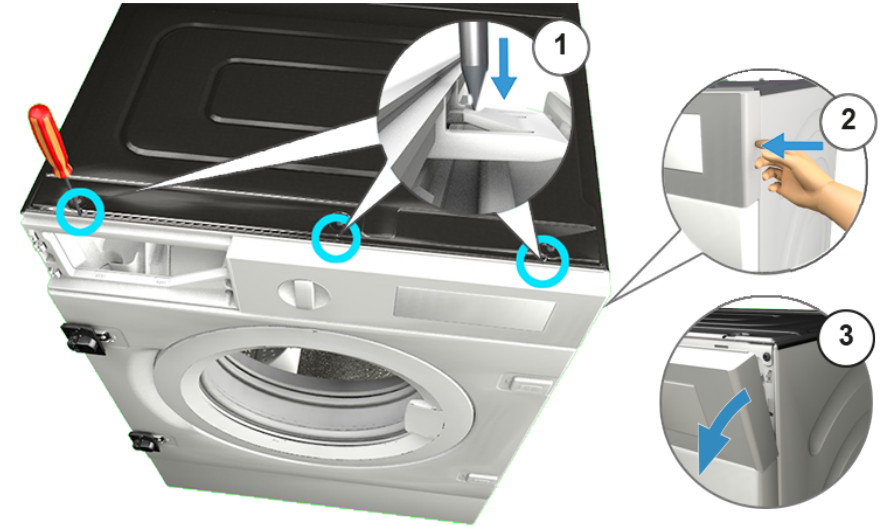

4. Ta bort kontrollpanelen.

4.1.2 Montera kontrollpanel

► Montera i omvänd ordning.

4.2 Byta tvättmedelsfack

Förutsättning:

- ✓ Apparatens är bortkopplad från strömförsörjning.
- ✓ Apparatens är bortkopplad från vattenförsörjning.

4.2.1 Ta bort tvättmedelsfack

1. Dra ut tvättmedelsfacket.
2. 1. Tryck nedåt på insatsen (1).
2. Ta ut tvättmedelsfacket (2).

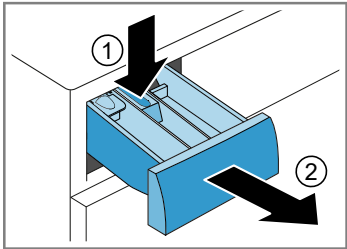

4.2.2 Montera tvättmedelsfack

- ▶ Montera i omvänd ordning.

4.3 Byta handtag till tvättmedelsfack

Förutsättning:

- ✓ Apparaten är bortkopplad från strömförsörjning.
- ✓ Apparaten är bortkopplad från vattenförsörjning.
- ✓ [Tvättmedelsfacket har tagits bort.](#)→471

4.3.1 Ta bort handtag till tvättmedelsfack

1. Lossa fästelementen.

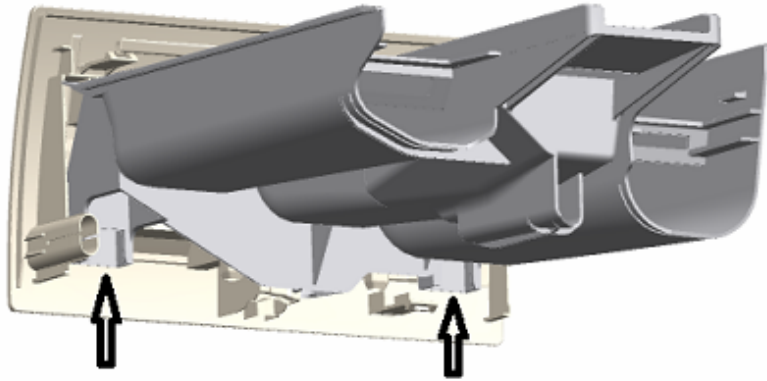

2. Ta bort handtaget till tvättmedelsfacket.

4.3.2 Montera handtag till tvättmedelsfack

- ▶ Montera i omvänd ordning.

4.4 Byta lucka



⚠️ FÖRSIKTIGT!

Öppna gångjärnsdelen!

Risk för att fingrar krossas/fastnar

- ▶ Stick inte in händerna i gångjärnsdelen.
- ▶ Använd skyddshandskar.

Förutsättning:

- ✔ Apparatens är bortkopplad från strömförsörjning.
- ✔ Apparatens är bortkopplad från vattenförsörjning.
- ✔ Luckan är öppen.
- ✔ Skåpfronten har tagits bort.

4.4.1 Ta bort lucka

1.



OBS!

Risk för fallande delar på grund av lossade skruvar!

Materiella skador på andra delar av maskinen eller i kundens hem, t.ex. vid botten.

- ▶ Säkra komponenter så att de inte faller ner.



⚠️ FÖRSIKTIGT!

Risk för fallande delar på grund av lossade skruvar!

Personskador på grund av fallande delar.

- ▶ Säkra komponenter så att de inte faller ner.

Ta bort skruvarna (1).

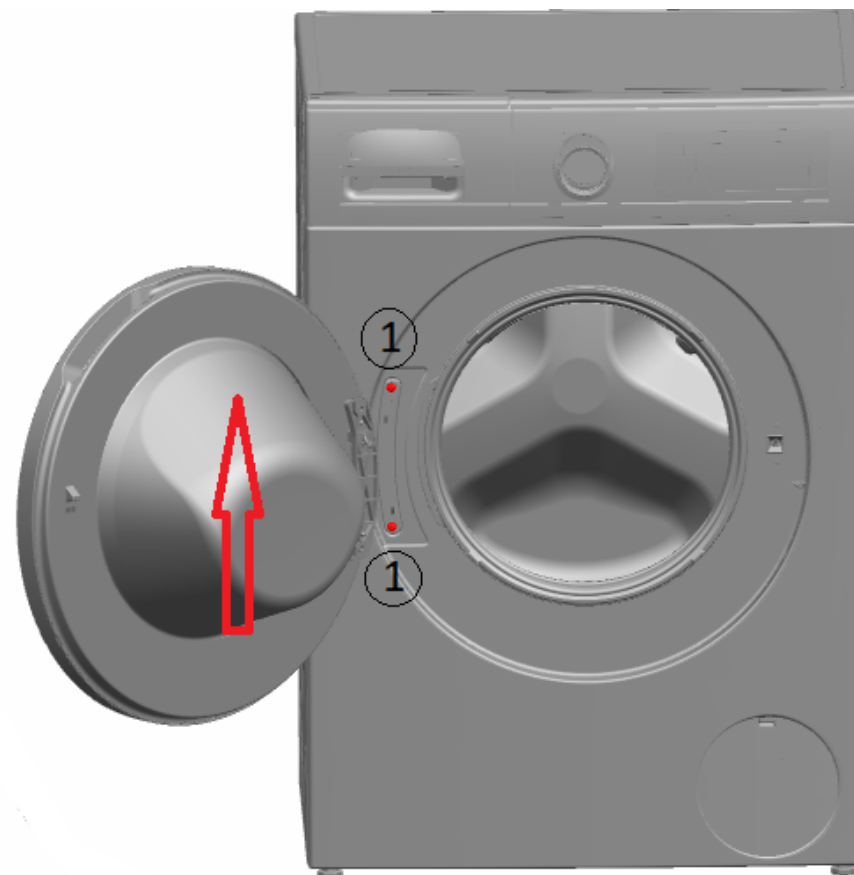

2. Flytta luckan uppåt.

4.4.2 Montera lucka

- ▶ Montera i omvänd ordning.

4.5 Byta luckans komponenter



FÖRSIKTIGT!

Öppna gångjärnsdelen!

Risk för att fingrar krossas/fastnar

- ▶ Stick inte in händerna i gångjärnsdelen.
- ▶ Använd skyddshandskar.

Förutsättning:

- ✓ Apparatens är bortkopplad från strömförsörjning.
- ✓ Apparatens är bortkopplad från vattenförsörjning.
- ✓ Skåpfronten har tagits bort.
- ✓ [Luckan har tagits bort.](#) → 473

4.5.1 Ta bort luckans komponenter

- ▶ Demontera luckan utifrån och in.

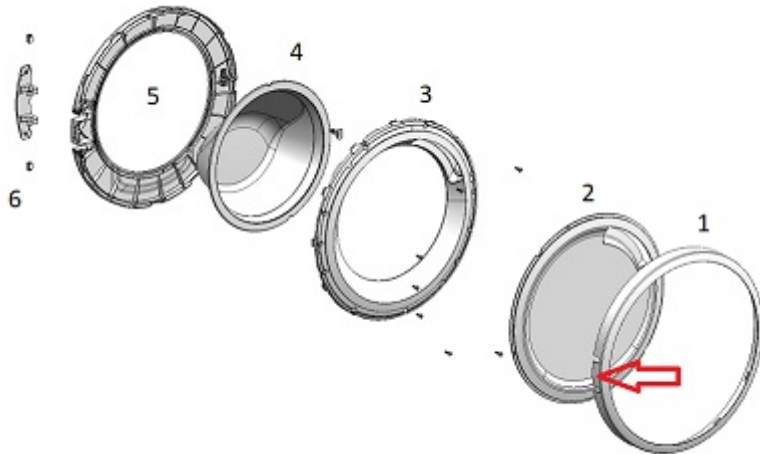

4.5.2 Montera luckans komponenter

- ▶ Montera i omvänd ordning.

4.6 Byta luckans gångjärn



FÖRSIKTIGT!

Öppna gångjärnsdelen!

Risk för att fingrar krossas/fastnar

- ▶ Stick inte in händerna i gångjärnsdelen.
- ▶ Använd skyddshandskar.

Förutsättning:

- ✓ Apparaten är bortkopplad från strömförsörjning.
- ✓ Apparaten är bortkopplad från vattenförsörjning.

4.6.1 Ta bort luckans gångjärn

1. Lossa de två skruvarna.
2. Ta bort luckan.
3. Demontera luckan utifrån och in.

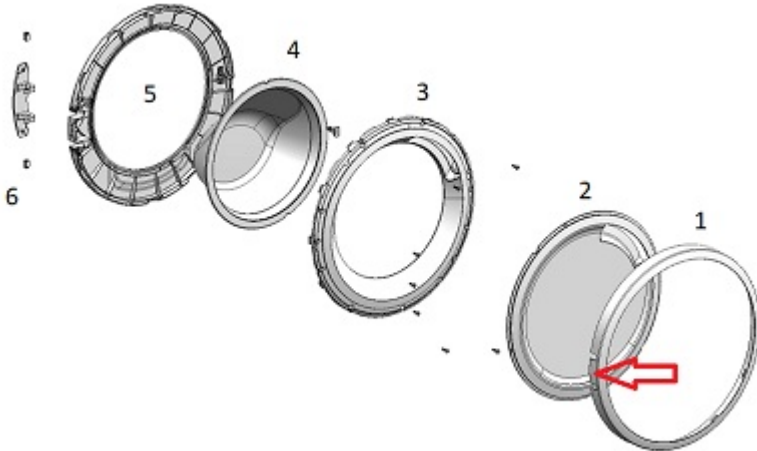

4. Ta bort luckans gångjärn.

4.6.2 Montera luckans gångjärn

- ▶ Montera i omvänd ordning.

4.7 Byta luckans tätning

| | |
|--|--|
|  | FÖRSIKTIGT! Vassa höljeskanter! Skärskador ▶ Använd skyddshandskar. |
|--|--|

| | |
|--|---|
|  | FÖRSIKTIGT! Risk för fallande delar på grund av lossade skruvar! Personskador på grund av fallande delar. ▶ Säkra komponenter så att de inte faller ner. |
|--|---|

| | |
|--|---|
|  | OBS! Risk för fallande delar på grund av lossade skruvar! Materiella skador på andra delar av maskinen eller i kundens hem, t.ex. vid botten. ▶ Säkra komponenter så att de inte faller ner. |
|--|---|

Förutsättning:

- ✓ Apparaten är bortkopplad från strömförsörjning.
- ✓ Apparaten är bortkopplad från vattenförsörjning.
- ✓ Maskinen är fritt åtkomlig.
- ✓ [Tvättmedelsfacket har tagits bort.→471](#)
- ✓ Kontrollpanelen har tagits bort.
- ✓ [Luckan har tagits bort.→473](#)
- ✓ [Bottenhöljet har tagits bort.→481](#)

4.7.1 Ta bort luckans tätning

1. Lossa på hållaren på trumlampan.

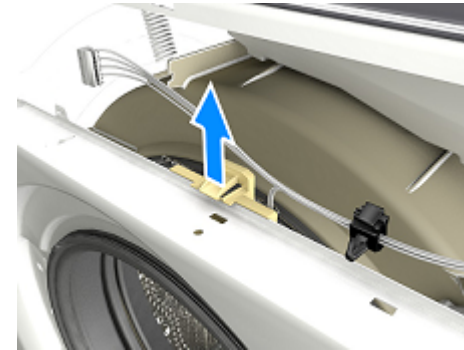

2.

| | |
|---|--|
|  | OBS! Risk för att ytan skadas! Maskinens yta kan repas om fel verktyg används. ▶ Använd bara plastverktyg för att byta ut spänningen. |
|---|--|

Ta bort spänningen från packningen med ett plastverktyg.

3. Lossa luckans tätning från frontpanelen.
4. Lossa kabelkontakten från luckans lås.

Reparation

5. Lossa skruvarna i angiven ordningsföljd.



6. Ta bort frontpanelen.

7. Lossa alla slangkopplingar.

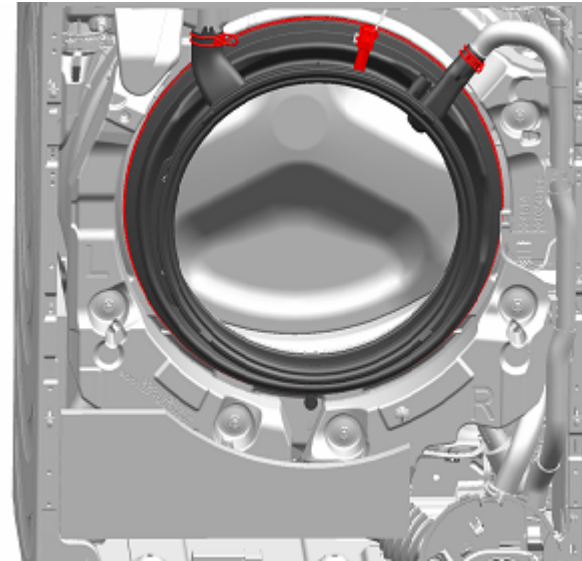

8. Ta bort luckans tätning.

4.7.2 Montera luckans tätning

► Montera i omvänd ordning.

4.8 Byta luckans lås

Som tillverkare är vi ålagda att för våra kunder tillhandahålla reservdelen lucklås inklusive reparationsanvisningar i enlighet med förordning (EU) 2019/2023. Vi vill dock påminna om att det efter byte av luckans lås krävs ett elsäkerhetstest utfört av behörig elektriker innan maskinen tas i bruk igen. Denna person måste vara verifierbart behörig enligt det aktuella landets lagar, bestämmelser och standarder.

| | |
|--|--|
|  | <p>FARA!</p> <p>Risk för elstötar på grund av strömförande delar! Livsfara på grund av elstötar vid felaktiga reparationer</p> <ul style="list-style-type: none">▶ Elektriska delar ska repareras av behörig elektriker.▶ Låt utföra ett säkerhetstest efter reparationen, i enlighet med VDE 0701 eller landsspecifika regler. |
|--|--|

| | |
|--|---|
|  | <p>FÖRSIKTIGT!</p> <p>Vassa höljeskanter! Skärskador</p> <ul style="list-style-type: none">▶ Använd skyddshandskar. |
|--|---|

| | |
|--|--|
|  | <p>VARNING!</p> <p>Lutande maskiner kan glida! Frakturer/krosskador</p> <ul style="list-style-type: none">▶ Säkra maskiner så att de inte kan glida. |
|--|--|

| | |
|---|--|
|  | <p>FÖRSIKTIGT!</p> <p>Risk för fallande delar på grund av lossade skruvar! Personskador på grund av fallande delar.</p> <ul style="list-style-type: none">▶ Säkra komponenter så att de inte faller ner. |
|---|--|

| | |
|--|--|
|  | <p>OBS!</p> <p>Risk för fallande delar på grund av lossade skruvar! Materiella skador på andra delar av maskinen eller i kundens hem, t.ex. vid botten.</p> <ul style="list-style-type: none">▶ Säkra komponenter så att de inte faller ner. |
|--|--|

Förutsättning:

- ✓ Apparaten är bortkopplad från strömförsörjning.
- ✓ Apparaten är bortkopplad från vattenförsörjning.

- ✓ Maskinen är fritt åtkomlig.
- ✓ Skåpfronten har tagits bort.
- ✓ Kontrollpanelen har tagits bort.
- ✓ [Luckan har tagits bort.→473](#)
- ✓ Spännringen har tagits bort.
- ✓ Frontpanelen har tagits bort.
- ✓ Luckans tätning har tagits bort.

4.8.1 Ta bort luckans lås

1. Dra ur kontakten till luckans lås.
2. Lossa luckans lås.



3. Ta bort luckans lås.

4.8.2 Montera luckans lås

Luckans lås måste vara i rätt läge för att maskinens nödöppning av luckan ska fungera.

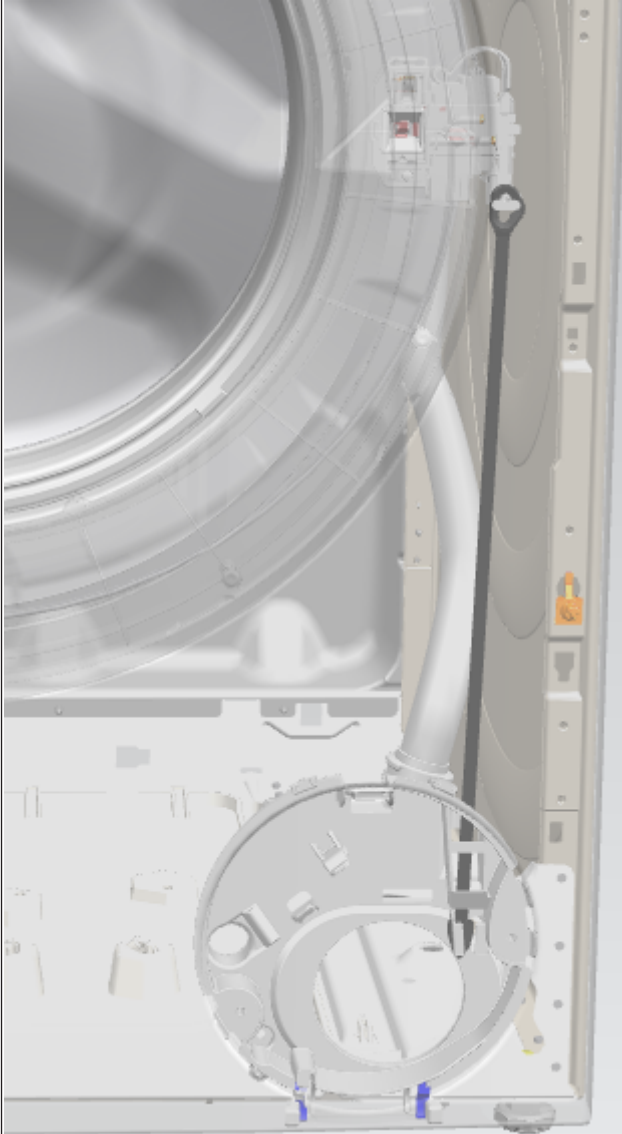

- ▶ Montera i omvänd ordning.

4.9 Byta trummans lampa



⚠️ FÖRSIKTIGT!

Vassa höljeskanter!
Skärskador
▶ Använd skyddshandskar.



⚠️ VARNING!

Lutande maskiner kan glida!
Frakturer/krosskador
▶ Säkra maskiner så att de inte kan glida.



⚠️ FÖRSIKTIGT!

Risk för fallande delar på grund av lossade skruvar!
Personskador på grund av fallande delar.
▶ Säkra komponenter så att de inte faller ner.



OBS!

Risk för fallande delar på grund av lossade skruvar!
Materiella skador på andra delar av maskinen eller i kundens hem, t.ex. vid botten.
▶ Säkra komponenter så att de inte faller ner.

Förutsättning:

- ✓ Apparaten är bortkopplad från strömförsörjning.
- ✓ Apparaten är bortkopplad från vattenförsörjning.
- ✓ Maskinen är fritt åtkomlig.
- ✓ [Tvättmedelsfacket har tagits bort. →471](#)
- ✓ Kontrollpanelen har tagits bort.

4.9.1 Ta bort trummans lampa

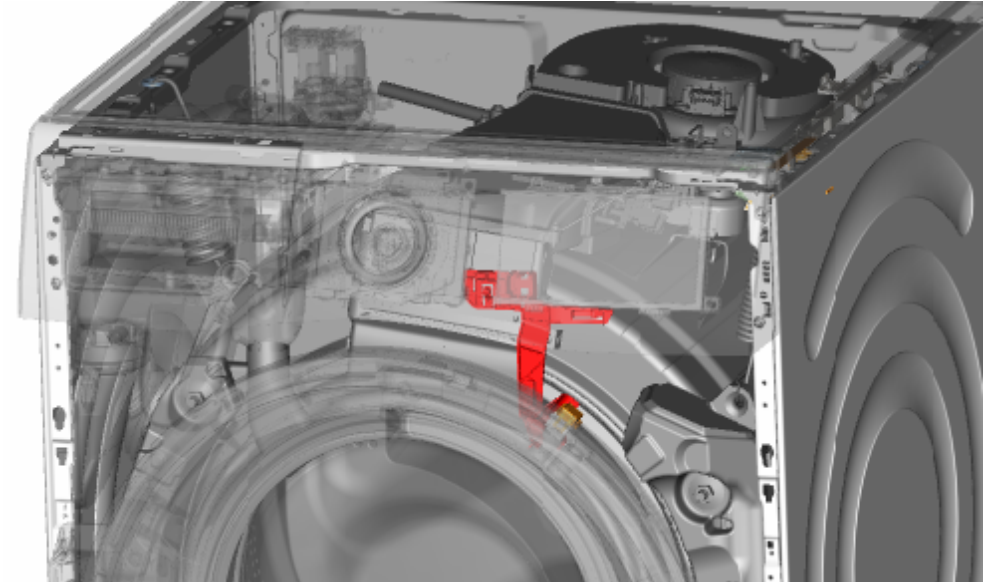

1. Dra ut trummans lampa från maskinen.
2. Lossa elanslutningarna.
3. Ta bort trummans lampa från lamphållaren.

4.9.2 Montera luckans lampa

- ▶ Montera i omvänd ordning.

4.10 Byta bottenhölje



Bild 1: Bottengrupphölje

Förutsättning:

- ✓ Apparaten är bortkopplad från strömförsörjning.
- ✓ Apparaten är bortkopplad från vattenförsörjning.
- ✓ Skåpfronten har tagits bort.

4.10.1 Ta bort bottenhölje

Förutsättning:

- ✓ Apparaten är bortkopplad från strömförsörjning.
- ✓ Apparaten är bortkopplad från vattenförsörjning.

1. Ta bort bottenhöljet.

2. Koppla loss slangen från hållaren.

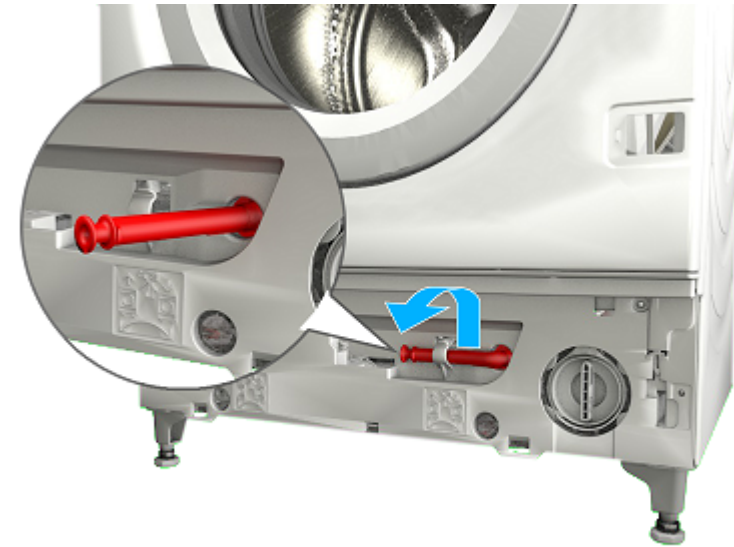

Reparation

3. 1. Skruva loss skruven (1).
2. Tryck på hållpunkten och ta bort den nedåt (2).

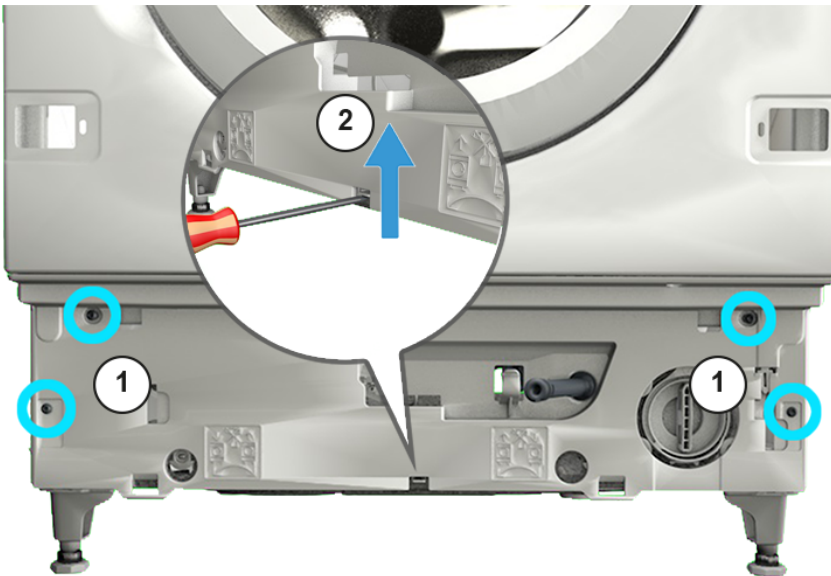

4. Dra i bottengrupphöljet och ta bort det framåt.



5. Dra ut slangen ur höljet.

4.10.2 Montera höljet

- Montera i omvänd ordning.

4.11 Byta frontpanel



FÖRSIKTIGT!

Vassa höljeskanter!
Skärskador

- ▶ Använd skyddshandskar.

Förutsättning:

- ✓ Apparatens är bortkopplad från strömförsörjning.
- ✓ Apparatens är bortkopplad från vattenförsörjning.
- ✓ Maskinen är fritt åtkomlig.
- ✓ [Tvättmedelsfacket har tagits bort. →471](#)
- ✓ Skåpfronten har tagits bort.
- ✓ [Luckan har tagits bort. →473](#)
- ✓ Luckans tätning har tagits bort.

4.11.1 Ta bort frontpanel

1. Lossa på hållaren på trumlampan.

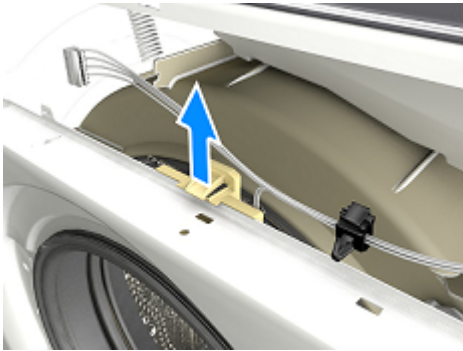

2.



FÖRSIKTIGT!

Risk för fallande delar på grund av lossade skruvar!
Personskador på grund av fallande delar.

- ▶ Säkra komponenter så att de inte faller ner.



OBS!

Risk för fallande delar på grund av lossade skruvar!
Materiella skador på andra delar av maskinen eller i kundens hem, t.ex. vid botten.

- ▶ Säkra komponenter så att de inte faller ner.

Lossa skruvarna i angiven ordningsföljd.



3. Ta bort frontpanelen.

4.11.2 Montera frontpanel

▶ Montera i omvänd ordning.

Onarım İpuçları - Çamaşır makinesi

| | |
|---|------------|
|  Bu doküman hakkında | 486 |
| 1.1 Önemli bilgi | 486 |
| 1.1.1 Amacı | 486 |
| 1.2 Sembollerinin açıklaması | 486 |
| 1.2.1 Tehlike kademeleri | 486 |
| 1.2.2 Tehlike sembolleri | 486 |
| 1.2.3 İkaz bilgilerinin yapısı | 487 |
| 1.2.4 Genel semboller | 487 |
|  Güvenlik | 488 |
| 2.1 Genel Güvenlik bilgileri | 488 |
| 2.1.1 Tüm ev gereçleri | 488 |
|  Ekipman ve yardım | 489 |
|  Onarım | 490 |
| 4.1 Gösterge panelinin değiştirilmesi | 490 |
| 4.1.1 Gösterge panelinin sökülmesi | 490 |
| 4.1.2 Gösterge panelinin takılması | 491 |
| 4.2 Deterjan bölmesinin değiştirilmesi | 492 |
| 4.2.1 Deterjan bölmesinin sökülmesi | 492 |
| 4.2.2 Deterjan bölmesinin takılması | 492 |
| 4.3 Deterjan bölmesi tutamağının değiştirilmesi | 493 |
| 4.3.1 Deterjan bölmesi tutamağının sökülmesi | 493 |
| 4.3.2 Deterjan bölmesi tutamağının takılması | 493 |
| 4.4 Kapının değiştirilmesi | 494 |
| 4.4.1 Kapının sökülmesi | 494 |
| 4.4.2 Kapının takılması | 494 |
| 4.5 Kapı bileşenlerinin değiştirilmesi | 495 |
| 4.5.1 Kapı bileşenlerinin sökülmesi | 495 |
| 4.5.2 Kapı bileşenlerinin takılması | 495 |
| 4.6 Kapı menteşesinin değiştirilmesi | 496 |
| 4.6.1 Kapı menteşesinin sökülmesi | 496 |
| 4.6.2 Kapı menteşesinin takılması | 496 |
| 4.7 Kapı contasının değiştirilmesi | 497 |
| 4.7.1 Kapı contasının sökülmesi | 497 |
| 4.7.2 Kapı contasının takılması | 498 |

| | |
|--|-----|
| 4.8 Kapı kilidinin değiştirilmesi | 499 |
| 4.8.1 Kapı kilidinin sökülmesi | 499 |
| 4.8.2 Kapı kilidinin monte edilmesi | 500 |
| 4.9 Tambur lambasının değiştirilmesi | 501 |
| 4.9.1 Tambur lambasının sökülmesi | 501 |
| 4.9.2 Tambur lambasının takılması | 501 |
| 4.10 Alt kapağın değiştirilmesi | 502 |
| 4.10.1 Alt kapağın sökülmesi | 502 |
| 4.10.2 Kapağın takılması | 503 |
| 4.11 Ön panelin değişimi | 504 |
| 4.11.1 Ön panelin sökülmesi | 504 |
| 4.11.2 Ön sacın takılması | 505 |

i Bu doküman hakkında

1.1 Önemli bilgi

1.1.1 Amacı

Bu onarım ipuçları, tüketicinin cihazları, geçerli eko-tasarım yönetmeliğine göre (03/2021 itibarıyla) kendi başına onarması için destek sunar.

İpuçları, ilgili uyarı ve riskler de dahil olmak üzere tanımlanmış yedek parçaların nasıl değiştirilmesi gerektiğine dair bilgiler içerir.

Sorularınız varsa, lütfen müşteri hizmetlerimizle irtibata geçin. Yalnızca onarım ipuçlarına gerektiği gibi uyulduğu takdirde hasarlar için sorumluluk üstleniriz.

1.2 Sembollerinin açıklaması

1.2.1 Tehlike kademeleri

Tehlike kademeleri bir sembolden ve bir sinyal kelimesinden oluşur. Sinyal kelimesi tehlikenin şiddetini ve önemini tanımlar.





| Tehlike kademesi | Anlamı |
|--|--|
|  TEHLİKE | İkaz bilgisinin dikkate alınmaması ölüme veya ağır yaralanmalara sebep olur. |
|  UYARI | İkaz bilgisinin dikkate alınmaması ölüme veya ağır yaralanmalara sebep olabilir. |
|  DİKKAT | İkaz bilgisinin dikkate alınmaması hafif yaralanmalara sebep olabilir. |
| DİKKATI | İkaz bilgisinin dikkate alınmaması maddi hasarların oluşmasına sebep olabilir. |

Tablo 1: Tehlike kademeleri



1.2.2 Tehlike sembolleri

Tehlike sembolleri, tehlike türü hakkında bilgi veren anlamlı resimsel gösterimlerdir.

Bu dokümanda aşağıdaki tehlike sembolleri kullanılmıştır:

| Tehlike sembolü | Anlamı |
|---|--|
|  | Genel ikaz bilgisi |
|  | Elektrik geriliminden kaynaklanan tehlike |
|  | Patlamadan kaynaklanan tehlike |
|  | Kesmeden dolayı yaralanma tehlikesi |
|  | Sıkışıp ezilmeden dolayı yaralanma tehlikesi |

i Bu doküman hakkında

| Tehlike sembolü | Anlamı |
|--|--|
|  | Sıcak yüzeylerden kaynaklanan tehlike |
|  | Güçlü elektromanyetik alan tehlikesi |
|  | İyonizasyon olmayan ışınlardan kaynaklanan tehlike |

Tablo 2: Tehlike sembolleri

1.2.3 İkaz bilgilerinin yapısı

Bu dokümandaki ikaz bilgilerinin standart olarak görünüşü ve yapısı aynıdır.



| | |
|--|--|
|  | ⚠ TEHLİKE Tehlikenin türü ve kaynağı!! Tehlike / ikaz bilgisinin dikkate alınmamasının sonucu. ► Tehlikeye karşı korunmak için yapılacak işlem ve yasaklar. |
|--|--|







Aşağıdaki örnekte, gerilim ileten parçalar nedeniyle oluşabilecek elektrik çarpması tehlikesi hakkında uyarıda bulunan bir ikaz bilgisi gösterilmiştir. Tehlikeyi önlemek için alınması gereken önlemler belirtilmiştir.

| | |
|--|---|
|  | ⚠ TEHLİKE Gerilim ileten parçalar nedeniyle elektrik çarpması tehlikesi!! Elektrik çarpması sebebiyle ölüm ► Onarıma başlamadan önce cihazın elektrik şebeke bağlantısını en az 60 saniye süreyle sökün. |
|--|---|

1.2.4 Genel semboller

Bu dokümanda aşağıdaki genel semboller kullanılmıştır:

| Genel sembol | Anlamı |
|--|---|
|  | Özel ipucu işareti (metin ve/veya grafik) |
|  | Basit ipucu işareti (yalnızca metin) |
|  | Video linki işareti |

| Genel sembol | Anlamı |
|---|---|
|  | Gerekli araçlar işareti |
|  | Ön koşulların işareti |
|  | Koşul işareti (... olursa olur) |
|  | Sonuç işareti |
|  | Tuş veya düğme işareti |
|  | Malzeme numarası işareti |
|  | Gösterilen yazı / ekran işareti (cihaz ekranındaki) |

Tablo 3: Genel semboller

2.1 Genel Güvenlik bilgileri

2.1.1 Tüm ev gereçleri

Gerilim ileten parçalar nedeniyle elektrik çarpması tehlikesi!

- Elektrikli bileşenlerde yapılan onarımlarda hatalar, elektrik çarpmasına neden olabilir!
- Cihaz çalışmalara başlamadan en az 60 saniye önce elektrik şebekesinden ayrılmalıdır.
- Onarım sonrasında VDE 0701 veya ülkeye özel düzenlemeler uyarınca bir güvenlik testi gerçekleştirilmelidir.

Keskin kenarlar nedeniyle yaralanma tehlikesi!

- Koruyucu eldiven kullanılmalıdır.

Ağır ve hareketli parçaların onarım, bakım, hata arama ve servis işlemlerinde yaratabileceği ezilme riskleri

- Koruyucu ayakkabı giyin.
- Yere düşmemesi için ağır parçaları emniyete alın.
- Hareketli parçaların arasına gövde parçaları koymayın.





Cihaz güvenliğinde / fonksiyonda tehlike!

- Yalnızca orijinal parçalar kullanılmalıdır.

Elektrostatik hassasiyeti olan bileşenlerde hasar tehlikesi (ESD)!





- Bağlantılar ve iletken yolları da dahil olmak üzere modüllere dokunmayın.

Ekipman ve yardım

| Tanımlama | Detaylar | Görüntüler |
|--|--|--|
| Sabitleme parçası [15000155] | Plastik parçaların gevşetilmesi için alet |  |
| Delik boşluklu Torx T20 tornavida [00340764] | 100 mm, emniyet pimli vidalar için |  |
| Tork anahtarı [15000441] | Tork anahtarı 20 - 100 Nm | |
| Düz tornavida [00340854] | Bıçak 3,5 mm x 0,6 mm x 100 mm, Koruyucu İzolasyon 1000 V AC |  |
| Düz tornavida [00340855] | Bıçak 5,5 mm x 1,0 mm x 125 mm, Koruyucu İzolasyon 1000 V AC |  |
| Kargaburun pense, açılı ağızlı [00341269] | Uzunluk 200 mm |  |
| Yan keski [00342182] | Uzunluk: 200 mm |  |

| Tanımlama | Detaylar | Görüntüler |
|-------------------------------|---------------------------|---|
| Kombine Anahtar [00340811] | Anahtar boyutu 10°mm, M6 |  |
| Combination wrench [00340814] | Anahtar boyutu 13°mm, M8 |  |
| Kombine Anahtar [00340817] | Anahtar boyutu 17 mm, M10 |  |
| Kombine Anahtar [15000459] | Anahtar boyutu 16°mm, M10 |  |

4.1 Gösterge panelinin değiştirilmesi

| | |
|--|--|
|  | <p>⚠ DİKKAT</p> <p>Keskin gövde kenarları! Kesik yaralanmaları ▶ Koruyucu eldiven kullanılmalıdır.</p> |
|  | <p>⚠ UYARI</p> <p>Eğilmiş cihazların kayması! Kemik kırılmaları / çarpma sonucu yaralanmalar ▶ Cihazları kaymaya karşı emniyete alın.</p> |
|  | <p>⚠ DİKKAT</p> <p>Vidaların gevşetilmesi nedeniyle parçaların düşme tehlikesi! Düşen parçalar nedeniyle yaralanma. ▶ Bileşenleri düşmeye karşı emniyete alın.</p> |
|  | <p>DİKKAT!</p> <p>Vidaların gevşetilmesi nedeniyle parçaların düşme tehlikesi! Cihazın diğer parçalarında veya müşterinin evinde (örn. zemin) hasarlar. ▶ Bileşenleri düşmeye karşı emniyete alın.</p> |

Ön koşul:

- ✓ Cihazın fişi çekilir.
- ✓ Cihaz, su beslemesinden ayrılır.
- ✓ Cihaza serbest erişim mümkün.
- ✓ [Deterjan bölmesi söküldü.→492](#)

4.1.1 Gösterge panelinin sökülmesi

1. Tırnağı serbest bırakın (1).
2. Kapağı sökün (2).

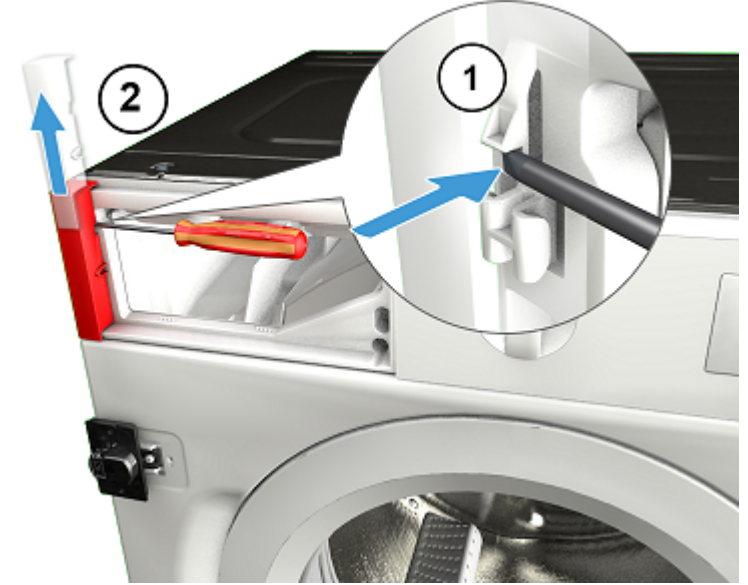

2. Vidaları sökün.



3. 1. Tırnakları serbest bırakın (1, 2).
2. Gösterge panelini öne doğru çekin (3).

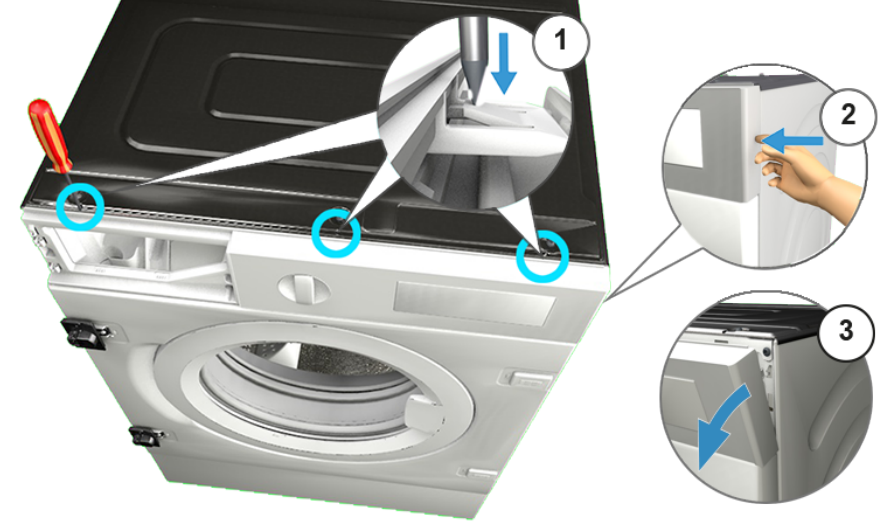

4. Gösterge panelini sökün.

4.1.2 Gösterge panelinin takılması

► Ters sıra ile monte edin.

4.2 Deterjan bölmesinin değiştirilmesi

Ön koşul:

- ✓ Cihazın fişi çekilir.
- ✓ Cihaz, su beslemesinden ayrılır.

4.2.1 Deterjan bölmesinin sökülmesi

1. Deterjan bölmesini dışarı çekin.
2. 1. Ek parçanın üzerine bastırın (1).
2. Deterjan bölmesini sökün (2).

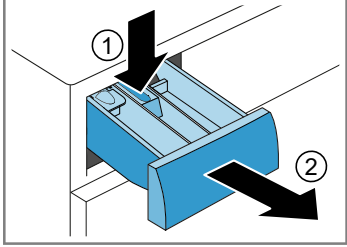

4.2.2 Deterjan bölmesinin takılması

- ▶ Ters sıra ile monte edin.

4.3 Deterjan bölmesi tutamağının değiştirilmesi

Ön koşul:

- ✓ Cihazın fişi çekilir.
- ✓ Cihaz, su beslemesinden ayrılır.
- ✓ [Deterjan bölmesi sökülüdü.→492](#)

4.3.1 Deterjan bölmesi tutamağının sökülmesi

1. Tırnakları serbest bırakın.

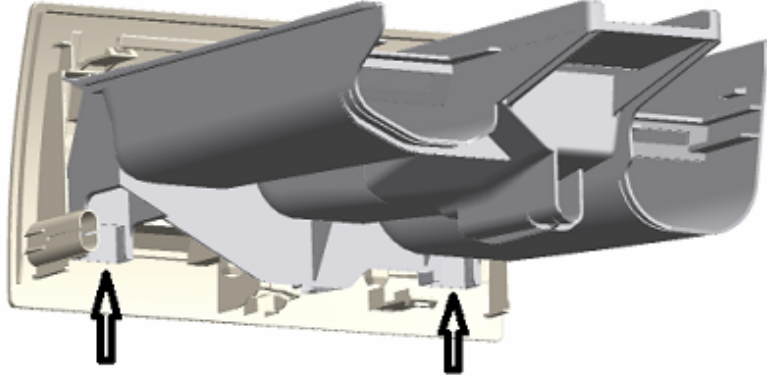

2. Deterjan bölmesi tutamağını sökün.

4.3.2 Deterjan bölmesi tutamağının takılması

- ▶ Ters sıra ile monte edin.

4.4 Kapının değiştirilmesi

| | |
|--|---|
|  | ⚠ DİKKAT Açık menteşe bölgesi! Parmakların ezilmesi / sıkışması ▶ Menteşe bölgesine elinizi sokmayın. ▶ Koruyucu eldiven kullanılmalıdır. |
|--|---|

Ön koşul:

- ✔ Cihazın fişi çekilir.
- ✔ Cihaz, su beslemesinden ayrılır.
- ✔ Kapı açık.
- ✔ Mobilya paneli söküldü.

4.4.1 Kapının sökülmesi

1.

| | |
|---|---|
|  | DİKKAT! Vidaların gevşetilmesi nedeniyle parçaların düşme tehlikesi! Cihazın diğer parçalarında veya müşterinin evinde (örn. zemin) hasarlar. ▶ Bileşenleri düşmeye karşı emniyete alın. |
|---|---|

| | |
|--|---|
|  | ⚠ DİKKAT Vidaların gevşetilmesi nedeniyle parçaların düşme tehlikesi! Düşen parçalar nedeniyle yaralanma. ▶ Bileşenleri düşmeye karşı emniyete alın. |
|--|---|

Vidaları sökün (1).

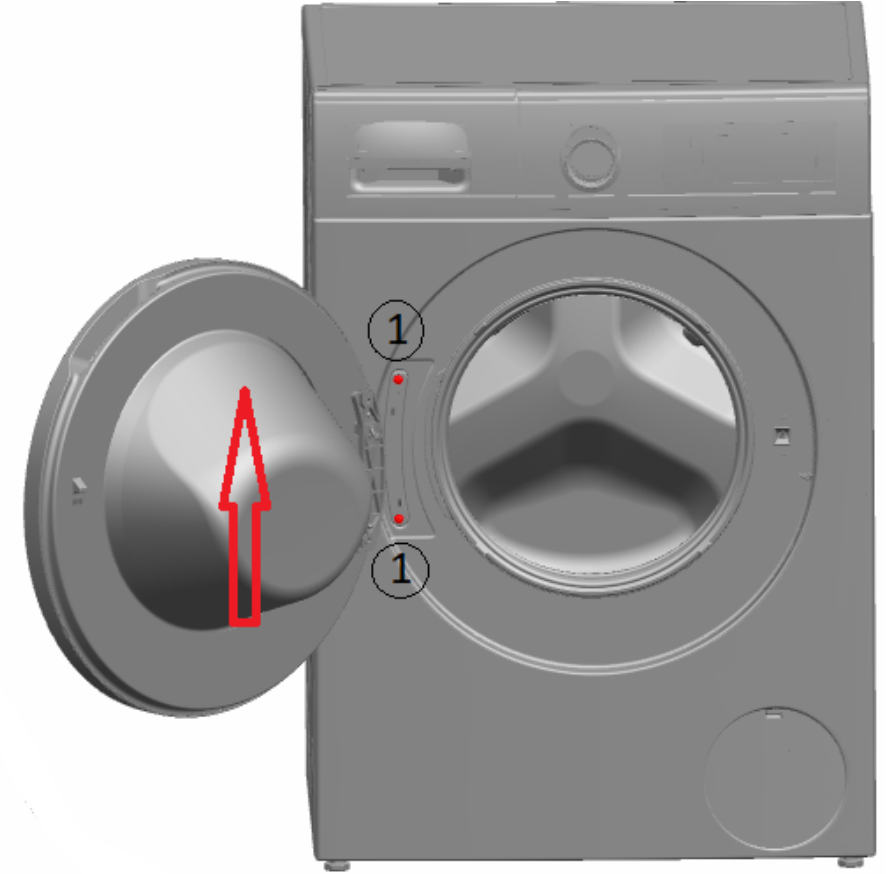

2. Kapıyı yukarıya doğru sökün.

4.4.2 Kapının takılması

- ▶ Ters sıra ile monte edin.

4.5 Kapı bileşenlerinin değiştirilmesi



DİKKAT

Açık menteşe bölgesi!

Parmakların ezilmesi / sıkışması

- ▶ Menteşe bölgesine elinizi sokmayın.
- ▶ Koruyucu eldiven kullanılmalıdır.

Ön koşul:

- ✓ Cihazın fişi çekilir.
- ✓ Cihaz, su beslemesinden ayrılır.
- ✓ Mobilya paneli söküldü.
- ✓ [Kapı kaldırıldı.→494](#)

4.5.1 Kapı bileşenlerinin sökülmesi

- ▶ Kapıyı dıştan içe sökün.

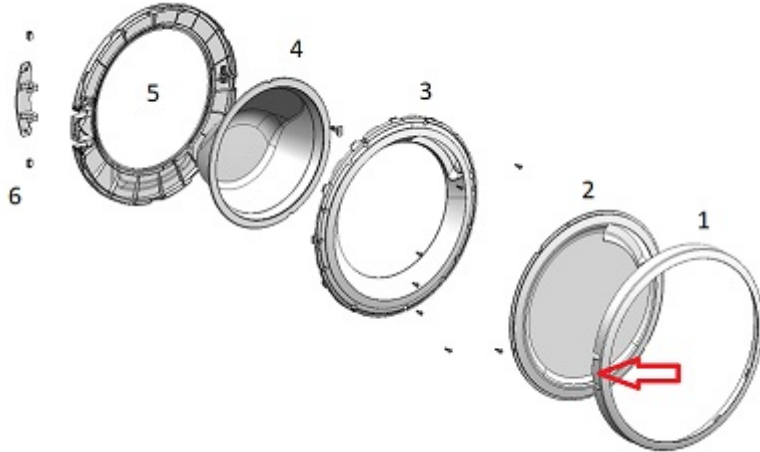

4.5.2 Kapı bileşenlerinin takılması

- ▶ Ters sıra ile monte edin.

4.6 Kapı menteşesinin değiştirilmesi



DİKKAT

Açık menteşe bölgesi!

Parmakların ezilmesi / sıkışması

- ▶ Menteşe bölgesine elinizi sokmayın.
- ▶ Koruyucu eldiven kullanılmalıdır.

Ön koşul:

- ✔ Cihazın fişi çekilir.
- ✔ Cihaz, su beslemesinden ayrılır.

4.6.1 Kapı menteşesinin sökülmesi

1. İki vidayı gevşetin.
2. Kapıyı sökün.
3. Kapıyı dıştan içe sökün.

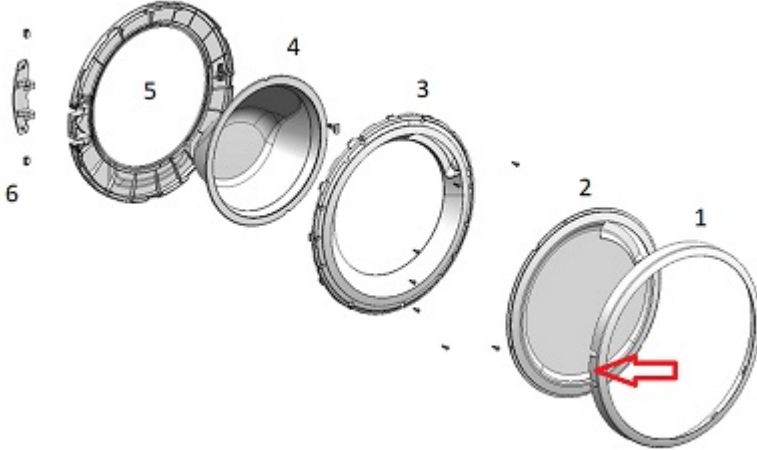



4. Kapı menteşesini sökün.

4.6.2 Kapı menteşesinin takılması

- ▶ Ters sıra ile monte edin.

4.7 Kapı contasının değiştirilmesi

| | |
|--|---|
|  | ⚠ DİKKAT Keskin gövde kenarları! Kesik yaralanmaları ▶ Koruyucu eldiven kullanılmalıdır. |
|--|---|

| | |
|--|---|
|  | ⚠ DİKKAT Vidaların gevşetilmesi nedeniyle parçaların düşme tehlikesi! Düşen parçalar nedeniyle yaralanma. ▶ Bileşenleri düşmeye karşı emniyete alın. |
|--|---|

| | |
|--|---|
|  | DİKKAT! Vidaların gevşetilmesi nedeniyle parçaların düşme tehlikesi! Cihazın diğer parçalarında veya müşterinin evinde (örn. zemin) hasarlar. ▶ Bileşenleri düşmeye karşı emniyete alın. |
|--|---|

Ön koşul:

- ✓ Cihazın fişi çekilir.
- ✓ Cihaz, su beslemesinden ayrılır.
- ✓ Cihaza serbest erişim mümkün.
- ✓ [Deterjan bölmesi söküldü.→492](#)
- ✓ Gösterge paneli söküldü.
- ✓ [Kapı kaldırıldı.→494](#)
- ✓ [Alt kapak söküldü.→502](#)

4.7.1 Kapı contasının sökülmesi

1. Tambur lambasındaki tespit elemanını gevşetin.



2.

| | |
|---|--|
|  | DİKKAT! Yüzeyin hasar görme tehlikesi! Yanlış aletlerin kullanılması sonucu cihazın yüzeyi çizilebilir. ▶ Gergi halkasını değiştirmek için sadece plastik aletler kullanın. |
|---|--|

Gergi halkasını plastik bir aletle contadan sökün.

3. Kapı contasını ön panelden çıkartın.
4. Kablo konektörünü kapı kilidinden çıkartın.

5. Vidaları belirtilen sırada gevşetin.



6. Ön paneli sökünüz.

7. Tüm hortum bağlantılarını ayırın.

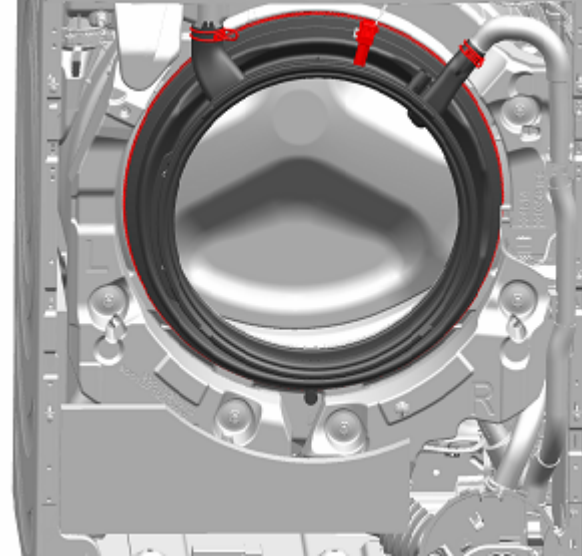

8. Kapı contasını sökün.

4.7.2 Kapı contasının takılması

- Ters sıra ile monte edin.

4.8 Kapı kilidinin değiştirilmesi

(AB) 2019/2023 Düzenlemesi uyarınca, tüketicilere onarım talimatları ile birlikte yedek bir kapı kilidinin sağlanması üretici olarak bizim yükümlülüğümüzdür. Bununla birlikte, bir kapı kilidi değişimi sonrasında cihaz çalıştırılmadan önce kalifiye bir elektrik uzmanı tarafından mutlaka bir elektroteknik güvenlik testinin gerçekleştirilmesi gerektiğini de vurgulamak isteriz. Bu kişinin ülkeye özgü yasalar, düzenlemeler ve standartlar kapsamındaki hükümlerin gerektirdiği niteliklere sahip olduğu doğrulanabilir olmalıdır.

| | |
|--|--|
|  | ⚠ TEHLİKE Gerilim ileten parçalar nedeniyle elektrik çarpması tehlikesi!! Onarımın düzgün yapılması nedeniyle elektrik çarpması sonucu hayati tehlike <ul style="list-style-type: none">▶ Elektrikli parçaların onarımı kalifiye bir elektrik uzmanı tarafından gerçekleştirilmelidir.▶ Onarım sonrasında VDE 0701 veya ülkeye özel düzenlemeler uyarınca bir güvenlik testi gerçekleştirilmelidir. |
|--|--|

| | |
|--|--|
|  | ⚠ DİKKAT Keskin gövde kenarları! Kesik yaralanmaları <ul style="list-style-type: none">▶ Koruyucu eldiven kullanılmalıdır. |
|--|--|

| | |
|---|---|
|  | ⚠ UYARI Eğilmiş cihazların kayması! Kemik kırılmaları / çarpma sonucu yaralanmalar <ul style="list-style-type: none">▶ Cihazları kaymaya karşı emniyete alın. |
|---|---|

| | |
|--|--|
|  | ⚠ DİKKAT Vidaların gevşetilmesi nedeniyle parçaların düşme tehlikesi! Düşen parçalar nedeniyle yaralanma. <ul style="list-style-type: none">▶ Bileşenleri düşmeye karşı emniyete alın. |
|--|--|

| | |
|--|--|
|  | DİKKAT! Vidaların gevşetilmesi nedeniyle parçaların düşme tehlikesi! Cihazın diğer parçalarında veya müşterinin evinde (örn. zemin) hasarlar. <ul style="list-style-type: none">▶ Bileşenleri düşmeye karşı emniyete alın. |
|--|--|

Ön kopul:

- ✓ Cihazın fişi çekilir.

- ✓ Cihaz, su beslemesinden ayrılır.
- ✓ Cihaza serbest erişim mümkün.
- ✓ Mobilya paneli söküldü.
- ✓ Gösterge paneli söküldü.
- ✓ [Kapı kaldırıldı. →494](#)
- ✓ Geri halkası söküldü.
- ✓ Ön saç sökülmüş olmalı.
- ✓ Kapı contası söküldü.

4.8.1 Kapı kilidinin sökülmesi

1. Kapı kilidi fişini ayırın.
2. Kapı kilidini serbest bırakın.



3. Kapı kilidini sökün.

4.8.2 Kapı kilidinin monte edilmesi

Cihazın acil durum kapısının açılma işlevinin sağlanması için kapı kilidi sağ konumda olmalıdır.

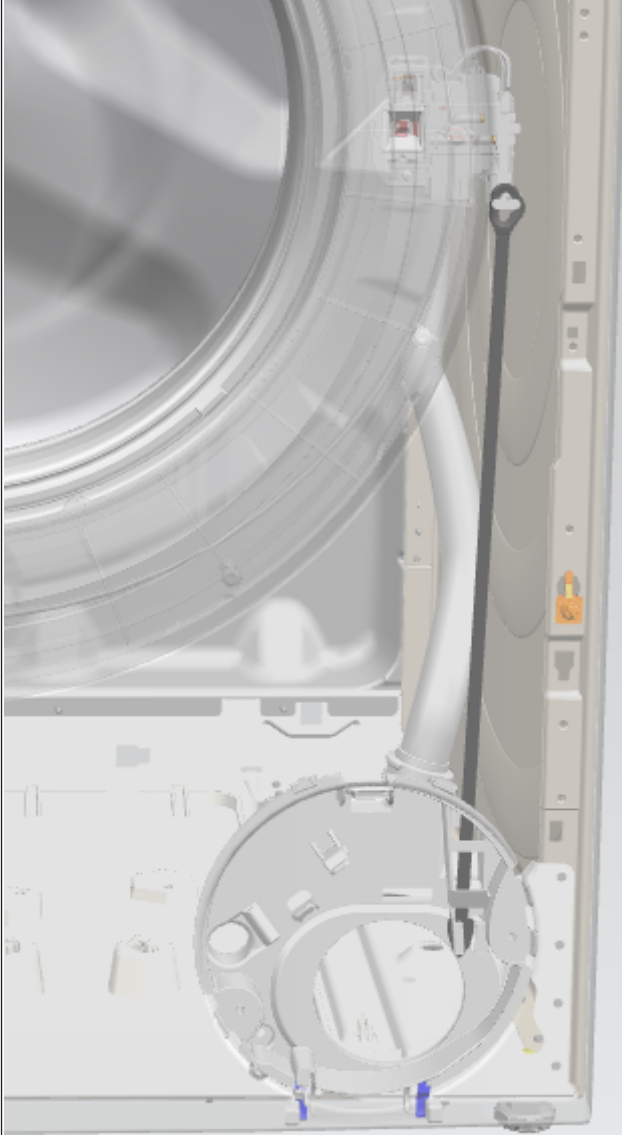

- Ters sıra ile monte edin.

4.9 Tambur lambasının deęiřtirilmesi



DİKKAT

Keskin gövde kenarları!

Kesik yaralanmaları

- Koruyucu eldiven kullanılmalıdır.



UYARI

Eęilmiş cihazların kayması!

Kemik kırılmaları / çarpma sonucu yaralanmalar

- Cihazları kaymaya karşı emniyete alın.



DİKKAT

Vidaların gevşetilmesi nedeniyle parçaların düşme tehlikesi!

Düşen parçalar nedeniyle yaralanma.

- Bileşenleri düşmeye karşı emniyete alın.



DİKKAT!

Vidaların gevşetilmesi nedeniyle parçaların düşme tehlikesi!

Cihazın diğer parçalarında veya müşterinin evinde (örn. zemin) hasarlar.

- Bileşenleri düşmeye karşı emniyete alın.

Ön koşul:

- ✓ Cihazın fiři çekilir.
- ✓ Cihaz, su beslemesinden ayrılır.
- ✓ Cihaza serbest erişim mümkün.
- ✓ [Deterjan bölmesi söküldü.→492](#)
- ✓ Gösterge paneli söküldü.

4.9.1 Tambur lambasının sökülmesi

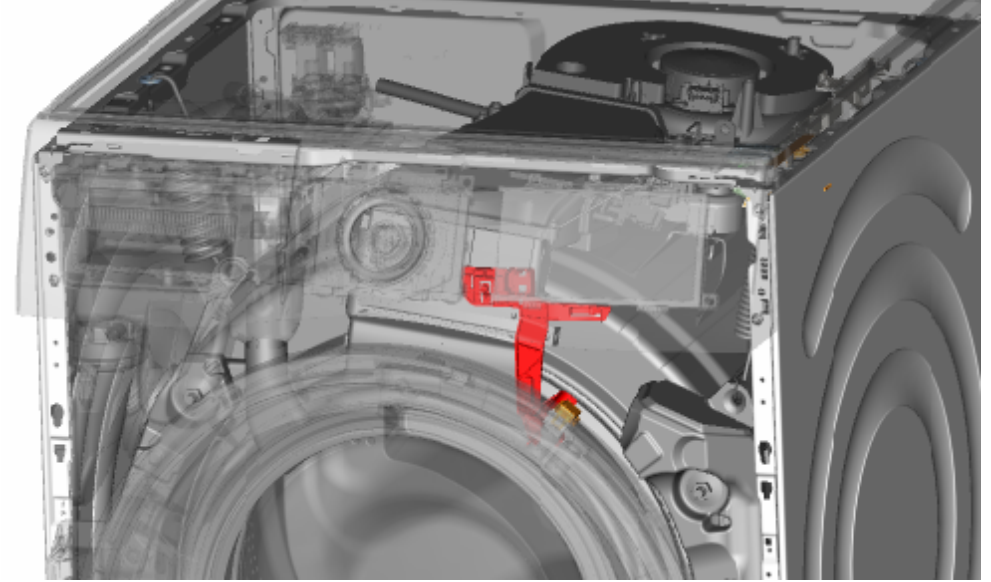

1. Tambur lambası tutucusunu cihazdan dışarı çekin.
2. Elektrik bağlantısını sökün.
3. Tambur lambasını tambur lambası tutucusundan sökün.

4.9.2 Tambur lambasının takılması

- Ters sıra ile monte edin.

4.10 Alt kapağın değiştirilmesi



Resim 1: Alt grup kapağı

Ön koşul:

- ✓ Cihazın fişi çekilir.
- ✓ Cihaz, su beslemesinden ayrılır.
- ✓ Mobilya paneli söküldü.

4.10.1 Alt kapağın sökülmesi

Ön koşul:

- ✓ Cihazın fişi çekilir.
- ✓ Cihaz, su beslemesinden ayrılır.

1. Alt kapağı sökün.

2. Hortumu tutucudan ayırın.

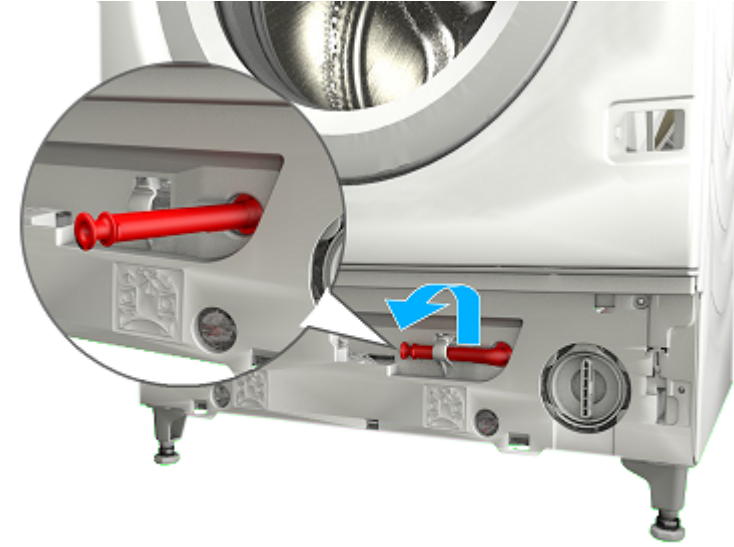

3. 1. Vidayı sökün (1).
2. Tespit noktasına basın ve aşağıya doğru çıkartın (2).

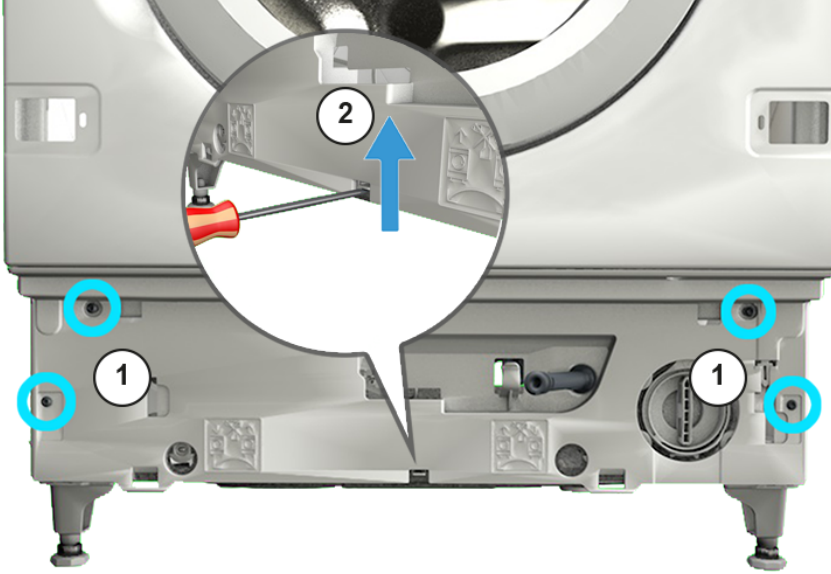

4. Alt grup kapağını çekin ve öne doğru sökün.

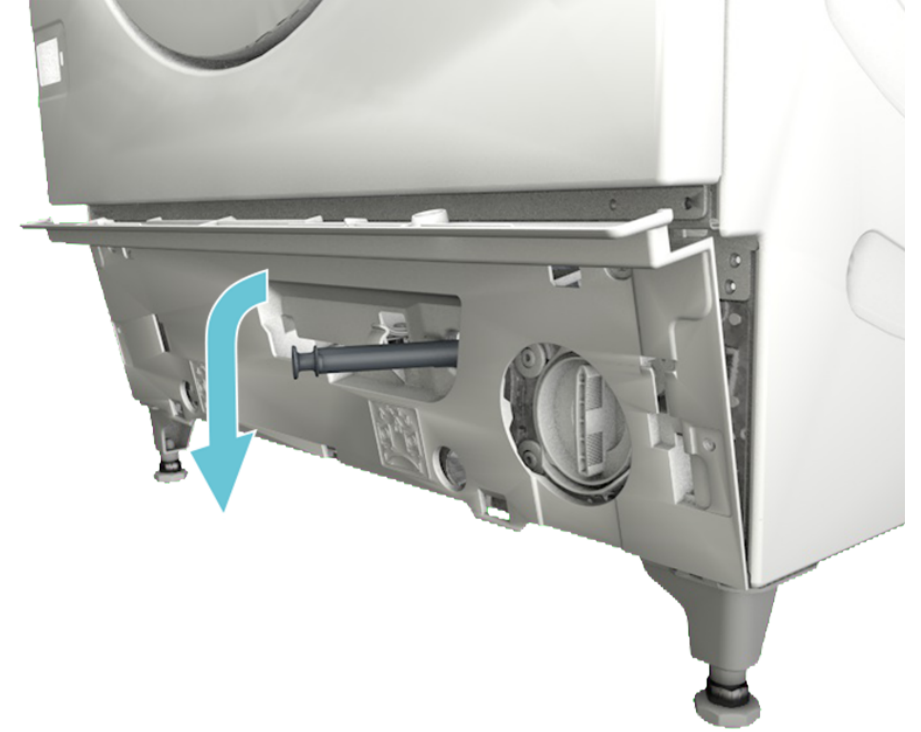

5. Hortumu kapaktan dışarı çekin.

4.10.2 Kapağın takılması

- Ters sıra ile monte edin.

4.11 Ön panelin değişimi



⚠ DİKKAT

Keskin gövde kenarları!

Kesik yaralanmaları

- Koruyucu eldiven kullanılmalıdır.

Ön kopul:

- ✓ Cihazın fişi çekilir.
- ✓ Cihaz, su beslemesinden ayrılır.
- ✓ Cihaza serbest erişim mümkün.
- ✓ [Deterjan bölmesi söküldü. →492](#)
- ✓ Mobilya paneli söküldü.
- ✓ [Kapı kaldırıldı. →494](#)
- ✓ Kapı contası söküldü.

4.11.1 Ön panelin sökülmesi

1. Tambur lambasındaki tespit elemanını gevşetin.

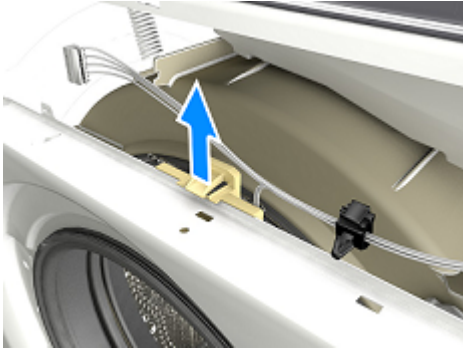

- 2.



⚠ DİKKAT

Vidaların gevşetilmesi nedeniyle parçaların düşme tehlikesi!

Düşen parçalar nedeniyle yaralanma.

- Bileşenleri düşmeye karşı emniyete alın.



DİKKAT!

Vidaların gevşetilmesi nedeniyle parçaların düşme tehlikesi!

Cihazın diğer parçalarında veya müşterinin evinde (örn. zemin) hasarlar.

- Bileşenleri düşmeye karşı emniyete alın.

Vidaları belirtilen sırada gevşetin.



3. Ön paneli sökünüz.

4.11.2 Ön sacın takılması

► Ters sıra ile monte edin.